

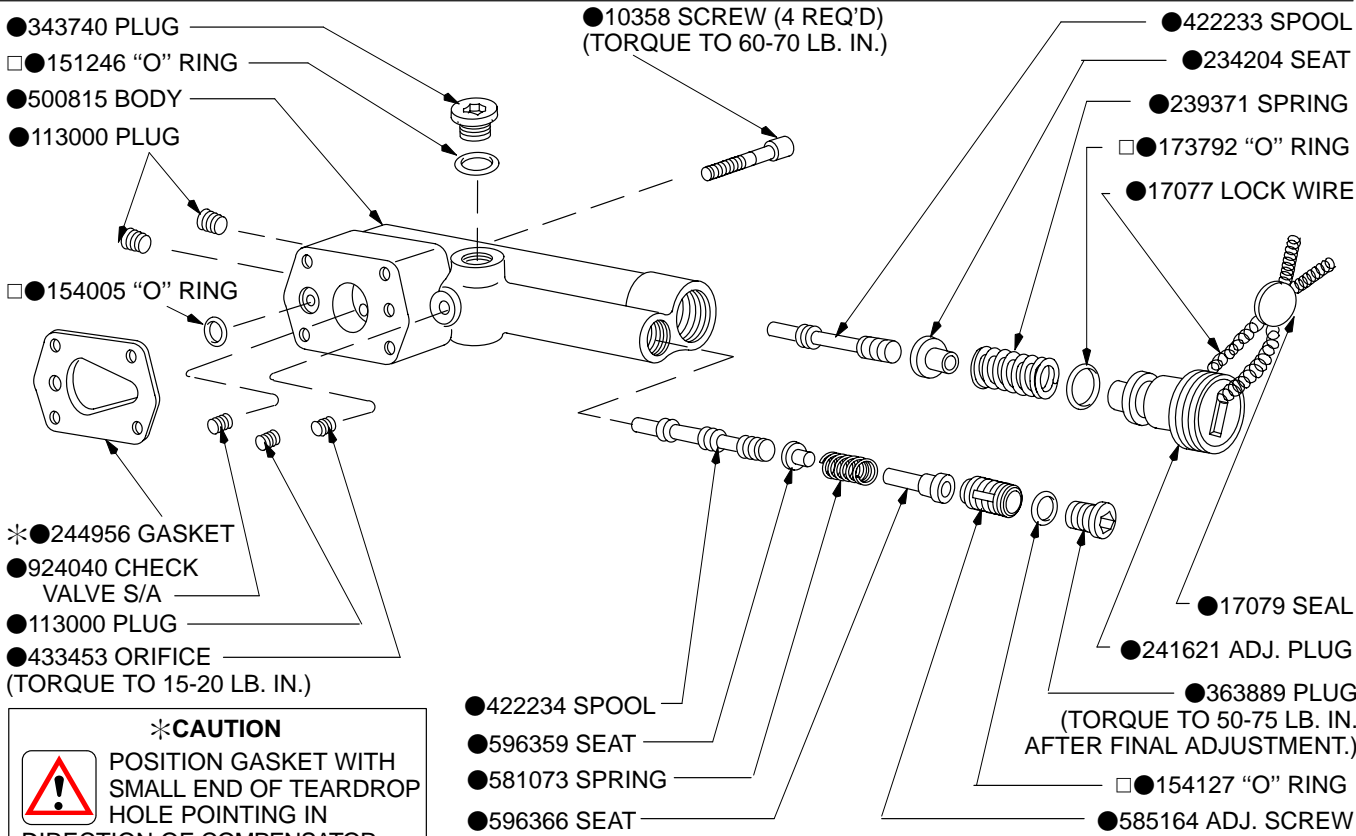

Vickers by Danfoss PVB Series Open Circuit Piston Pumps parts list

PVB-5 Thru 29-CVP-12



***CAUTION**
 POSITION GASKET WITH SMALL END OF TEARDROP HOLE POINTING IN DIRECTION OF COMPENSATOR ADJUSTING PLUGS.

CVP COMPENSATOR MOUNT FOR PVB-10/15/20/29 PUMP WITH R.H. SHAFT ROTATION OR PVB-5/6 PUMP WITH L.H. SHAFT ROTATION.

CVP COMPENSATOR MOUNT FOR PVB-10/15/20/29 PUMP WITH L.H. SHAFT ROTATION OR PVB-5/6 PUMP WITH R.H. SHAFT ROTATION.

● INCLUDED IN CVP-12 COMPENSATOR KIT 924069

□ **NOTE**
 REPLACEMENT SEALS FOR THE CVP COMPENSATOR ARE INCLUDED IN BASIC PUMP SEAL KIT.

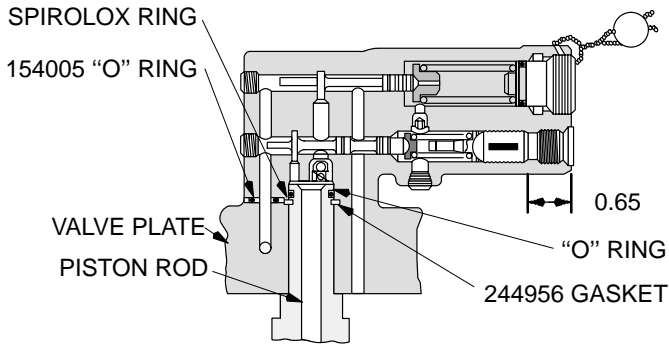
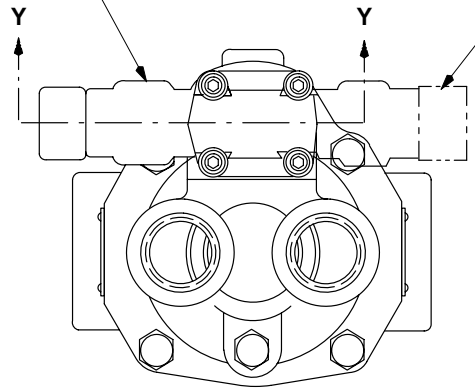

SECTION Y-Y

MODEL	BASIC PUMP PARTS DRAWING
PVB-5/6	I-3280-S, I-3261-S
PVB-10/15	I-3268-S, I-3282-S
PVB-20/29	I-3267-S, I-3293-S

CVP-12 Compensator Adjustment Procedure

Refer to front page and test circuit diagram. Perform the following steps:

1. Turn pressure limiting adjusting plug 241621 clockwise until seated. Turn in load sensing adjusting screw 585164 to approximately 0.65 inch. See sectional view Y-Y.
2. Operate the pump at the shaft speed (rpm) indicated in Table 1. Warm up system fluid to 110-130°F (38-54°C). Maintain 0-0,35 bar (0-5) psi at pump inlet.
3. Adjust valve 'A' to obtain 104 bar (1500 psi) at 'P2'.
4. Adjust valve 'B' to obtain a pump flow set point that is specified in Table 1.
5. Turn load sensing adjustment screw 585164 until 8.8-10.2 bar (140-180 psi) pressure differential is obtained between 'P1' and 'P2'.

MODEL	RPM	PUMP FLOW SET POINT	ΔP DIFFERENCE @ 95% FLOW
PVB5	2400	15 L/MIN (4 USGPM)	+5 / -15
PVB6		23 L/MIN (6 USGPM)	
PVB10		38 L/MIN (10 USGPM)	
PVB15	2000	45 L/MIN (12 USGPM)	
PVB20		57 L/MIN (15 USGPM)	
PVB29			

Table 1

6. Vary the pump outlet flow from 5,67 L/min (1.5 USgpm) to the pump flow set point with valve 'B'. A differential pressure reading should be within the value shown in Table 1. Differential pressure is defined as the pressure between the compensator cracking pressure (pressure at which the outlet flow equals 95% of full flow) and the pressure at the pump flow set point.

7. Turn pressure limiter adjustment plug 241621 counterclockwise until approximately .60 inch of threads are exposed. Close valve 'A'. Minimum pressure at 'P2' must not exceed 17 bar (250 psi) for PVB5/6/20/29 units or 24 bar (350 psi) for PVB10/20 units.
8. Turn the pressure limiter plug clockwise to retract the yoke to flow cutoff position (minimum stroke). Pressure at 'P2' must not exceed 140 bar (2000 psi) for PVB6/15/29 units, or 210 bar (3000 psi) for PVB5/10/20 units.
9. Shut down the system after the compensator adjustments are completed. Install 154127 "O" ring on 363889 plug. Install the plug into end of compensator body and tighten to 50-75 lb. in. (5.6-8.4 N.m).
10. Use a .089 drill bit and drill a hole through the compensator body and pressure limiter adjustment plug as shown in sectional view Y-Y.
11. Install lock wire into hole. Twist the wire and install the seal on the lock wire. Squeeze the seal to the lock wire with a suitable tool.

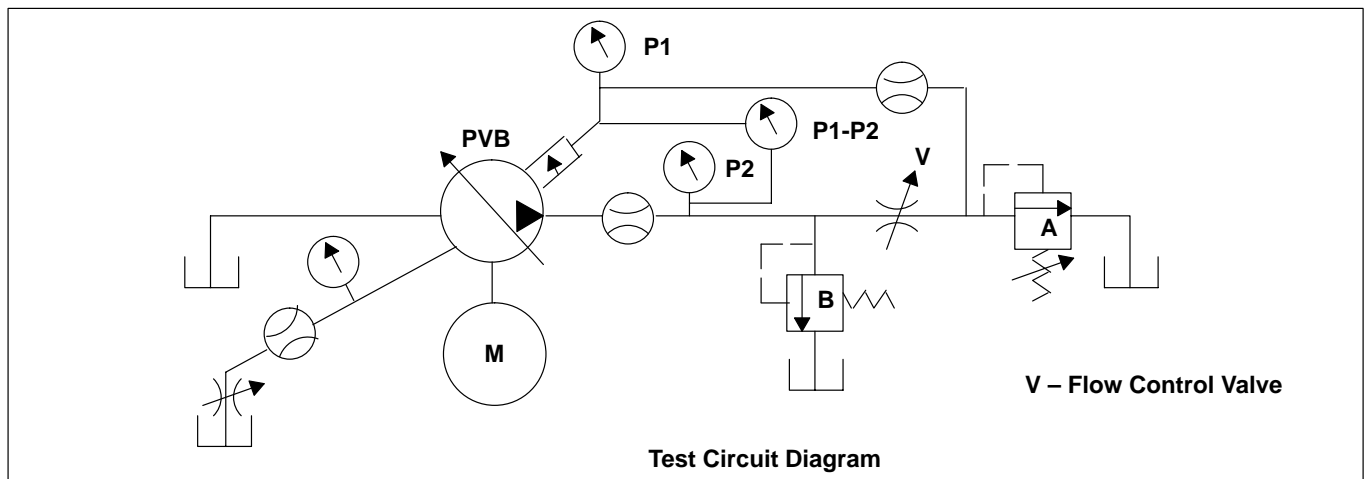

For satisfactory service life of these components, use full flow filtration to provide fluid which meets ISO cleanliness code 16/13 or cleaner. Selections from pressure, return, and in-line filter series are recommended.