

S26 Series Gear Pump Service Manual



EATON

Powering Business Worldwide

TABLE OF CONTENTS

SERIES 26 PUMPS

Features	3
General specifications and performance data	4
Performance data charts	5
Standard catalog assemblies - dimensions	9
Order numbers	10
Optional configurations	13
Component parts - dimensions	14
Model code - single	17
Model code - multiple	19
Side-load applications	22
Load sensing priority valve	24

Series 26 pump Features

Pressures to 3500 PSI and flow to 24.1 GPM

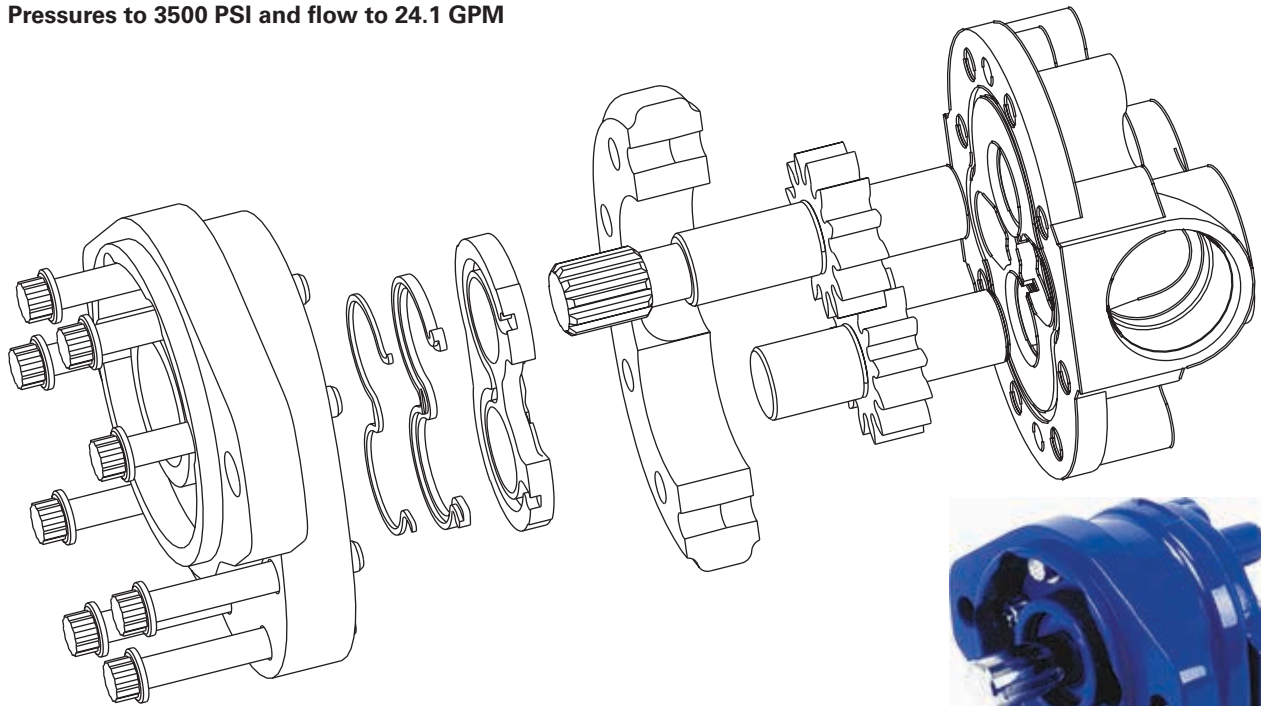

Quiet operation

- The 13-tooth gears, versus 10 teeth in previous pumps, minimizes the flow ripple. This reduces noise as well as vibration.
- The improved trap reliefs not only increase power, they also help keep oil flowing smoothly to reduce noise.

Improved efficiency

- Improved bearing lubrication system uses inlet oil instead of high pressure oil, improving volumetric efficiency for more power output.
- The highly polished shaft and gears improve mechanical efficiency and reduce wear on these components, adding to the service life and reliability of the pump.
- The optimized trapped oil relief areas help reduce pressure ripple for quieter operation. This also decreases the input power requirements.

Field reversible

- The innovative new wear plate permits simple field reversibility of the pump direction. Simply open the pump, switch the drive gear and idler gear, reposition the plug and reassemble. No extra parts are needed.

Interchangeability

- The Series 26 Gear Pump has been designed to retrofit equipment using the B1 and B2 Gear Pumps. Extra shafts, porting, and mounting configurations, as well as 13 available displacements, give you the choices you need for an easy conversion to this superior pump.

Series 26 pump

General specifications and performance data

Rotation	Field reversible
Mounting flange	SAE A 2 Bolt
Max. Continuous pressure†	210 bar [3000 PSI]*
Max. Intermittent pressure††	240 bar [3500 PSI]**
Minimum speed at continuous pressure	750 RPM
Maximum rotating torque at 0 pressure	4 Nm [36 lb-in]
Maximum continuous operating temperature	105°C [220°F]
Minimum continuous oil viscosity	5.7 cSt [45 SUS]
Minimum operating temperature	-29°C [-20°F]
Maximum inlet vacuum at operating condition	0,8 bar Abs. [11.6 psi Abs.]

† Continuous - pump may be run continuously at these ratings.

†† Intermittent - intermittent operation, 10% of every minute.

* 30.6 cm³/rev. [1.87 in³/rev.] displacement max. continuous pressure is 190 bar [2750 PSI].

** 30.6 cm³/rev. [1.87 in³/rev.] displacement max. intermittent pressure is 224 bar [3250 PSI].

For side load limits consult your Eaton representative.

Displacement cm³/r [in³/r]	6,6 [.40]	8,2 [.50]	9,5 [.58]	10,8 [.66]	13,8 [.84]	16,7 [1.02]	19,7 [1.20]
Max. Intermittent pressure bar [PSI]	241 [3500]	241 [3500]	241 [3500]	241 [3500]	241 [3500]	241 [3500]	241 [3500]
Rated speed (RPM)	3600	3600	3600	3600	3600	3600	3200
Minimum output flow at 207 bar [3000 PSI] and rated speed LPM [GPM]	20,1 [5.3]	25,0 [6.6]	29,5 [7.8]	33,7 [8.9]	43,5 [11.5]	55,3 [14.6]	57,9 [15.3]
Input power at 207 bar [3000 PSI] and rated speed and cont. Pressure kW [HP]	9,7 [13.0]	11,9 [15.9]	14,1 [18.9]	15,5 [20.8]	20,0 [26.8]	22,0 [29.4]	26,2 [35.2]

Displacement cm³/r [in³/r]	22,5 [1.37]	24,3 [1.48]	25,2 [1.54]	27,7 [1.69]	29,0 [1.77]	30,6 [1.87]
Max. Intermittent pressure bar [PSI]	241 [3500]	241 [3500]	241 [3500]	241 [3500]	234 [3400]	224 [3250]
Rated speed (RPM)	3000	3000	3000	3000	3000	3000
Minimum output flow at 207 bar [3000 PSI] and rated speed LPM [GPM]	62,1 [16.4]	67,0 [17.7]	69,7 [18.4]	76,5 [20.2]	79,9 [21.1]	84,4 [22.3]
Input power at 207 bar [3000 PSI] and rated speed and cont. Pressure kW [HP]	27,3 [36.6]	30,5 [40.9]	31,0 [41.6]	33,4 [44.8]	35,4 [47.4]	37,4 [50.1]

The performance data in the table above and the following graphs was collected using a mineral base oil with a viscosity of 133 SUS at 49°C [120°F].

Series 26 pump Performance data charts

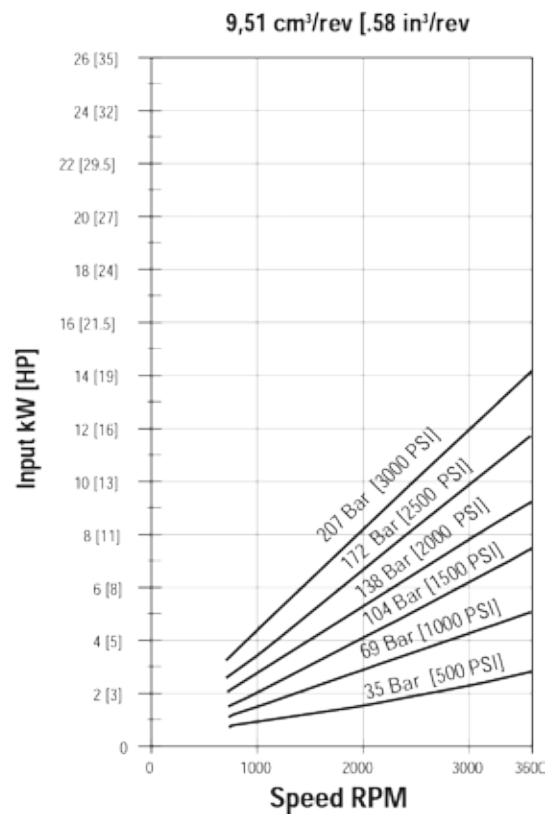
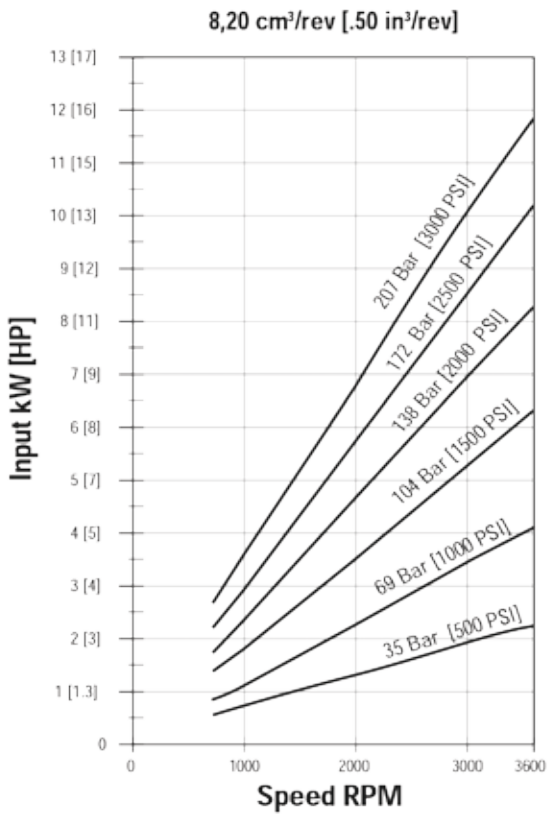
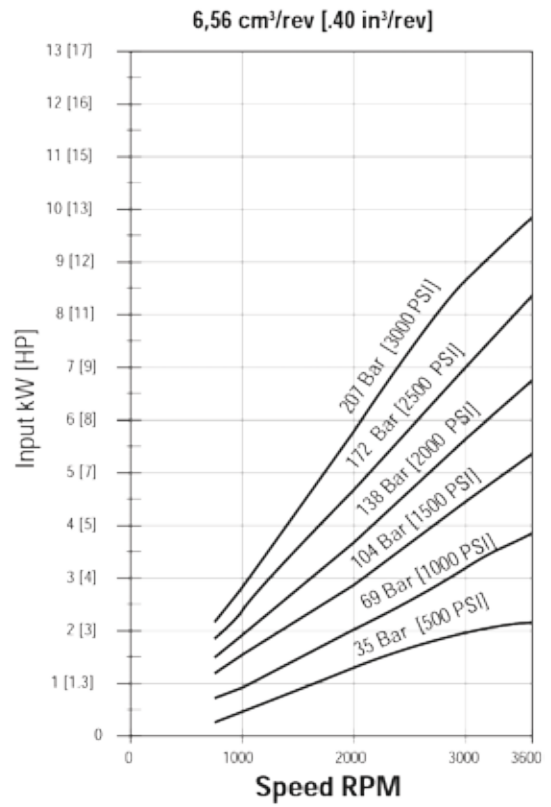
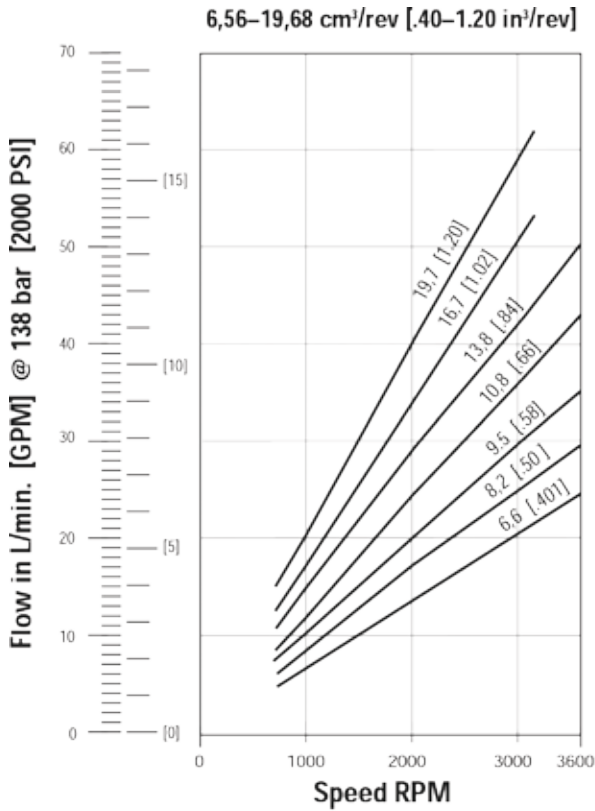

Series 26 pump Performance data charts

10,82 cm³/rev [.66 in³/rev]

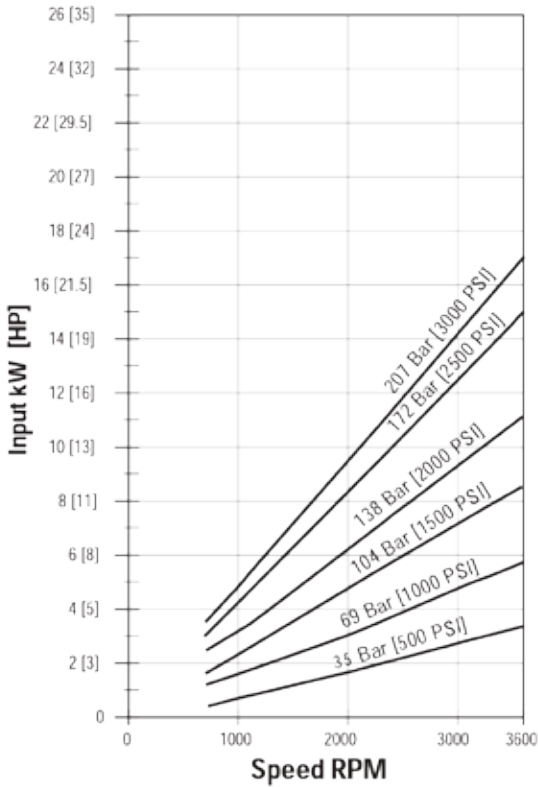

13,78 cm³/rev [.84 in³/rev]

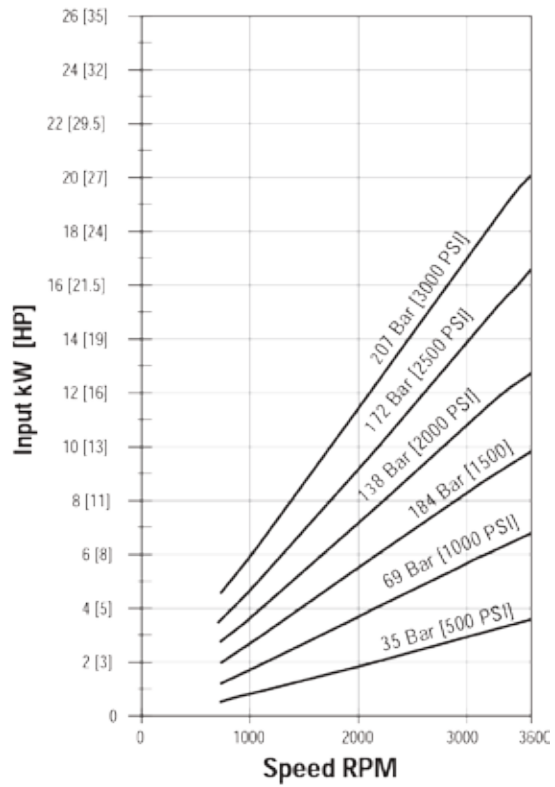

16,73 cm³/rev [1.02 in³/rev]

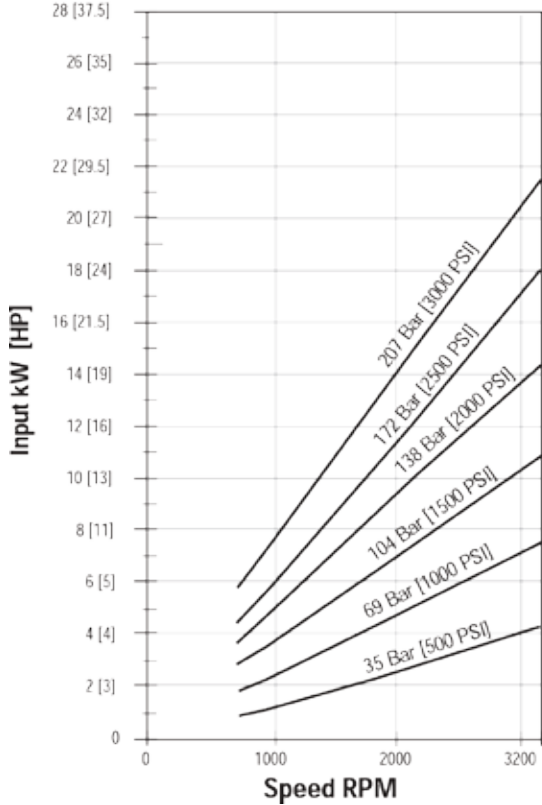

19,68 cm³/rev [1.20 in³/rev]

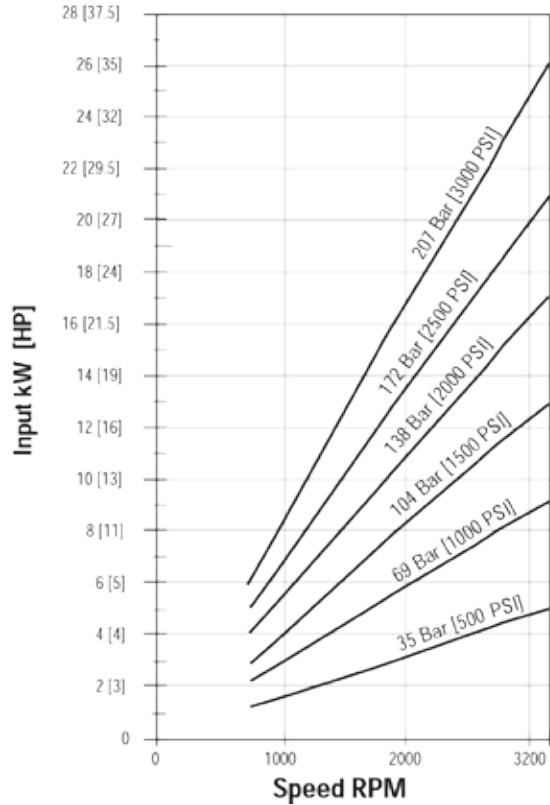

Series 26 pump Performance data charts

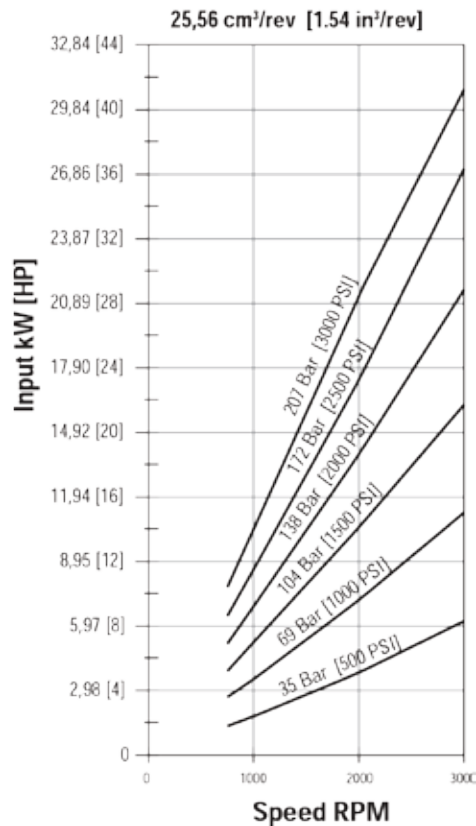
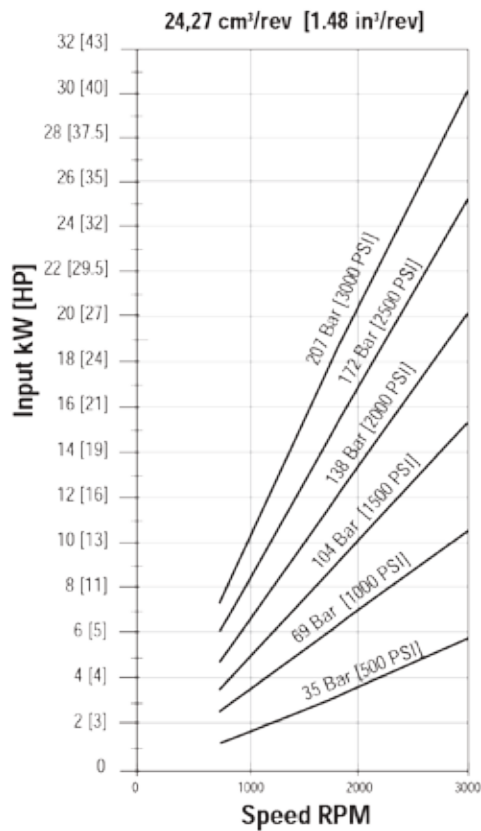
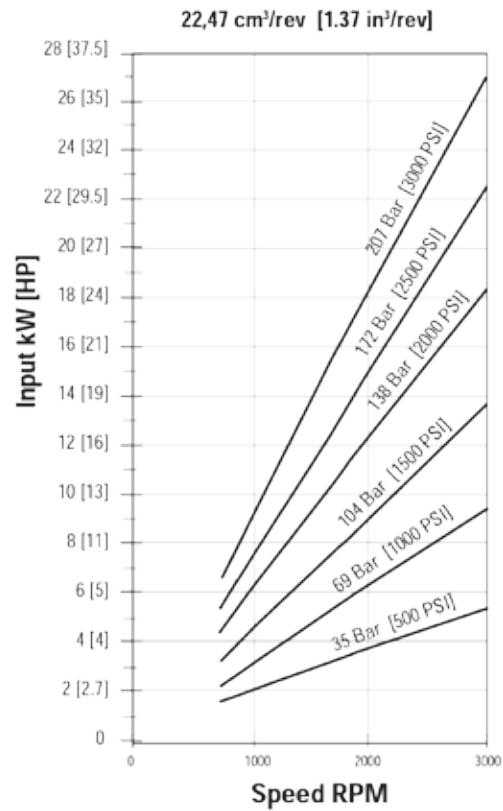
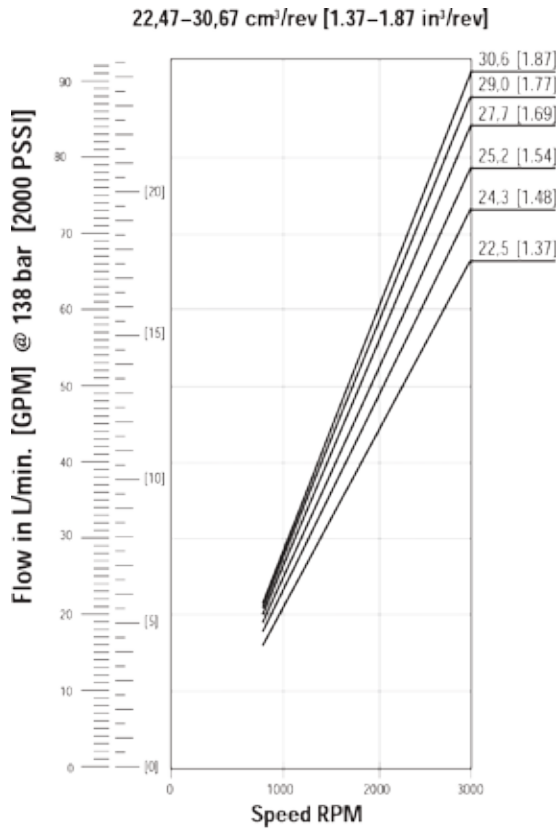

Series 26 pump Performance data charts

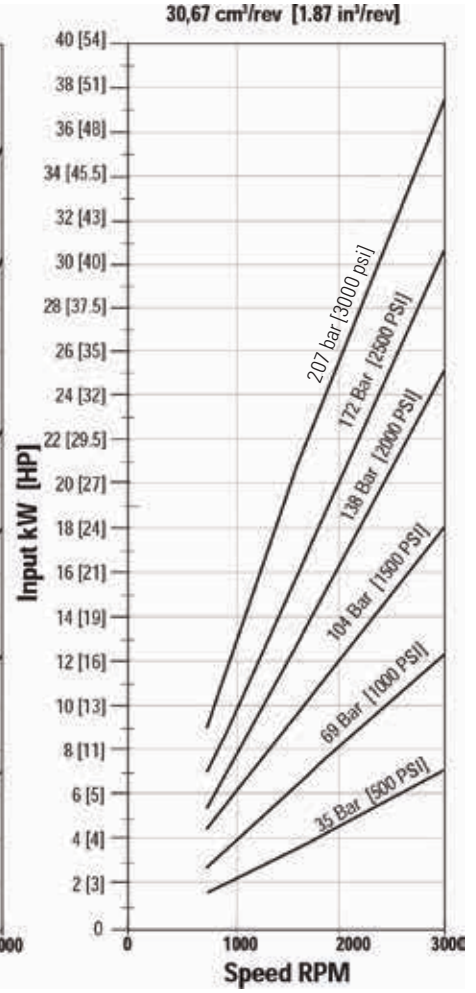
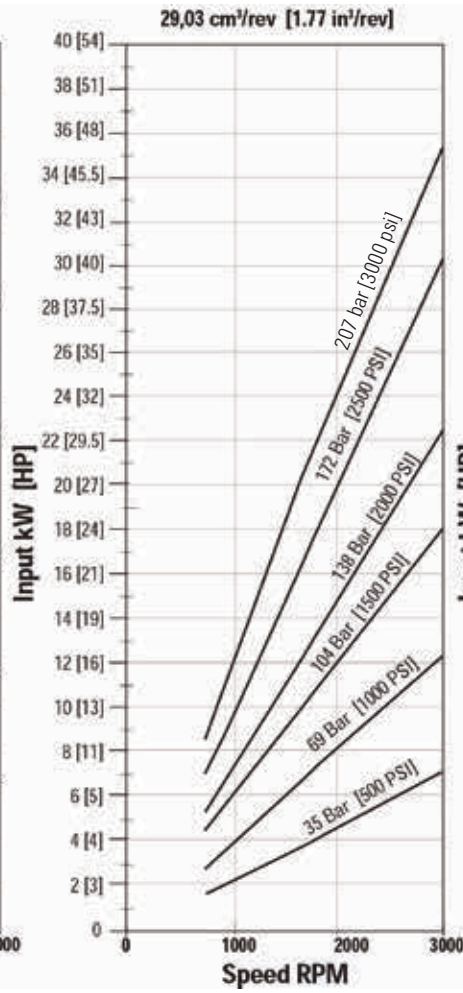
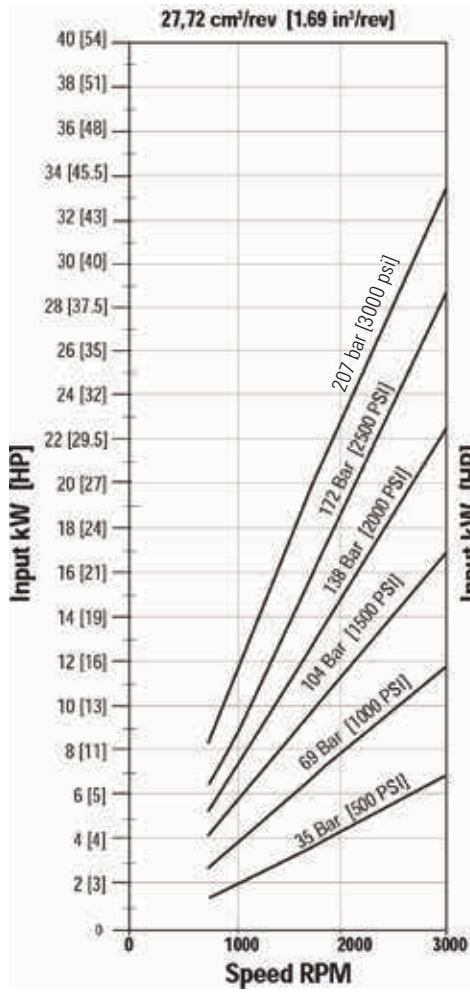

Series 26 pump Standard catalog assemblies - dimensions

***Multiple pump input torque limitations:**

The total torque for multiple pump displacements and pressure combinations cannot exceed the maximum input torque rating of the shaft. The proper formula is pressure times displacement divided by 6.28.

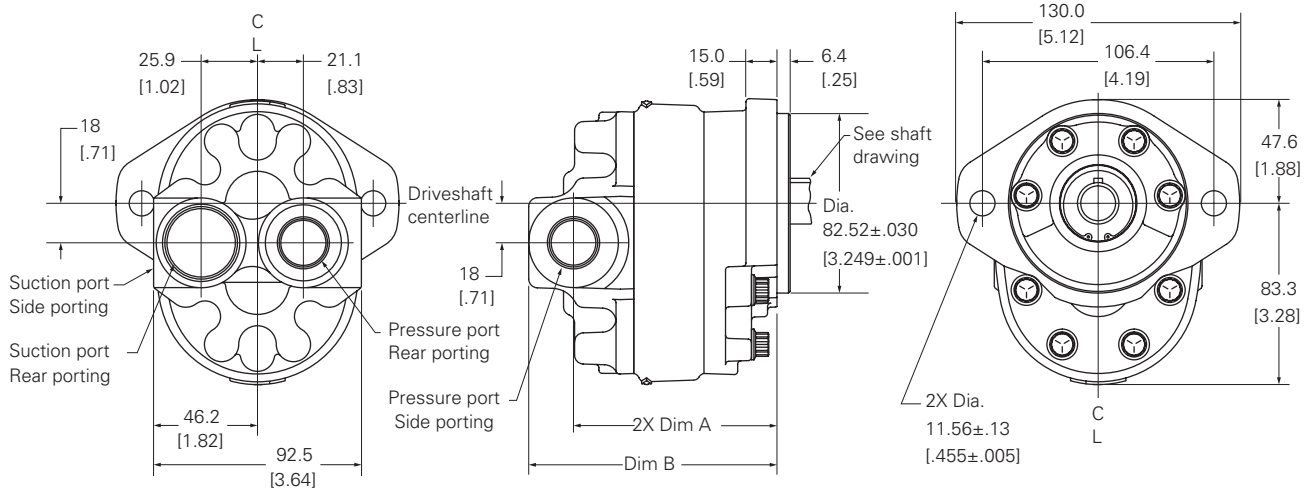

Left hand rotation shown

Model	26001	26002	26003	26004	26005	26006	26007
Displacement (cm ³ /r [in ³ /r])	6.6 [.40]	8.2 [.50]	9.5 [.58]	10.8 [.66]	13.8 [.84]	16.7 [1.02]	19.7 [1.20]
Dimension A (mm [in])	72.6 [2.86]	74.3 [2.93]	75.9 [2.99]	77.5 [3.05]	80.7 [3.18]	83.9 [3.30]	87.1 [3.43]
Dimension B (mm [in])	93.2 [3.67]	94.9 [3.74]	96.5 [3.80]	98.1 [3.86]	101.3 [3.99]	104.5 [4.11]	107.7 [4.24]

Model	26008	26009	26010	26011	26012	26013
Displacement (cm ³ /r [in ³ /r])	22.5 [1.37]	24.3 [1.48]	25.2 [1.54]	27.7 [1.69]	29.0 [1.77]	30.6 [1.87]
Dimension A (mm [in])	90.3 [3.56]	92.7 [3.65]	93.5 [3.68]	96.7 [3.81]	98.6 [3.88]	99.9 [3.93]
Dimension B (mm [in])	110.9 [4.37]	113.3 [4.46]	114.1 [4.49]	117.3 [4.62]	119.1 [4.69]	120.5 [4.74]

5/8 Inch 9 tooth spline
maximum input torque 62
nm [550 lb-in]

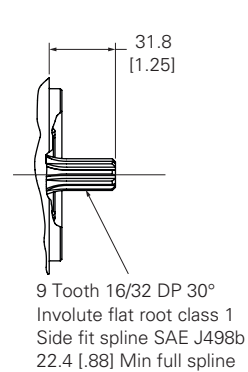

3/4 Inch 11 tooth spline
maximum input torque 119
nm [1050 lb-in]

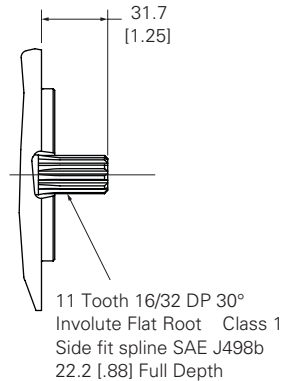

3/4 Inch straight key
maximum input torque 113
nm [1000 lb-in]

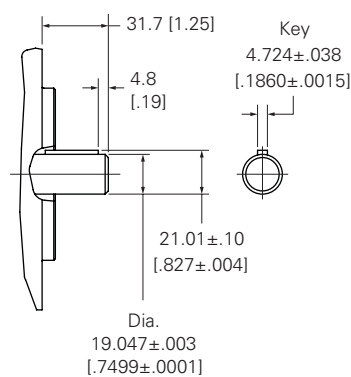

5/8 Inch straight key
maximum input torque 56
nm [500 lb-in]

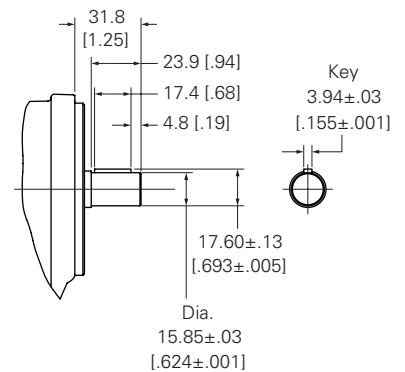

All dimensions are in mm

Series 26 pump Order numbers

Right hand rotation product no	Left hand rotation product no	Shaft	Port location	SAE O-ring pressure port size	SAE O-ring suction port size	Replaces
Model 26001 – 6,6 cm³/r [40 in³/r] displacement						
26001-RZG	26001-LZG	5/8 Keyed	Side	7/8-14 UNF-2B	1-1/16-12 UN-2B	24300-RZA/LZA
26001-RZH	26001-LZH	5/8 Keyed	Rear	7/8-14 UNF-2B	1-1/16-12 UN-2B	24300-RZC/LZD
26001-RZJ	26001-LZJ	5/8 9 T Spline	Side	7/8-14 UNF-2B	1-1/16-12 UN-2B	24300-RZB/LZA
26001-RZK	26001-LZK	5/8 9 T Spline	Rear	7/8-14 UNF-2B	1-1/16-12 UN-2B	24300-RZD/LZE
Model 26002 – 8,2 cm³/r [50 in³/r] displacement						
26002-RZA	26002-LZA	3/4 11T Spline	Side	7/8-14 UNF-2B	1-5/16-12 UN-2B	1-5/16-12 UN-2B
26002-RZB	26002-LZB	3/4 11T Spline	Rear	7/8-14 UNF-2B	1-5/16-12 UN-2B	1-5/16-12 UN-2B
26002-RZC	26002-LZC	3/4 Keyed	Side	7/8-14 UNF-2B	1-5/16-12 UN-2B	1-5/16-12 UN-2B
26002-RZD	26002-LZD	3/4 Keyed	Rear	7/8-14 UNF-2B	1-5/16-12 UN-2B	1-5/16-12 UN-2B
26002-RZE	26002-LZE	5/8 9 T Spline	Side	7/8-14 UNF-2B	1-5/16-12 UN-2B	1-5/16-12 UN-2B
26002-RZF	26002-LZF	5/8 9 T Spline	Rear	7/8-14 UNF-2B	1-5/16-12 UN-2B	1-5/16-12 UN-2B
26002-RZG	26002-LZG	5/8 Keyed	Side	7/8-14 UNF-2B	1-1/16-12 UN-2B	1-1/16-12 UN-2B
26002-RZH	26002-LZH	5/8 Keyed	Rear	7/8-14 UNF-2B	1-1/16-12 UN-2B	1-1/16-12 UN-2B
26002-RZJ	26002-LZJ	5/8 9 T Spline	Side	7/8-14 UNF-2B	1-1/16-12 UN-2B	1-1/16-12 UN-2B
26002-RZK	26002-LZK	5/8 9 T Spline	Rear	7/8-14 UNF-2B	1-1/16-12 UN-2B	1-1/16-12 UN-2B
Model 26003 – 9,5 cm³/r [58 in³/r] displacement						
26003-RZG	26003-LZG	5/8 Keyed	Side	7/8-14 UNF-2B	1-1/16-12 UN-2B	24302-RZB/LZB
26003-RZH	26003-LZH	5/8 Keyed	Rear	7/8-14 UNF-2B	1-1/16-12 UN-2B	24302-RZC/LZD
26003-RZJ	26003-LZJ	5/8 9 T Spline	Side	7/8-14 UNF-2B	1-1/16-12 UN-2B	24302-RZA/LZA
26003-RZK	26003-LZK	5/8 9 T Spline	Rear	7/8-14 UNF-2B	1-1/16-12 UN-2B	24302-RZD/LZE
Model 26004 – 10,8 cm³/r [66 in³/r] displacement						
26004-RZA	26004-LZA	3/4 11T Spline	Side	7/8-14 UNF-2B	1-5/16-12 UN-2B	25301-RSA/LSA
26004-RZB	26004-LZB	3/4 11T Spline	Rear	7/8-14 UNF-2B	1-5/16-12 UN-2B	25301-RSB/LSB
26004-RZC	26004-LZC	3/4 Keyed	Side	7/8-14 UNF-2B	1-5/16-12 UN-2B	25301-RSC/LSC
26004-RZD	26004-LZD	3/4 Keyed	Rear	7/8-14 UNF-2B	1-5/16-12 UN-2B	25301-RSD/LSD
26004-RZE	26004-LZE	5/8 9 T Spline	Side	7/8-14 UNF-2B	1-5/16-12 UN-2B	25301-RSE/LSE
26004-RZF	26004-LZF	5/8 9 T Spline	Rear	7/8-14 UNF-2B	1-5/16-12 UN-2B	25301-RSF/LSF
26004-RZG	26004-LZG	5/8 Keyed	Side	7/8-14 UNF-2B	1-1/16-12 UN-2B	24303-RZB/LZB
26004-RZH	26004-LZH	5/8 Keyed	Rear	7/8-14 UNF-2B	1-1/16-12 UN-2B	24303-RZE/LZF
26004-RZJ	26004-LZJ	5/8 9 T Spline	Side	7/8-14 UNF-2B	1-1/16-12 UN-2B	24303-RZD/LZA
26004-RZK	26004-LZK	5/8 9 T Spline	Rear	7/8-14 UNF-2B	1-1/16-12 UN-2B	24303-RZF/LZG
Model 26005 – 13,8 cm³/r [84 in³/r] displacement						
26005-RZA	26005-LZA	3/4 11T Spline	Side	7/8-14 UNF-2B	1-5/16-12 UN-2B	25302-RSA/LSA
26005-RZB	26005-LZB	3/4 11T Spline	Rear	7/8-14 UNF-2B	1-5/16-12 UN-2B	25302-RSB/LSB
26005-RZC	26005-LZC	3/4 Keyed	Side	7/8-14 UNF-2B	1-5/16-12 UN-2B	25302-RSC/LSC
26005-RZD	26005-LZD	3/4 Keyed	Rear	7/8-14 UNF-2B	1-5/16-12 UN-2B	25302-RSD/LSD
26005-RZE	26005-LZE	5/8 9 T Spline	Side	7/8-14 UNF-2B	1-5/16-12 UN-2B	25302-RSE/LSE
26005-RZF	26005-LZF	5/8 9 T Spline	Rear	7/8-14 UNF-2B	1-5/16-12 UN-2B	25302-RSF/LSF
26005-RZG	26005-LZG	5/8 Keyed	Side	7/8-14 UNF-2B	1-1/16-12 UN-2B	24304-RZC/LZA
26005-RZH	26005-LZH	5/8 Keyed	Rear	7/8-14 UNF-2B	1-1/16-12 UN-2B	24304-RZG/LZF
26005-RZJ	26005-LZJ	5/8 9 T Spline	Side	7/8-14 UNF-2B	1-1/16-12 UN-2B	24304-RZD/LZB
26005-RZK	26005-LZK	5/8 9 T Spline	Rear	7/8-14 UNF-2B	1-1/16-12 UN-2B	24304-RZH/LZG

* 5/8 9 T Spline has a maximum allowable input torque of 62 Nm [550 lb-in].

** 5/8 Keyed shaft has a maximum allowable input torque of 56 Nm [500 lb-in].

Series 26 pump Order numbers

Right hand rotation product no	Left hand rotation product no	Shaft	Port location	SAE O-ring pressure port size	SAE O-ring suction port size	Replaces
Model 26006 – 16,7 cm³/r [1.02 in³/r] displacement						
26006-RZA	26006-LZA	3/4 11T Spline	Side	7/8-14 UNF-2B	1-5/16-12 UN-2B	25303-RSA/LSA
26006-RZB	26006-LZB	3/4 11T Spline	Rear	7/8-14 UNF-2B	1-5/16-12 UN-2B	25303-RSB/LSB
26006-RZC	26006-LZC	3/4 Keyed	Side	7/8-14 UNF-2B	1-5/16-12 UN-2B	25303-RSC/LSC
26006-RZD	26006-LZD	3/4 Keyed	Rear	7/8-14 UNF-2B	1-5/16-12 UN-2B	25303-RSD/LSD
26006-RZE	26006-LZE	5/8 9 T Spline	Side	7/8-14 UNF-2B	1-5/16-12 UN-2B	25303-RSE/LSE
26006-RZF	26006-LZF	5/8 9 T Spline	Rear	7/8-14 UNF-2B	1-5/16-12 UN-2B	25303-RSF/LSF
26006-RZG	26006-LZG	5/8 Keyed	Side	7/8-14 UNF-2B	1-1/16-12 UN-2B	24305-RZC/LZA
26006-RZH	26006-LZH	5/8 Keyed	Rear	7/8-14 UNF-2B	1-1/16-12 UN-2B	24305-RZG/LZF
26006-RZJ	26006-LZJ	5/8 9 T Spline	Side	7/8-14 UNF-2B	1-1/16-12 UN-2B	24305-RZD/LZB
26006-RZK	26006-LZK	5/8 9 T Spline	Rear	7/8-14 UNF-2B	1-1/16-12 UN-2B	24305-RZH/LZG
Model 26007 – 19,7 cm³/r [1.20 in³/r] Displacement						
26007-RZA	26007-LZA	3/4 11T Spline	Side	7/8-14 UNF-2B	1-5/16-12 UN-2B	25304-RSA/LSA
26007-RZB	26007-LZB	3/4 11T Spline	Rear	7/8-14 UNF-2B	1-5/16-12 UN-2B	25304-RSB/LSB
26007-RZC	26007-LZC	3/4 Keyed	Side	7/8-14 UNF-2B	1-5/16-12 UN-2B	25304-RSC/LSC
26007-RZD	26007-LZD	3/4 Keyed	Rear	7/8-14 UNF-2B	1-5/16-12 UN-2B	25304-RSD/LSD
26007-RZE	26007-LZE	*5/8 9 T Spline	Side	7/8-14 UNF-2B	1-5/16-12 UN-2B	25304-RSE/LSE
26007-RZF	26007-LZF	*5/8 9 T Spline	Rear	7/8-14 UNF-2B	1-5/16-12 UN-2B	25304-RSF/LSF
26007-RZG	26007-LZG	**5/8 Keyed	Side	7/8-14 UNF-2B	1-1/16-12 UN-2B	24306-RZA/LZA
26007-RZH	26007-LZH	**5/8 Keyed	Rear	7/8-14 UNF-2B	1-1/16-12 UN-2B	24306-RZE/LZF
26007-RZJ	26007-LZJ	*5/8 9 T Spline	Side	7/8-14 UNF-2B	1-1/16-12 UN-2B	24306-RZD/LZB
26007-RZK	26007-LZK	*5/8 9 T Spline	Rear	7/8-14 UNF-2B	1-1/16-12 UN-2B	24306-RZF/LZG
Model 26008 – 22,5 cm³/r [1.37 in³/r] Displacement						
26008-RZA	26008-LZA	3/4 11T Spline	Side	7/8-14 UNF-2B	1-5/16-12 UN-2B	25305-RSA/LSA
26008-RZB	26008-LZB	3/4 11T Spline	Rear	7/8-14 UNF-2B	1-5/16-12 UN-2B	25305-RSB/LSB
26008-RZC	26008-LZC	3/4 Keyed	Side	7/8-14 UNF-2B	1-5/16-12 UN-2B	25305-RSC/LSC
26008-RZD	26008-LZD	3/4 Keyed	Rear	7/8-14 UNF-2B	1-5/16-12 UN-2B	25305-RSD/LSD
26008-RZE	26008-LZE	*5/8 9 T Spline	Side	7/8-14 UNF-2B	1-5/16-12 UN-2B	25305-RSE/LSE
26008-RZF	26008-LZF	*5/8 9 T Spline	Rear	7/8-14 UNF-2B	1-5/16-12 UN-2B	25305-RSF/LSF
Model 26009 – 24,3 cm³/r [1.48 in³/r] Displacement						
26009-RZG	26009-LZG	**5/8 Keyed	Side	7/8-14 UNF-2B	1-1/16-12 UN-2B	24307-RZC/LZA
26009-RZH	26009-LZH	**5/8 Keyed	Rear	7/8-14 UNF-2B	1-1/16-12 UN-2B	24307-RZG/LZF
26009-RZJ	26009-LZJ	*5/8 9 T Spline	Side	7/8-14 UNF-2B	1-1/16-12 UN-2B	24307-RZD/LZB
26009-RZK	26009-LZK	*5/8 9 T Spline	Rear	7/8-14 UNF-2B	1-1/16-12 UN-2B	24307-RZH/LZG
Model 26010 – 25,2 cm³/r [1.54 in³/r] Displacement						
26010-RZA	26010-LZA	3/4 11T Spline	Side	7/8-14 UNF-2B	1-5/16-12 UN-2B	25306-RSA/LSA
26010-RZB	26010-LZB	3/4 11T Spline	Rear	7/8-14 UNF-2B	1-5/16-12 UN-2B	25306-RSB/LSB
26010-RZC	26010-LZC	3/4 Keyed	Side	7/8-14 UNF-2B	1-5/16-12 UN-2B	25306-RSC/LSC
26010-RZD	26010-LZD	3/4 Keyed	Rear	7/8-14 UNF-2B	1-5/16-12 UN-2B	25306-RSD/LSD
26010-RZE	26010-LZE	*5/8 9 T Spline	Side	7/8-14 UNF-2B	1-5/16-12 UN-2B	25306-RSE/LSE
26010-RZF	26010-LZF	*5/8 9 T Spline	Rear	7/8-14 UNF-2B	1-5/16-12 UN-2B	25306-RSF/LSF

* 5/8 9 T Spline has a maximum allowable input torque of 62 Nm [550 lb-in].

** 5/8 Keyed shaft has a maximum allowable input torque of 56 Nm [500 lb-in].

Series 26 pump Order numbers

Right hand rotation product no	Left hand rotation product no	Shaft	Port location	SAE O-ring pressure port size	SAE O-ring suction port size	Replaces
Model 26011 – 27,7 cm³/r [1.69 in³/r] Displacement						
26011-RZA	26011-LZA	3/4 11T Spline	Side	7/8-14 UNF-2B	1-5/16-12 UN-2B	25307-RSA/LSA
26011-RZB	26011-LZB	3/4 11T Spline	Rear	7/8-14 UNF-2B	1-5/16-12 UN-2B	25307-RSB/LSB
26011-RZC	26011-LZC	3/4 Keyed	Side	7/8-14 UNF-2B	1-5/16-12 UN-2B	25307-RSC/LSC
26011-RZD	26011-LZD	3/4 Keyed	Rear	7/8-14 UNF-2B	1-5/16-12 UN-2B	25307-RSD/LSD
26011-RZE	26011-LZE	*5/8 9 T Spline	Side	7/8-14 UNF-2B	1-5/16-12 UN-2B	25307-RSE/LSE
26011-RZF	26011-LZF	*5/8 9 T Spline	Rear	7/8-14 UNF-2B	1-5/16-12 UN-2B	25307-RSF/LSF
Model 26012 – 29,0 cm³/r [1.77 in³/r] Displacement						
26012-RZG	26012-LZG	**5/8 Keyed	Side	7/8-14 UNF-2B	1-1/16-12 UN-2B	24308-RZA/LZA
26012-RZH	26012-LZH	**5/8 Keyed	Rear	7/8-14 UNF-2B	1-1/16-12 UN-2B	24308-RZE/LZF
26012-RZJ	26012-LZJ	*5/8 9 T Spline	Side	7/8-14 UNF-2B	1-1/16-12 UN-2B	24308-RZD/LZB
26012-RZK	26012-LZK	*5/8 9 T Spline	Rear	7/8-14 UNF-2B	1-1/16-12 UN-2B	24308-RZF/LZG
Model 26013 – 30,6 cm³/r [1.87 in³/r] Displacement						
26013-RZA	26013-LZA	3/4 11T Spline	Side	7/8-14 UNF-2B	1-5/16-12 UN-2B	25308-RZA/LZA
26013-RZB	26013-LZB	3/4 11T Spline	Rear	7/8-14 UNF-2B	1-5/16-12 UN-2B	25308-RZB/LZB
26013-RZC	26013-LZC	3/4 Keyed	Side	7/8-14 UNF-2B	1-5/16-12 UN-2B	25308-RZC/LZC
26013-RZD	26013-LZD	3/4 Keyed	Rear	7/8-14 UNF-2B	1-5/16-12 UN-2B	25308-RZD/LZD
26013-RZE	26013-LZE	*5/8 9 T Spline	Side	7/8-14 UNF-2B	1-5/16-12 UN-2B	25308-RZE/LZE
26013-RZF	26013-LZF	*5/8 9 T Spline	Rear	7/8-14 UNF-2B	1-5/16-12 UN-2B	25308-RZF/LZF

* 5/8 9 T Spline has a maximum allowable input torque of 62 Nm [550 lb-in].

** 5/8 Keyed shaft has a maximum allowable input torque of 56 Nm [500 lb-in].

Series 26 pump Optional configurations

The series 26 gear pump components can be assembled into many optional configurations. The versatile design allows you to assemble a pump to meet your specific needs.

Model codes for single and multiple pumps along with the component part dimension drawings are given on the following pages.

Single gear pump with tandem backplate

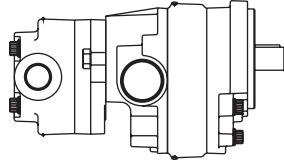

Double gear pump with tandem backplate

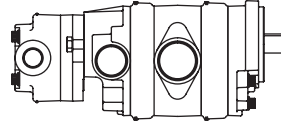

Triple gear pump with two suction ports and tandem backplate

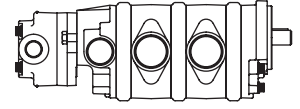

Single gear pump

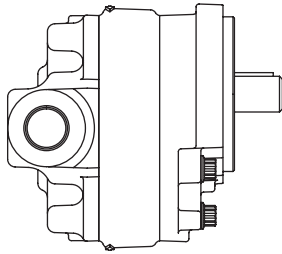

Double gear pump with common suction port

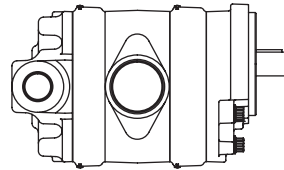

Single gear pump w/
tandem flow divider
backplate

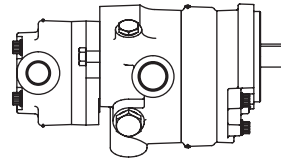

Double gear pump with
tandem flow divider
backplate

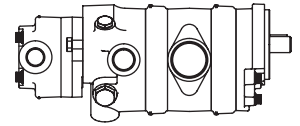

Triple gear pump with two
suction ports

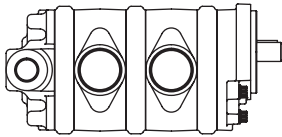

Triple gear pump with two
suction ports and tandem
flow divider backplate

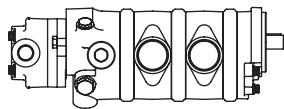

Single gear pump with
relief valve

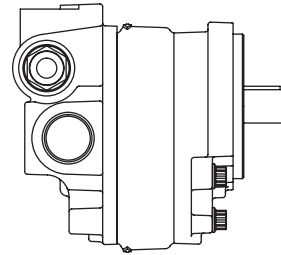

Double gear pump with
relief valve

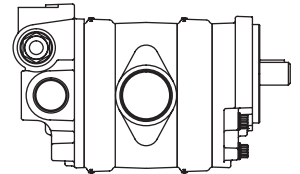

Single gear pump with flow
divider and relief valve

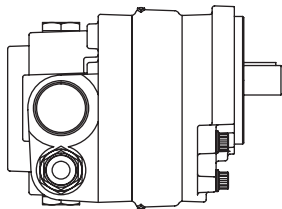

Double gear pump with
flow divider and relief valve

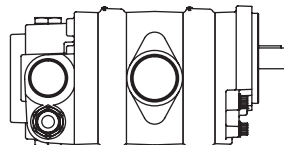

Triple gear pump with two
suction ports and relief
valve

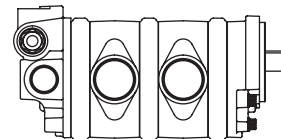

Triple gear pump with two
suction ports, flow divider
and relief valve

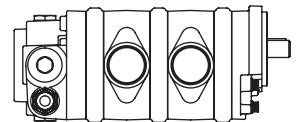

Series 26 pump

Component parts - dimensions

Front plate

SAE A 2 bolt flange used on all standard catalog assemblies

"B" Mount

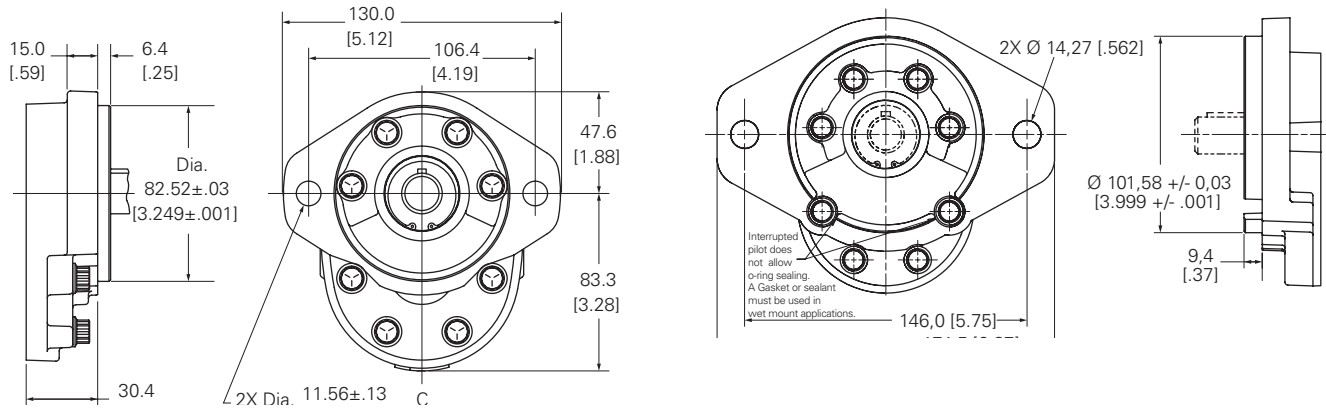

4 Bolt euro mount

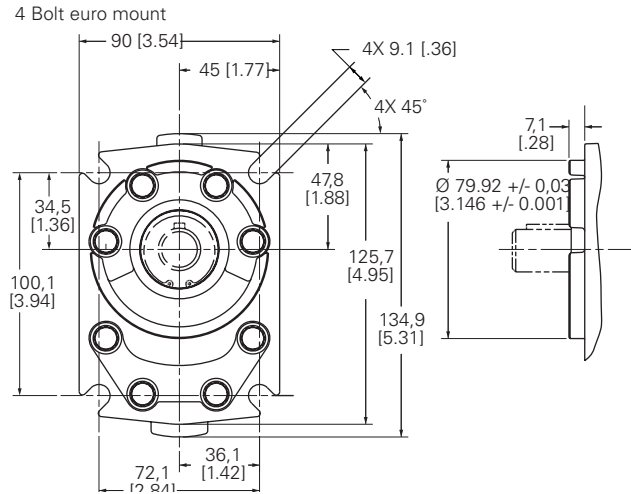

Body

Used on single and multiple pumps

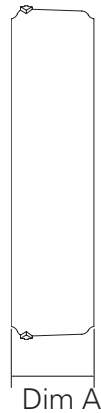

Model	26001	26002	26003	26004	26005	26006	26007
Displacement (cm ³ /r [in ³ /r])	6.6 [0.40]	8.2 [0.50]	9.5 [0.58]	10.8 [0.66]	13.8 [0.84]	16.7 [1.02]	19.7 [1.20]
Dimension A (mm [in])	14.4 [0.57]	16.3 [0.64]	17.7 [0.70]	19.5 [0.77]	22.7 [0.89]	25.9 [1.02]	29.1 [1.15]

Model	26008	26009	26010	26011	26012	26013
Displacement (cm ³ /r [in ³ /r])	22.5 [1.37]	24.3 [1.48]	25.2 [1.54]	27.7 [1.69]	29.0 [1.77]	30.6 [1.87]
Dimension A (mm [in])	32.3 [1.27]	34.7 [1.36]	35.5 [1.40]	38.7 [1.52]	40.3 [1.59]	41.9 [1.65]

All dimensions are in mm [in].

Series 26 pump Component parts - dimensions

Backplate

Used on single and multiple pumps

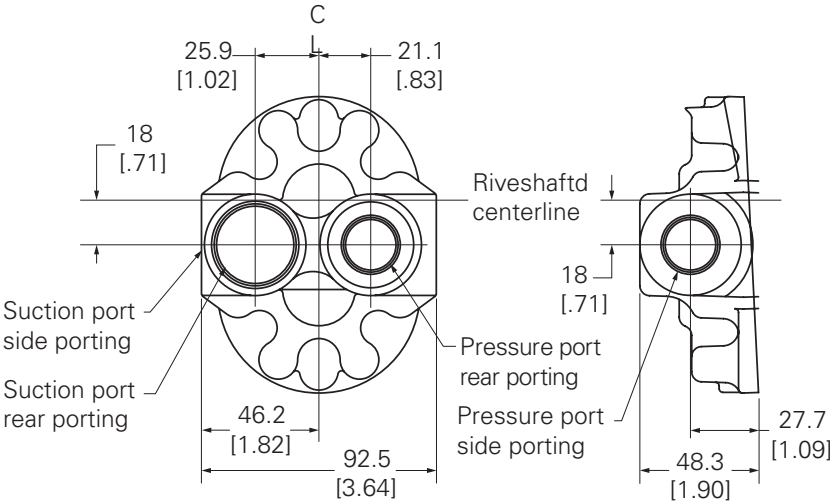

Left hand rotation shown

Flow divider backplate

Used on single and multiple pumps

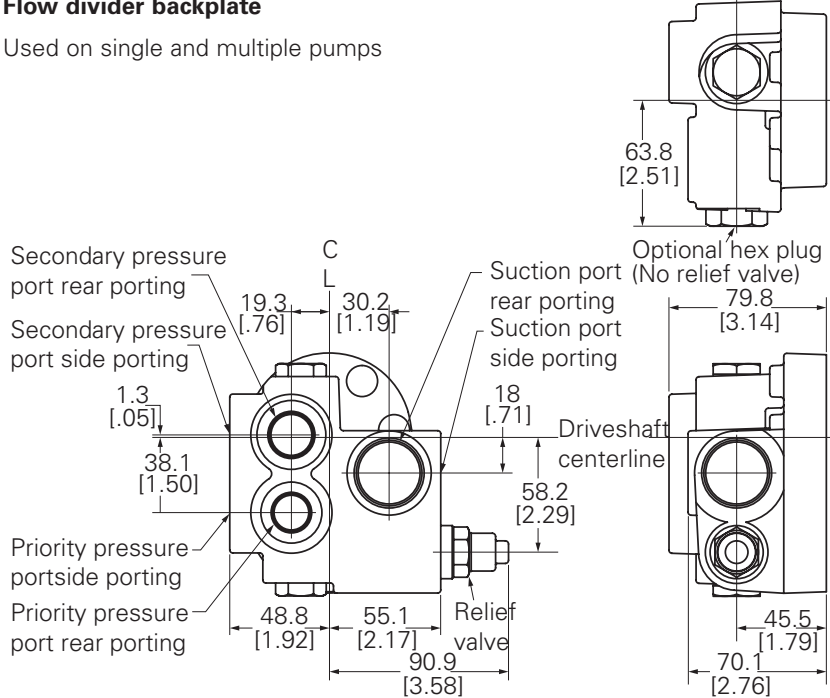

Right hand rotation shown

Right hand rotation shown

All dimensions are in mm [in].

Series 26 pump Component parts - dimensions

Relief valve backplate

Used on single and multiple pumps - right hand rotation shown

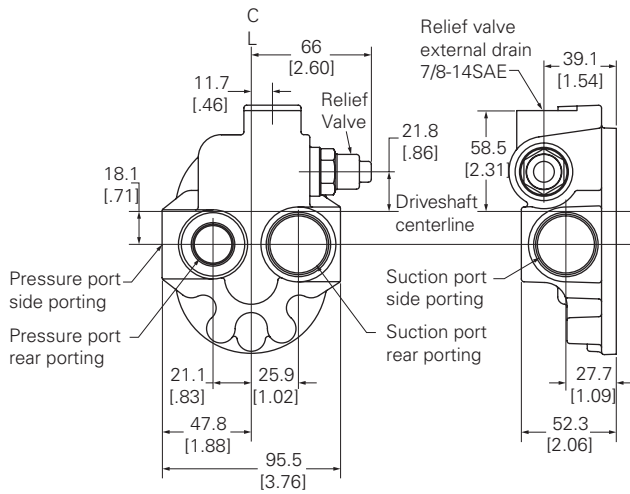

Adaptor plate

Used on multiple pumps - right hand rotation shown

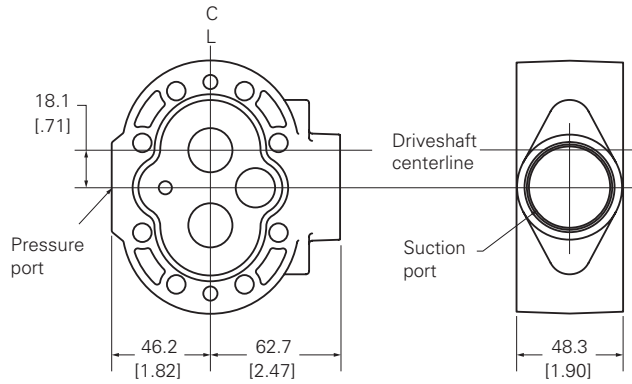

Tandem backplate

Used on single and multiple pumps SAE AA 2 bolt flange

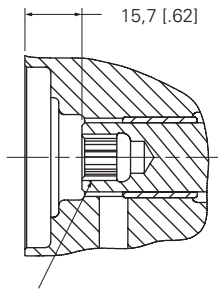

9 tooth 20/40 DP 30°
invlt flat rootclass I
side fit spline SAE J498b
9,7 [0.38] min. full spline

Max torque rating: 29.5 Nm [261 lbf•ft]

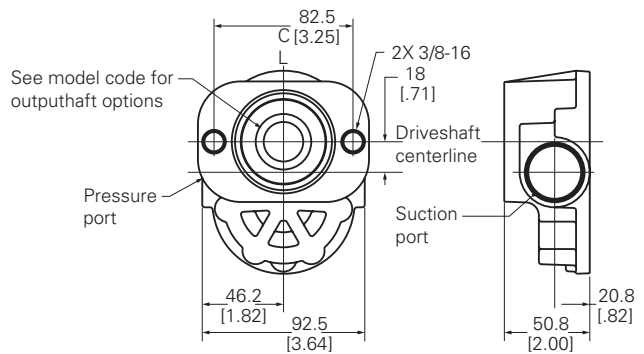

Right hand rotation shown

All dimensions are in mm [in].

Series 26 pump Model code single

Series 26 gear pumps can be ordered by using the following model code.

A twenty-four digit coding system has been designed to identify the features presently available on single gear pumps. The characters and their relative positions within the code identify specific features.

Use the model code matrix as an aid when assembling the model code for the pump with the features you desire. It may be helpful to photocopy the matrix and write the numbers and letters into the boxes as you select features.

All twenty-four digits of the code must be submitted when ordering.

ACN			*	*	**	**	A	0	00	00	00	0	00	00	0	A							
1	2	3	4	5	6	7	8	9	10	11	12	13	14	15	16	17	18	19	20	21	22	23	24

1 2 3 26 Series

ACN Gear pump - single unit

4 Unit type

A Plain
B Flow divider with/without relief valve (pos. 14-15)
C Relief valve (pos. 16-17)

5 Input rotation (viewed from input shaft end)

L Left-hand rotation CCW
R Right-hand rotation CW

6 7 Displacement (cm³/r [in³/r])

01 6.6 [.40]
02 8.2 [.50]
03 9.5 [.58]
04 10.8 [.66]
05 13.8 [.84]
06 16.7 [1.02]
07 19.7 [1.20]
08 22.5 [1.37]
09 24.3 [1.48]
10 25.2 [1.54]
11 27.7 [1.69]
12 29.0 [1.77]
13 30.6 [1.87]

8 9 Input shaft

AA 5/8 Inch dia. 9 Tooth spline 16/32 pitch shaft extension 31.8 [1.25]
AB 3/4 Inch dia. 11 Tooth spline 16/32 pitch shaft extension 31.8 [1.25]
AC 3/4 Inch dia. Straight keyed, keyway 4.8 X 25.4 [.19 X 1.00] Shaft extension 31.8 [1.25]
AD 5/8 Inch dia. Straight keyed, keyway 4.1 X 18.3 [.16 X .72] Shaft extension 31.8 [1.25]

10 Mounting features

A SAE 2-bolt a flange, series 82-2
B SAE 2-bolt A flange with thru drain
C SAE 2-bolt b flange, series 101-2
D European 4-bolt

11 Auxiliary mounting features

0 No rear mounting
C (2-Bolt AA) SAE flange series 50-2, with 9 tooth internal spline 20/40 pitch, accepts 25.4 [1.00] Shaft extension

12 13 Ports, sizes and location- backplate

01 Plain: suction port 1.3125-12 UN-2B SAE O-ring port; pressure port .875-14 UNF-2B SAE O-ring port - side sports
02 Plain: suction port 1.3125-12 UN-2B SAE O-ring port; pressure port .875-14 UNF-2B SAE O-ring port - rear ports
03 Plain: suction port 1.0625-12 UN-2B SAE O-ring port; pressure port .875-14 UNF-2B SAE O-ring port accepts fittings per SAE J1926 - side ports
04 Plain: suction port 1.0625-12 UN-2B SAE O-ring port; pressure port .875-14 UNF-2B SAE O-ring port accepts fittings per SAE J1926 -rear ports
08 Plain thru shaft: suction port 1.0625-12 UN-2B SAE Oring port; pressure port .875-14 UNF-2B SAE O-ring port - side ports
15 Relief valve: suction port 1.0625-12 UN-2B SAE O-ring port; pressure port .875-14 UNF-2B SAE O-ring port - side ports; drain port .875-14 UNF- 2B SAE O-ring port
16 Relief valve: suction port 1.0625-12 UN-2B SAE O-ring port; pressure port .875-14 UNF-2B SAE O-ring port - rear ports; drain port .875-14 UNF- 2B SAE O-ring port
20 Flow divider: suction port 1.3125-12 UN-2B SAE O-ring port; priority pressure port .750-16 UNF-2B SAE Oring port; secondary pressure port .875-14 UNF-2B SAE Oring Port - Side Ports

All dimensions are in inches.

Series 26 pump

Model code single

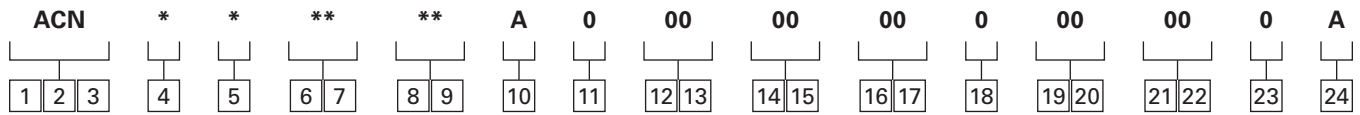

21 Flow Divider: Suction Port 1.3125-12 UN-2B SAE O-ring Port; Priority Pressure Port .750-16 UNF-2B SAE Oring Port; Secondary Pressure Port .875-14 UNF-2B SAE Oring Port - Rear Ports

14 15 **Priority flow divider setting (LPM [GPM])**

- 00** No Flow Setting
- AA** 3.8 [1.00]
- AD** 7.6 [2.00]
- AJ** 11.4 [3.00]
- AL** 15.1 [4.00]
- AN** 18.9 [5.00]
- AR** 22.7 [6.00]
- AS** 26.5 [7.00]
- AT** 30.3 [8.00]

16 17 **Relief valve full flow setting (bar [PSI])**

- 00** No Relief Valve Setting
- AA** 34.5 [500]
- AB** 51.7 [750]
- AC** 68.9 [1000]
- AE** 86.2 [1250]
- AF** 103.4 [1500]
- AJ** 120.7 [1750]
- AL** 137.9 [2000]
- AN** 155.1 [2250]
- AP** 172.4 [2500]
- AR** 189.6 [2750]
- AS** 206.8 [3000]
- BR** 241.3 [3500]
- BT** 224.1 [3250]

18 **Test Data**

- 0** Generic
- A** A - Unit Specific (required for flow divider and relief valve options.)

19 20 **Special features**

- 00** No Special Features
- AB** Viton Shaft Seal

21 22 **Paint**

- 00** None
- 0A** Red Primer
- 0B** Black

23 **Identification**

- 0** Standard

24 **Design code**

- A** A

All dimensions are in inches.

Series 26 pump Model code multiple

Series 26 Gear Pumps can be ordered by using the following Model Code.

A thirty-two digit coding system has been designed to identify the features presently available on Multiple gear

pumps. The characters and their relative positions within the code identify specific features. Use the Model Code Matrix as an aid when assembling the model code for the pump with the features you desire. It may be helpful

to photocopy the matrix and write the numbers and letters into the boxes as you select features.

All thirty-two digits of the code must be submitted when ordering.

ACM	*	*	**	**	**	**	**	**	**	00	00	A	0	0	00	00	0	B													
1	2	3	4	5	6	7	8	9	10	11	12	13	14	15	16	17	18	19	20	21	22	23	24	25	26	27	28	29	30	31	32

1	2	3	26 Series
			ACM Gear Pump - Multiple Unit
4	Unit type		
	A	Plain	
	B	Flow Divider with/without Relief Valve (Pos. 20-21)	
	C	Relief Valve	
5	Input rotation (viewed from input shaft end)		
	L	Left-hand Rotation CCW	
	R	Right-hand Rotation CW	
6	7	Displacement - front (cm³/r [in³/r])	
	01	6.6 [.40]	
	02	8.2 [.50]	
	03	9.5 [.58]	
	04	10.8 [.66]	
	05	13.8 [.84]	
	06	16.7 [1.02]	
	07	19.7 [1.20]	
	08	22.5 [1.37]	
	09	24.3 [1.48]	
	10	25.2 [1.54]	
	11	27.7 [1.69]	
	12	29.0 [1.77]	
	13	30.6 [1.87]	
8	9	Displacement - Ctr. triple only (cm³/r [in³/r])	
	01	6.6 [.40]	
	02	8.2 [.50]	
	03	9.5 [.58]	
	04	10.8 [.66]	
	05	13.8 [.84]	
	06	16.7 [1.02]	
	07	19.7 [1.20]	
	08	22.5 [1.37]	
	09	24.3 [1.48]	
	10	25.2 [1.54]	
	11	27.7 [1.69]	
	12	29.0 [1.77]	
	13	30.6 [1.87]	
	99	No Center Displacement	

10	11	Displacement - front (cm³/r [in³/r])	
	01	6.6 [.40]	
	02	8.2 [.50]	
	03	9.5 [.58]	
	04	10.8 [.66]	
	05	13.8 [.84]	
	06	16.7 [1.02]	
	07	19.7 [1.20]	
	08	22.5 [1.37]	
	09	24.3 [1.48]	
	10	25.2 [1.54]	
	11	27.7 [1.69]	
	12	29.0 [1.77]	
	13	30.6 [1.87]	
12	13	Input shaft	
	AA	5/8 Inch Dia. 9 Tooth Spline 16/32 Pitch Shaft Extension 31.8 [1.25]	
	AB	3/4 Inch Dia. 11 Tooth Spline 16/32 Pitch Shaft Extension 31.8 [1.25]	
	AC	3/4 Inch Dia. Straight Keyed, Keyway 4.8 x 25.4 [.19 x 1.00] Shaft Extension 31.8 [1.25]	
	AD	5/8 Inch Dia. Straight Keyed, Keyway 4.1 X 18.3 [.16 X .72] Shaft Extension 31.8 [1.25]	
14	15	Front adapter ports	
	01	Suction Port 1-5/8-12 UN-2B SAE O-ring Port; Pressure Port 7/8-14 UNF-2B SAE O-ring Port	
	05	Suction Port 1-5/16-12 UN-2B SAE O-ring Port; Pressure Port 7/8-14 UNF-2B SAE O-ring Port	
16	17	Ports - rear adapter (triple units)	
	00	No Rear Adaptor	
	01	Suction Port 1-5/8-12 UN-2B SAE O-ring Port; Pressure Port 7/8-14 UNF-2B SAE O-ring Port	
	05	05 = Suction Port 1-5/16-12 UN-2B SAE O-ring Port; Pressure Port 7/8-14 UNF-2B SAE O-ring Port	

All dimensions are in inches.

Series 26 pump

Model code multiple

ACM	*	*	**	**	**	**	**	**	**	00	00	A	0	0	00	00	0	B													
1	2	3	4	5	6	7	8	9	10	11	12	13	14	15	16	17	18	19	20	21	22	23	24	25	26	27	28	29	30	31	32

18	19	Ports, sizes and location- backplate
01		Plain: Suction Port 1-5/16-12 UN-2B SAE O-ring Port Size; Pressure Port 7/8-14 UNF-2B SAE O-ring Port-Side Ports
02		Plain: Suction Port 1-5/16-12 UN-2B SAE O-ring Port Size; Pressure Port 7/8-14 UNF-2B SAE O-ring Port-Rear Ports
03		Plain: Suction Port 1-1/16-12 UN-2B SAE O-ring Port Size; Pressure Port 7/8-14 UNF-2B SAE O-ring Port-Side Ports
04		Plain: Suction Port 1-1/16-12 UN-2B SAE O-ring Port Size; Pressure Port 7/8-14 UNF-2B SAE O-ring Port-Rear Ports
08		Plain Tandem: Suction Port 1.0625-12 UN-2B SAE Oring Port; Pressure Port .875-14 UNF-2B SAE O-ring Port - Side Ports
14		Plain: Suction Port 1-5/16-12 UN-2B SAE O-ring Port Size-(Plugged); Pressure Port 7/8-14 UNF-2B SAE O-ring Port-Side Ports, used with position 14 and 15-01 and 16 and 17-10
17		Plain: Suction Port 1-5/16-12 UN-2B SAE O-ring Port Size-(Plugged); Pressure Port 7/8-14 UNF-2B SAE O-ring Port-Rear Ports, used with position 14 and 15-01 and 16 and 17-01
18		Plain Tandem: Suction Port 1.0625-12 UN-2B SAE Oring Port (Plugged); Pressure Port .875-14 UNF-2B SAE Oring Port - Side Ports
19		Plain: Suction Port 1.3125-12 UN-2B SAE O-ring Port (Plugged); Pressure Port 1.0625-12 UN-2B SAE O-ring Port - Side Ports
20		Relief Valve: Suction Port 1.0625-12 UN-2B SAE O-ring Port; Pressure Port .875-14 UNF-2B SAE O-ring Port - SIDE Ports; DRAIN Port .875- 14 UNF-2B SAE O-ring Port
21		Relief Valve: Suction Port 1.0625-12 UN-2B SAE O-ring Port; Pressure Port .875-14 UNF-2B SAE O-ring Port - Rear Ports; DRAIN Port .875-14 UNF-2B SAE O-ring Port - TOP Port

27	Flow Divider: Suction Port 1.3125-12 UN-2B SAE Oring Port; Priority Pressure Port .750-16 UNF-2B SAE Oring Port; Secondary Pressure Port .875-14 UNF-2B SAE Oring Port - SIDE Ports
28	Flow Divider: Suction Port 1.3125-12 UN-2B SAE Oring Port; Priority Pressure Port .750-16 UNF-2B SAE Oring Port; Secondary Pressure Port .875-14 UNF-2B SAE Oring Port - Rear Ports
29	Flow Divider: Suction Port 1.0625-12 UN-2B SAE Oring Port; Priority Pressure Port .5625-18 UNF-2B SAE Oring Port; Secondary Pressure Port .875-14 UNF-2B SAE Oring Port - SIDE Ports

Consult your Eaton representative when requiring common inlet option.

20	21	Priority flow divider setting (LPM [GPM])
00		No Flow Setting
AA		3.8 [1.00]
AD		7.6 [2.00]
AJ		11.4 [3.00]
AL		15.1 [4.00]
AN		18.9 [5.00]
AR		22.7 [6.00]
AS		26.5 [7.00]
AT		30.3 [8.00]

22	23	Relief valve full flow setting (bar [PSI])
00		No Relief Valve Setting
AA		34.5 [500]
AB		51.7 [750]
AC		68.9 [1000]
AE		86.2 [1250]
AF		103.4 [1500]
AJ		120.7 [1750]
AL		137.9 [2000]
AN		155.1 [2250]
AP		172.4 [2500]
AR		189.6 [2750]
AS		206.8 [3000]

All dimensions are in inches.

Series 26 pump Model code multiple

ACM	*	*	**	**	**	**	**	**	**	**	00	00	A	0	0	00	00	0	B												
┌───┐	┌┐	┌┐	┌──┐	┌──┐	┌──┐	┌──┐	┌──┐	┌──┐	┌──┐	┌──┐	┌──┐	┌──┐	┌┐	┌┐	┌┐	┌──┐	┌──┐	┌┐	┌┐												
1	2	3	4	5	6	7	8	9	10	11	12	13	14	15	16	17	18	19	20	21	22	23	24	25	26	27	28	29	30	31	32

24	Mounting features (front)	<p>A (2-Bolt A) SAE Flange, Series 82-3</p> <p>C (2-Bolt B) SAE Flange Series 82.3</p> <p>G (4-Bolt) European</p>
----	----------------------------------	--

25	Auxiliary mounting features	<p>0 No Rear Mounting</p> <p>C (2-Bolt AA) SAE Flange Series 50-2, with 9 Tooth Internal Spline 20/40 Pitch, Accepts 25.4 [1.00] Shaft Extension</p>
----	------------------------------------	--

26	Test data	<p>0 Generic</p> <p>A Unit Specific (required for flow divider and relief valve options.)</p>
----	------------------	---

27	28	Special features	<p>00 No Special Features</p> <p>AB Viton Shaft Seal</p>
----	----	-------------------------	--

29	30	Paint	<p>00 None</p> <p>0A Red Primer</p> <p>0B Black</p>
----	----	--------------	--

31	Identification	<p>0 Standard</p>
----	-----------------------	--------------------------

32	Design code	<p>B B</p>
----	--------------------	-------------------

All dimensions are in inches.

Series 26 pump Side-load applications

Maximum allowable operating pressures

Ideal positions shown. Side load is acceptable within 90° of either side of the ideal position. Charts are based on 100% slack side tension. Max. speed per catalog. Max. operating pressure shown.

Gear drive

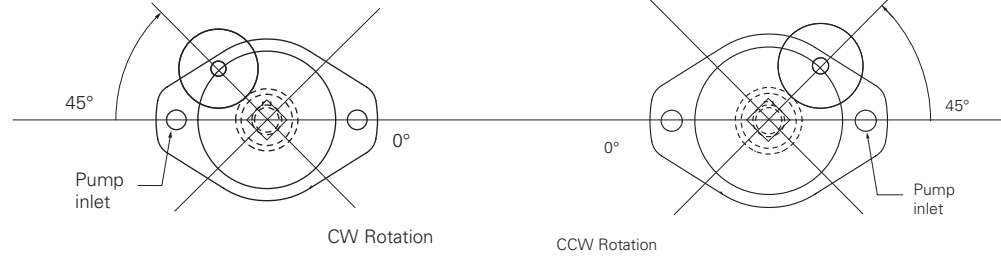

Pulley drive

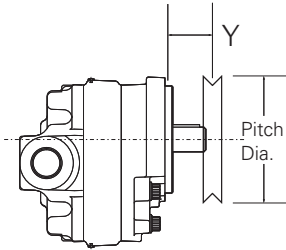
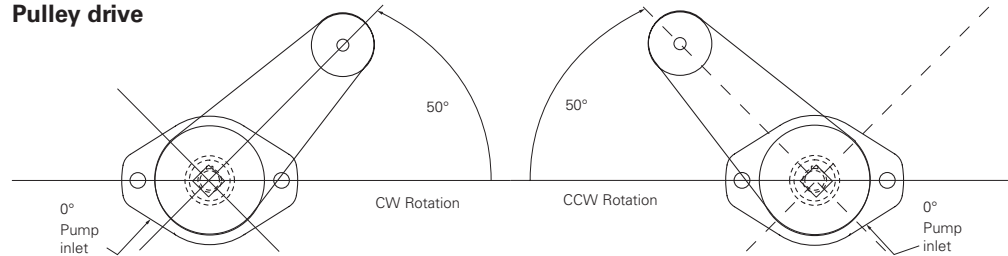

0.40/0.50 CID

Pulley Ø	2	4	6	8	10	12
Gear pitch Ø	1	2	3	4	5	6
Y Dimension						
2.0"	3000	3000	3000	3000	3000	3000
1.5"	3000	3000	3000	3000	3000	3000
1.0"	3000	3000	3000	3000	3000	3000
0.5"	3000	3000	3000	3000	3000	3000
0"	3000	3000	3000	3000	3000	3000

0.58/0.66 CID

Pulley Ø	2	4	6	8	10	12
Gear pitch Ø	1	2	3	4	5	6
Y Dimension						
2.0"	2250	3000	3000	3000	3000	3000
1.5"	2250	3000	3000	3000	3000	3000
1.0"	2500	3000	3000	3000	3000	3000
0.5"	2500	3000	3000	3000	3000	3000
0"	2750	3000	3000	3000	3000	3000

.84 CID

Pulley Ø	2	4	6	8	10	12
Gear pitch Ø	1	2	3	4	5	6
Y Dimension						
2.0"	1750	2500	3000	3000	3000	3000
1.5"	1750	2750	3000	3000	3000	3000
1.0"	2000	2750	3000	3000	3000	3000
0.5"	2000	3000	3000	3000	3000	3000
0"	2250	3000	3000	3000	3000	3000

1.02 CID

Pulley Ø	2	4	6	8	10	12
Gear pitch Ø	1	2	3	4	5	6
Y Dimension						
2.0"	1250	2000	2250	2500	2750	3000
1.5"	1250	2000	2500	2750	3000	3000
1.0"	1250	2000	2500	2750	3000	3000
0.5"	1500	2250	2500	2750	3000	3000
0"	1500	2250	2750	3000	3000	3000

Series 26 pump Side-load applications

Maximum allowable operating pressures

Ideal positions shown. Side load is acceptable within 90° of either side of the ideal position. Charts are based on 100% slack side tension. Max. speed per catalog. Max. operating pressure shown.

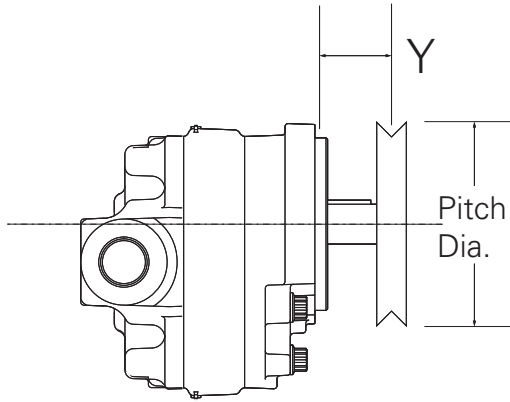

1.20 CID

Pulley Ø	2	4	6	8	10	12
Gear pitch Ø	1	2	3	4	5	6
Y Dimension						
2.0"	N/R	1500	2000	2250	2250	2500
1.5"	N/R	1500	2000	2250	2500	2500
1.0"	N/R	1750	2000	2250	2500	2500
0.5"	1250	1750	2250	2250	2500	2750
0"	1250	1750	2250	2500	2750	3000

1.69 CID

Pulley Ø	2	4	6	8	10	12
Gear pitch Ø	1	2	3	4	5	6
Y Dimension						
2.0"	N/R	N/R	1250	1500	1500	1750
1.5"	N/R	N/R	1250	1500	1500	1750
1.0"	N/R	N/R	1250	1500	1750	1750
0.5"	N/R	1250	1250	1500	1750	1750
0"	N/R	1250	1500	1750	1750	2000

1.37 CID

Pulley Ø	2	4	6	8	10	12
Gear pitch Ø	1	2	3	4	5	6
Y Dimension						
2.0"	N/R	1250	1750	2000	2000	2250
1.5"	N/R	1250	1750	2000	2000	2250
1.0"	N/R	1500	1750	2000	2250	2250
0.5"	N/R	1500	1750	2000	2250	2250
0"	N/R	1500	1750	2000	2250	2500

.148/1.54 CID

Pulley Ø	2	4	6	8	10	12
Gear pitch Ø	1	2	3	4	5	6
Y Dimension						
2.0"	N/R	N/R	1250	1500	1750	2000
1.5"	N/R	1250	1500	1750	1750	2000
1.0"	N/R	1250	1500	1750	2000	2000
0.5"	N/R	1250	1500	1750	2000	2000
0"	N/R	1500	1750	2000	2000	2250

1.77/1.87 CID

Pulley Ø	2	4	6	8	10	12
Gear pitch Ø	1	2	3	4	5	6
Y Dimension						
2.0"	N/R	N/R	N/R	1250	1500	1500
1.5"	N/R	N/R	1250	1250	1500	1500
1.0"	N/R	N/R	1250	1250	1500	1500
0.5"	N/R	N/R	1250	1500	1500	1750
0"	N/R	N/R	1250	1500	1750	1750

Series 26 pump

Load sensing priority valve

The Load Sensing Priority Valve is used with the open loop load sense systems that are typically used in steering and braking circuits. The load sense gear pump provides metered priority flow (CF) on demand.

The excess flow (EF) is available for auxiliary circuits. The response time was selected to insure that the operator will not sense a delay or steering "kick" during transient conditions.

Valve specifications

Rated Pressure	207 BAR (3000PSI)
Rated Inlet Flow	108 L/m (28GPM)
Maximum Controlled Flow (CF)	33 L/m(8.5 GPM)
Bias Pressure	Dynamic - 10 bar (150 PSI) Std. Static - 6.9 bar (100 PSI) Std.
Relief Pressure	34.5-207 bar (500-3000 PSI)
Response Time	70 msec. max. (std. bias spring)

Pump specifications

Displacements	9 Available: 8.2cm ³ /r [1.50 in ³ /r] thru 30.6 cm ³ /r [1.87in ³ /r]
Mounting	SAE 2-Bolt A Mount SAE 2-Bolt B Mount 4-Bolt European Mount (80mm Pilot)

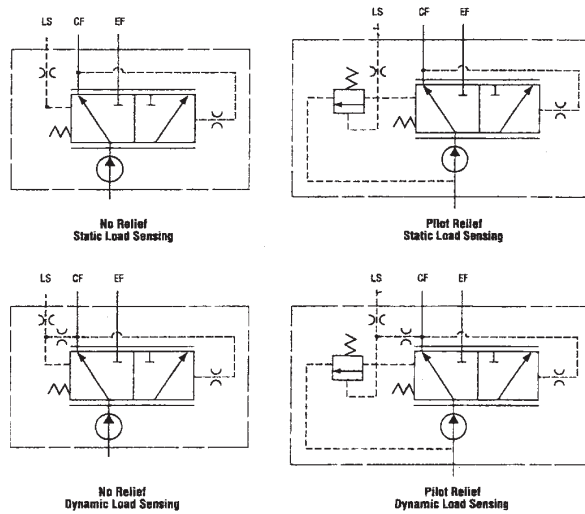
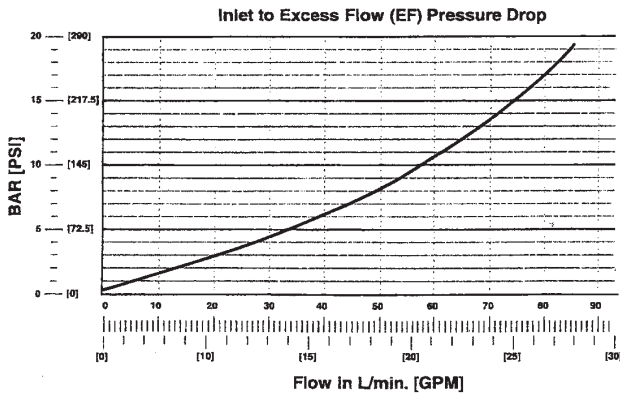

Series 26 motor General specifications

Rotation	Bi-Rotation
Mounting Flange	SAE A 2 Bolt
Max. Continuous Pressure†	210 bar [3000 PSI]*
Max. Intermittent Pressure††	240 bar [3500 PSI]**
Minimum Speed at Continuous Pressure	750 RPM
Maximum Rotating Torque at 0 Pressure	4 Nm [36 lb-in]
Maximum Continuous Operating Temperature	105°C [220°F]
Minimum Continuous Oil Viscosity	5.7 cSt [45 SUS]
Minimum Operating Temperature	-29°C [-20°F]
Maximum Inlet Vacuum at Operating Condition	0,8 bar Abs. [11.6 psi Abs.]
Maximum Thrust Load	50 lbs.
Maximum Seal Pressure	150 PSI, 200 PSI @ 1500 RPM

† Continuous - motor may be run continuously at these ratings.

†† Intermittent - intermittent operation, 10% of every minute.

* 31.8 cm³/rev. [1.94 in³/rev.] displacement max. continuous pressure is 190 bar [2750 PSI].

** 31.8 cm³/rev. [1.94 in³/rev.] displacement max. intermittent pressure is 224 bar [3250 PSI]. For side load limits consult your Eaton representative.

	7,0 [.43]	8,8 [.54]	10,1 [.62]	11,6 [.71]	14,5 [.88]	17,3 [1.06]	20,3 [1.24]
Displacement cm³/r [in³/r]							
Max. Intermittent Pressure bar [PSI]	241 [3495]	241 [3495]	241 [3495]	241 [3495]	241 [3495]	241 [3495]	241 [3495]
Rated Speed (RPM)	3600	3600	3600	3600	3600	3200	3200
Minimum Output Flow at Continuous Rated Speed and Pressure LPM [GPM]	22,2 [5.9]	27,9 [7.4]	32,0 [8.5]	36,7 [9.7]	48,0 [12.7]	50,9 [13.5]	59,8 [15.8]

	23,1 [1.41]	25,2 [1.54]	26,0 [1.59]	28,8 [1.76]	30,3 [1.85]	31,7 [1.93]
Displacement cm³/r [in³/r]						
Max. Intermittent Pressure bar [PSI]	241 [3495]	241 [3495]	241 [3495]	241 [3495]	234 [3393]	224 [3248]
Rated Speed (RPM)	3000	3000	3000	3000	3000	3000
Minimum Output Flow at Continuous Rated Speed and Pressure LPM [GPM]	63,8 [16.8]	69,6 [18.4]	71,8 [19.0]	79,5 [21.0]	83,6 [22.1]	87,5 [23.1]

The performance data in the table above and the following graphs was collected using a mineral base oil with a viscosity of 133 SUS at 49°C [120°F].

Ordering information

Catalog assemblies cross reference

Standard catalog assemblies are built from high production parts and are the most economical pump assemblies available in this series. The standard assembly order number is a preassigned part number and may be used to order the specific standard assembly (see page 27).

Shandong Topkit Construction Machinery Equipment Co., Ltd., is a high-tech company specialized in the manufacturing and supplying for hydraulic pumps, valves, motors, reducers, gearboxes, etc.

We mainly focuses on hydraulic parts for hydraulic excavators, and the products have been serialized. We dedicated on the following three systems and five series products. We specialized in Positive flow system , negative flow system, load sensing control system;

Five series refer to 6-ton products, 8-ton products, 20-ton products, 40-ton products, concrete series products.

Our featured products 20-ton excavator negative flow pump, positive flow pump, positive flow valve, and rotary motor passed the national appraisal in 2012.

In quality control, we passed the ISO2001:2015 quality management system certification in 2022; and we also passed the ISO14001:2015 environmental management system certification in this year. We always persist in the quality control and try best to enhance quality all the time.

In R&D Field, we have a professional team with more than 10 people, of which more than 90% have accumulated more than ten years of hydraulic product technology, and have become the main force for the company to develop new products.

Now our products has exported to dozens of countries, such as Russia, Middle East countries, Asian and African countries. We will continue to develop new products in top quality, and sincerely wish establishing business cooperation with more friends. Thanks

Phone : +86 150 539 47199

whatsapp : +86 150 539 47199

email : george@topkitparts.com