

Medium-Pressure Closed-Circuit Piston Pumps Repair Manual

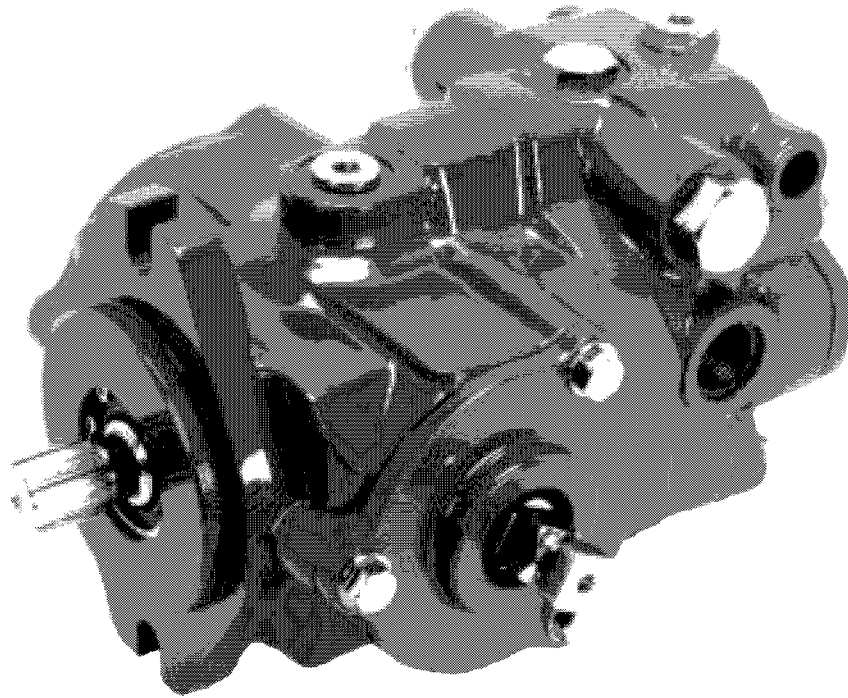

Eaton®
Medium Duty Piston Pump

No. 6-637
January 1998



**Parts and Repair
Information**



Model 70360 Variable Displacement Piston Pump

40,6 cm³/r [2.48 in³/r] or 49,2 cm³/r [3.00 in³/r] Displacements

Manual Controlled

Introduction

Table of Contents

Introduction	2
Identification	3
Tools Required	3
Parts Drawing	4 - 5
Parts List	6 - 14
Main Parts List	6 - 7
Rotating Kit Assembly	8
Cap Screw Locations	8
Relief Valve	9
Backplate Assembly Identification	10 - 11
Charge Pump Adapter Identification	12 - 13
Drive Shaft Identification	14
Repair information	15 - 19
Disassembly	15 - 17
Reassembly	18 - 19
Fault - Logic Troubleshooting	20 - 24
Start-up Procedure	25

Introduction

This manual provides service information for Eaton Models 70360 variable displacement piston pumps. Step by step instructions for the complete disassembly, inspection, and reassembly of the pump are given. The following recommendations should be followed to insure successful repairs.

- Remove the pump from the application.
- Cleanliness is extremely important.
- Clean the port areas thoroughly before disconnecting the hydraulic lines.
- Plug the pump ports and cover the open hydraulic lines immediately after they're disconnected.
- Drain the oil and clean the exterior of the pump before making repairs.
- Wash all metal parts in clean solvent.
- Use compressed air to dry the parts. Do not wipe them dry with paper towels or cloth.
- Compressed air should be filtered and moisture free.
- Always use new seals when reassembling hydraulic pumps.
- Lubricate the new rubber seals with a petroleum jelly (Vaseline®) before installation.
- Torque all bolts over gasketed joints, then repeat the torquing sequence to makeup for gasket compression.
- Verifying the accuracy of pump repairs on an authorized test stand is essential.

Parts Drawing

Pump drawn below is typical of a righthand rotation pump.

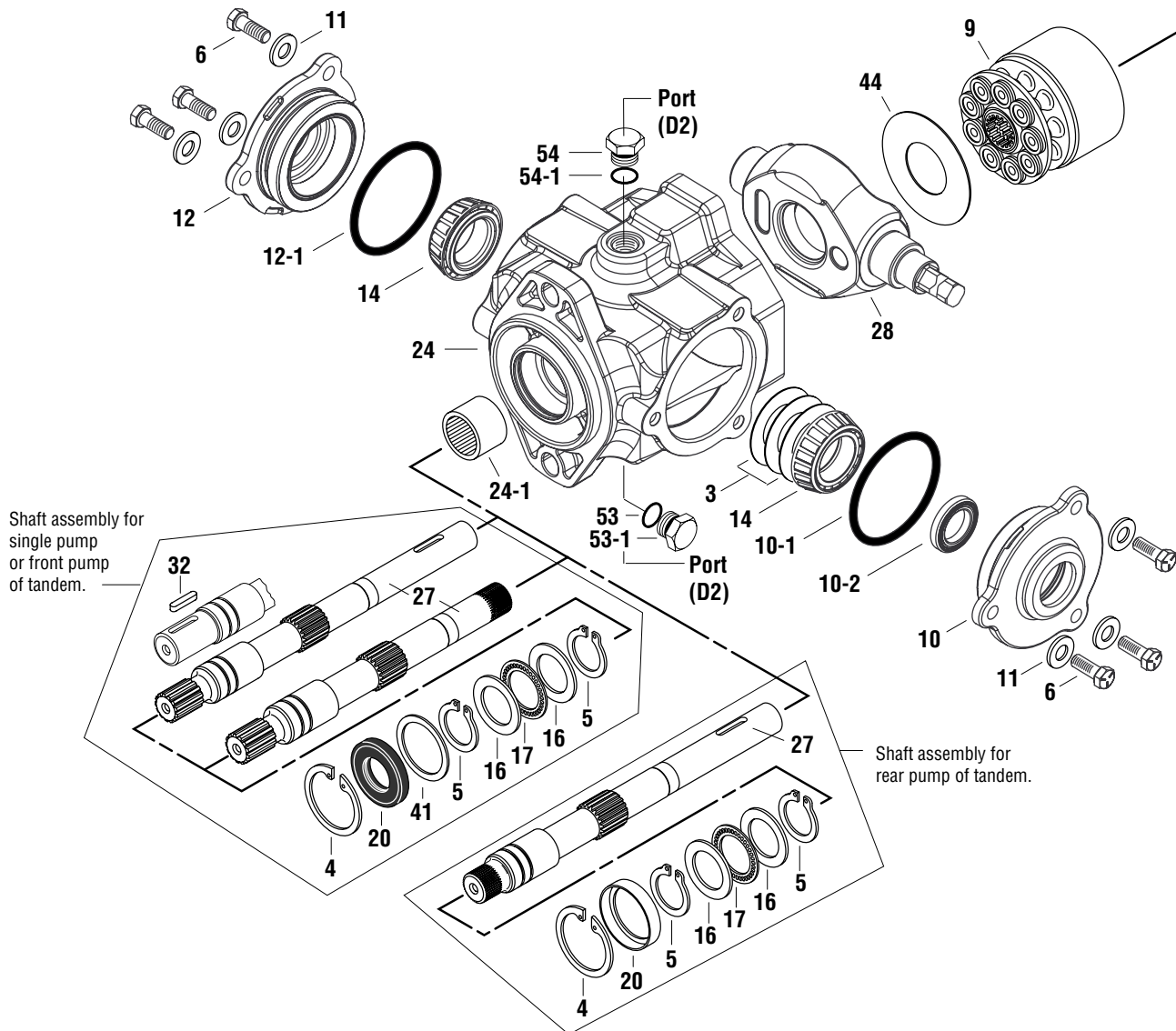

Parts Drawing

Assembly for unit without gerotor charge pump.

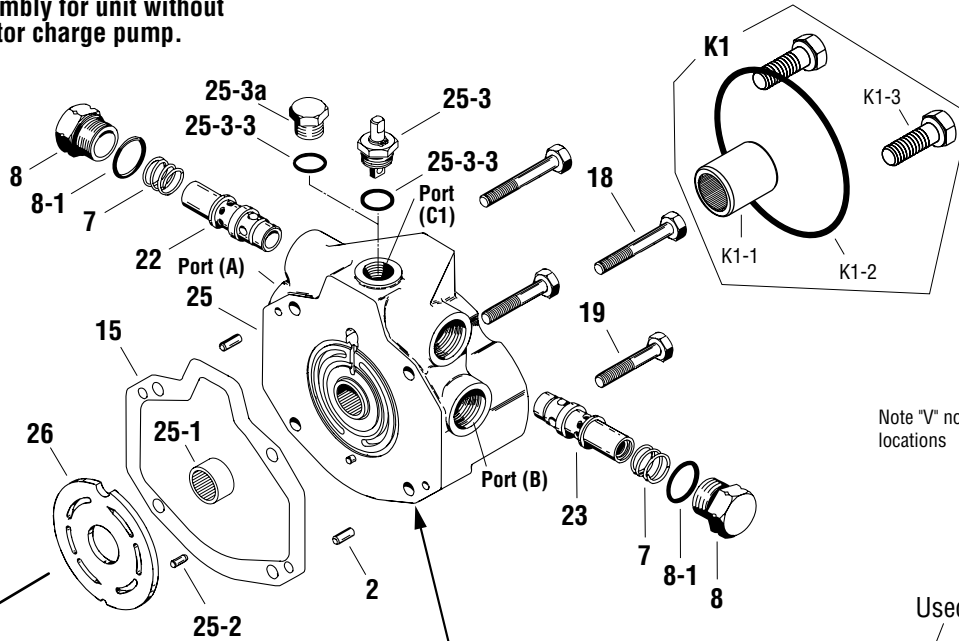

Valve Plate Identification

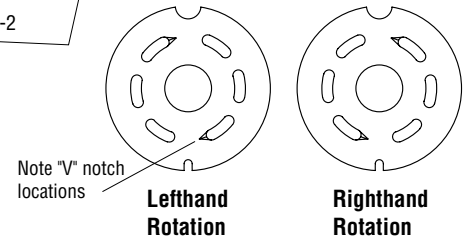

Refer to Backplate Assembly Identification section for additional backplates.

Used in place of Auxiliary pump.

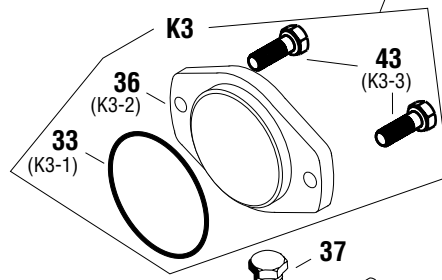

Assembly for single pump or rear pump of tandem.

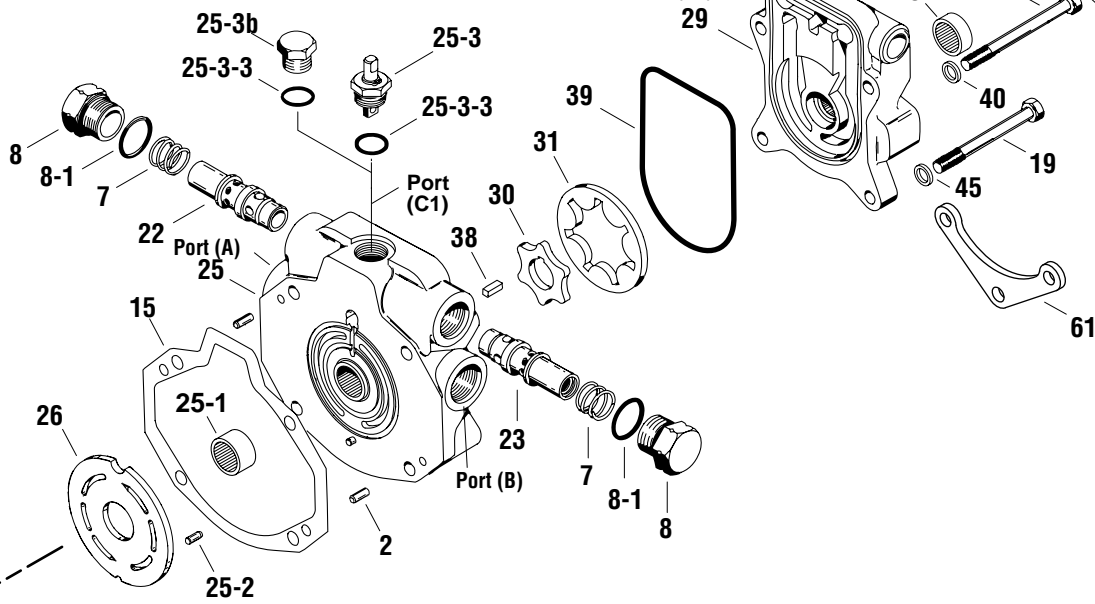

Parts List

Item	Part No.	Qty.	Description
2	16028-404	2	Dowel Pin
3	16322-xxx	A/R	Shims
+ 4	16077-32	1	Retaining Ring
+ 5	16078-18	2	Retaining Ring
6	16032-610	6	Screw
7	17079-2	2	Spring
8	32060-8	2	Plug Assembly
+ 8-1	16015-18-90	2	O-ring, 2,38 mm Dia. x 22,23 mm I.D. [.0937 in. Dia. x .875 in. I.D.]
9	◆	1	Rotating Kit Assembly (parts list on page #8)
10	70360-508	1	Cover Plate SA
+ 10-1	16003-40	1	O-ring, 4,76 mm Dia. x 85,73 mm I.D. [.1875 in. Dia. x 3.375 in. I.D.]
10-2	16253-16	1	Seal, Trunnion Shaft
11	16048-113	6	Washer
12	70360-507	1	Cover Plate SA
+ 12-1	16003-40	1	O-ring, 4,76 mm Dia. x 85,73 mm I.D. [.1875 in. Dia. x 3.375 in. I.D.]
14	16320-122	2	Bearing Cone
+ 15	70412-626	1	Housing Gasket
16	74308-100	2	Thrust Race
17	74308-101	1	Needle Thrust Bearing
18	◆	2	Cap Screws (Locations on page #8)
	16032-622		3/8-16, 57,2 mm [2.25 in.] Long
	16040-640		3/8-16, 101,6 mm [4.0 in.] Long
19	◆	2	Cap Screws (Locations on page #8)
	16032-616		3/8-16, 38,1 mm [1.5 in.] Long
	16032-620		3/8-16, 50,8 mm [2.0 in.] Long
	16032-632		3/8-16, 82,6 mm [3.25 in.] Long
+ 20	16253-18	1	Shaft Seal, Drive
20	16253-218	1	Shaft Seal, Drive (fluorocarbon rubber)
20	70400-620	1	Spacer (Used in rear pump of tandem in place of drive shaft seal.)
22	◆	1	Relief Valve for Port "A" (Identification drawing on page #9)
23	◆	1	Relief Valve for Port "B" (Identification drawing on page #9)
24		1	Housing Assembly
	70360-302	1	with drain port D1 and D2
	70360-309	1	with drain port D1, D2, and D3
24-1	16238-11816	1	Bearing (press fit)
25	◆	1	Backplate Assembly (Identification drawing and parts list on page #10 & #11)
26		1	Valve Plate (Identification drawing on page #5)
	70344-51		Righthand (CW) Rotation
	70344-52		Lefthand (CCW) Rotation
27	◆	1	Drive Shaft (Identification drawing on page #14)
28	◆	1	Camplate
	70360-606	1	Square End Trunnion
29	◆	1	Charge Pump Adaptor (Identification drawing and parts list on page #12 & #13)
30		1	Inner Gerotor
	79004-611		6,9 cm ³ /r [.42 in ³ /r] displacement, 6,35 mm [.25 in.] width
	79004-605		13,8 cm ³ /r [.84 in ³ /r] displacement, 12,7 mm [.5 in.] width
31		1	Outer Gerotor
	79004-612		6,9 cm ³ /r [.42 in ³ /r] displacement, 6,35 mm [.25 in.] width
	79004-606		13,8 cm ³ /r [.84 in ³ /r] displacement, 12,7 mm [.5 in.] width
32		1	Key, Drive Shaft
	16246-516		Used with 25,4 mm[1.00 in] dia. drive shaft.
	24500-619		Used with 22,2 mm [.875 in] dia. drive shaft.
33	16007-14	1	O-ring (In K2 & K3 kit)
34	70411-613	1	Coupler
35	70411-605	1	Mounting Bracket

Parts List

36	70142-600	1	Cover Plate (In K3 kit)
37	16103-108	1	Plug Assembly
+ 37-1	16133-8	1	O-ring, 2,21 mm Dia. x 16,36 mm ID. [.087 in. Dia. x .644 in. ID.]
38	15222-20	1	Key, Gerotor Pump Adapter
+ 39	70342-600	1	Molded O-ring
40	16048-113	2	Washer
41	16048-319	1	Washer
42	16246-523	1	Key, Camplate Trunnion
43	16032-610	2	Cap Screws, Cover Plate (In K3 kit)
44	70300-604	1	Insert, Camplate
45	16048-113	6	Washer
53	16103-308	1	Plug Assembly
+ 53-1	16133-8	1	O-ring, 2,20 mm Dia. x 16,35 mm ID. [.087 in. Dia. x .644 in. ID.]
54	16103-308	1	Plug Assembly
+ 54-1	16133-8	1	O-ring, 2,20 mm Dia. x 16,35 mm ID. [.087 in. Dia. x .644 in. ID.]

Mounting Kits

K1	70342-905	1	Tandem Piston Pump Mounting Kit
K1-1	70411-622	1	41T Coupler, 33,02 mm [1.3 in.] long
K1-2	16007-17	1	O-ring, 1,59 mm Dia. x 101,6 mm ID. [.0625 in. Dia. x 4 in. ID.]
K1-3	16032-812	2	Cap Screws
K2	70442-929	1	Gear Pump Mounting Kit
K2-1	16007-14	1	O-ring, 1,59 mm Dia. x 82,55 mm ID. [.0625 in. Dia. x 3.25 in. ID.]
K2-2	16048-113	1	Washer
K2-3	16032-610	2	Cap Screws
K3	70142-915	1	Cover Plate Kit
K3-1	16007-14	1	O-ring, 1,59 mm Dia. x 82,55 mm ID. [.0625 in. Dia. x 3.25 in. ID.]
K3-2	70142-600	1	Cover Plate
K3-3	16032-610	2	Cap Screws

Seal Repair Kits

•	70360-900	1	Seal Repair Kit for 70360 piston pump. (Order two for tandem pumps)
---	-----------	---	---

Legend

- ◆ Refer to specific item parts list.
- + Common parts to seal repair kits.

Item 9 - Rotating Kit Assembly

Item 18 and 19 - Cap Screw Locations

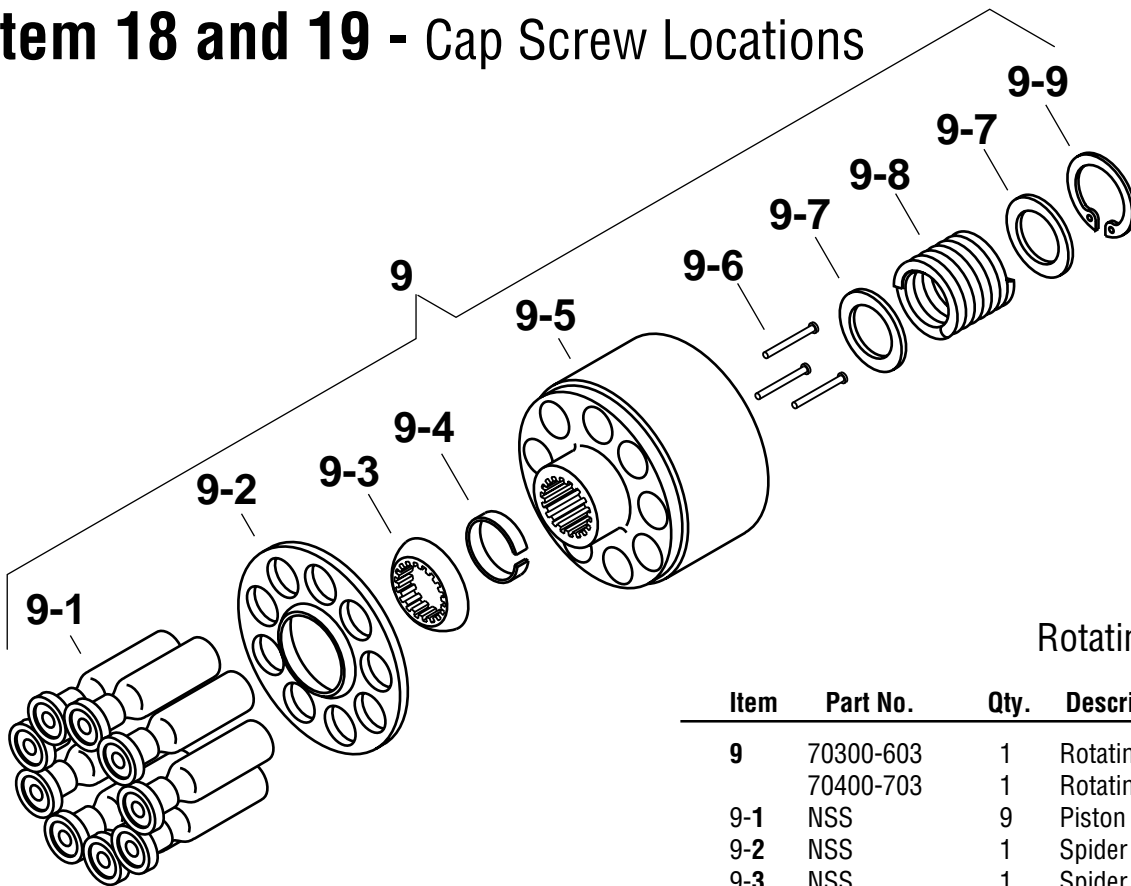

Item 9
Rotating Kit Assembly

Item	Part No.	Qty.	Description
9	70300-603	1	Rotating Kit Assy. 2.48 in ³ /r
	70400-703	1	Rotating Kit Assy. 3.00 in ³ /r
9-1	NSS	9	Piston Assembly
9-2	NSS	1	Spider
9-3	NSS	1	Spider Pivot
9-4	NSS	1	Retainer
9-5	NSS	1	Piston Block
9-6	NSS	3	Pins
9-7	NSS	2	Washer
9-8	NSS	1	Spring
9-9	NSS	1	Retaining Ring
NSS - Not Sold Separately			

Item 18 and 19

Cap Screw Locations

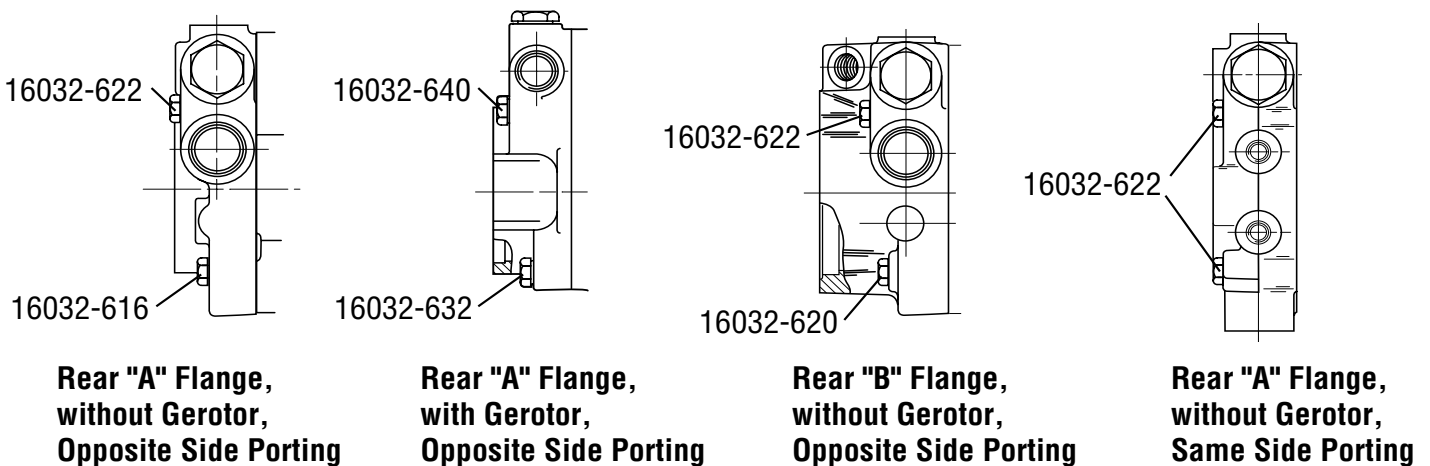

Item 22 or 23 - Relief Valve

Item 22 or 23

Internal Relief Valve Settings Available

Part Number	bar [PSI]
32060-LA	138 [2000]
32060-QA	172 [2500]
32060-UA	207 [3000]
32060-WA	241 [3500]
32060-ZA	276 [4000]
32060-XA	310 [4500]
32060-IA	345 [5000]
70111-518	Seat, Valve

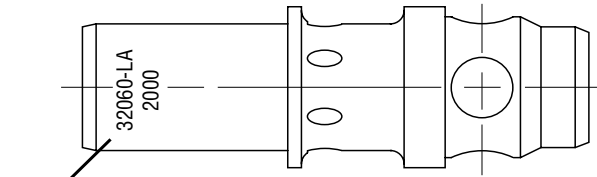

Assembly Number and Pressure Setting

Item 25 - Backplate Assembly Identification

Item 25 - Parts List (Refer to Identification chart and drawings)

Item	Part No.	Qty.	Description
25	See Chart Below		Backplate Assembly
25-1	52200-23	1	Bearing
25-2	16026-610	1	Dowel Pin
25-3	70300-610	1	Bypass Valve Assembly
+ 25-3-1	16078-6	1	Retaining Ring
25-3-2	70300-609	1	Separator Plug
+ 25-3-3	16133-8	1	O-ring, 2,38 mm Dia. x 16,27 mm I.D. [.0937 in. Dia. x .6406 in. I.D.]
25-3-4	70411-502	1	Spreader
+ 25-3-5	16003-7	1	O-ring, 1,59 mm Dia. x 9,53 mm I.D. [.0625 in. Dia. x .375 in. I.D.]
25-3a	16103-108	1	Plug Assembly, Hex
+ 25-3-3	16133-8	1	O-ring, 2,38 mm Dia. x 16,27 mm I.D. [.0937 in. Dia. x .6406 in. I.D.]
25-3b	16103-308	1	Plug Assembly, Internal Hex Socket
+ 25-3-3	16133-8	1	O-ring, 2,38 mm Dia. x 16,27 mm I.D. [.0937 in. Dia. x .6406 in. I.D.]
Legend		+	Common parts to seal repair kits listed.

Item 25 Backplate Assembly Identification (Refer to drawings on page #11)

Description	Assembly Part Number	Aux. Port Machined	C1 Aux. Port Plug	C3 Aux. Port Plug	C1 Aux. Port Bypass Valve	C3 Aux. Port Bypass Valve	C4 Aux. Port Plug
25(a) - Accepts Gerotor Charge Pump	70300-413 70300-426	C1 C1	Item 25-3a		Item 25-3		
25(b) - Rear "A" Mount, Opposite Side Porting	70300-409 70300-415	C1 C1, C3				Item 25-3	
25(c) - Rear "A" Mount, Same Side Porting	70300-403 70300-421 70300-437	C1, C3 C1, C3 C1, C3	Item 25-3a Item 25-3b	Item 25-3b			
25(d) - Rear "B" Mount, Opposite Side Porting	Horizontal 70300-407 70300-411 70300-439 Vertical 70360-413	C1 C1, C4 C1, C4 C1, C4	Item 25-3a Item 25-3a		Item 25-3		
25(e) - Rear "B" Mount, Same Side Porting	Horizontal 70300-401 70300-418 Vertical 70360-411	C1, C4 C1, C4 C1, C4	Item 25-3a Item 25-3a				Item 25-3a

Item 25 - Backplate Assembly Identification

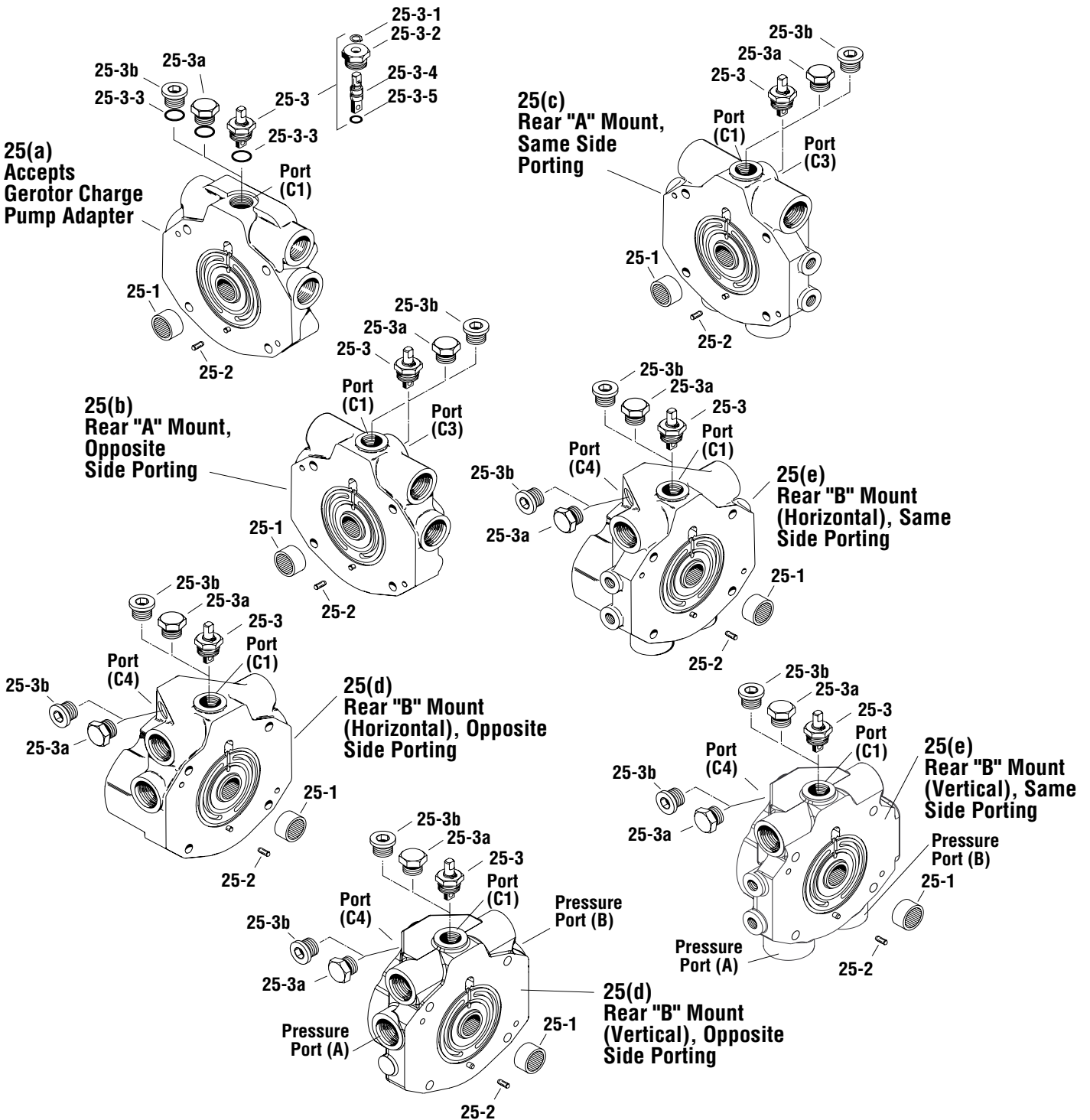

Item 29 - Charge Pump Adapter Assembly Identification

Righthand Rotation

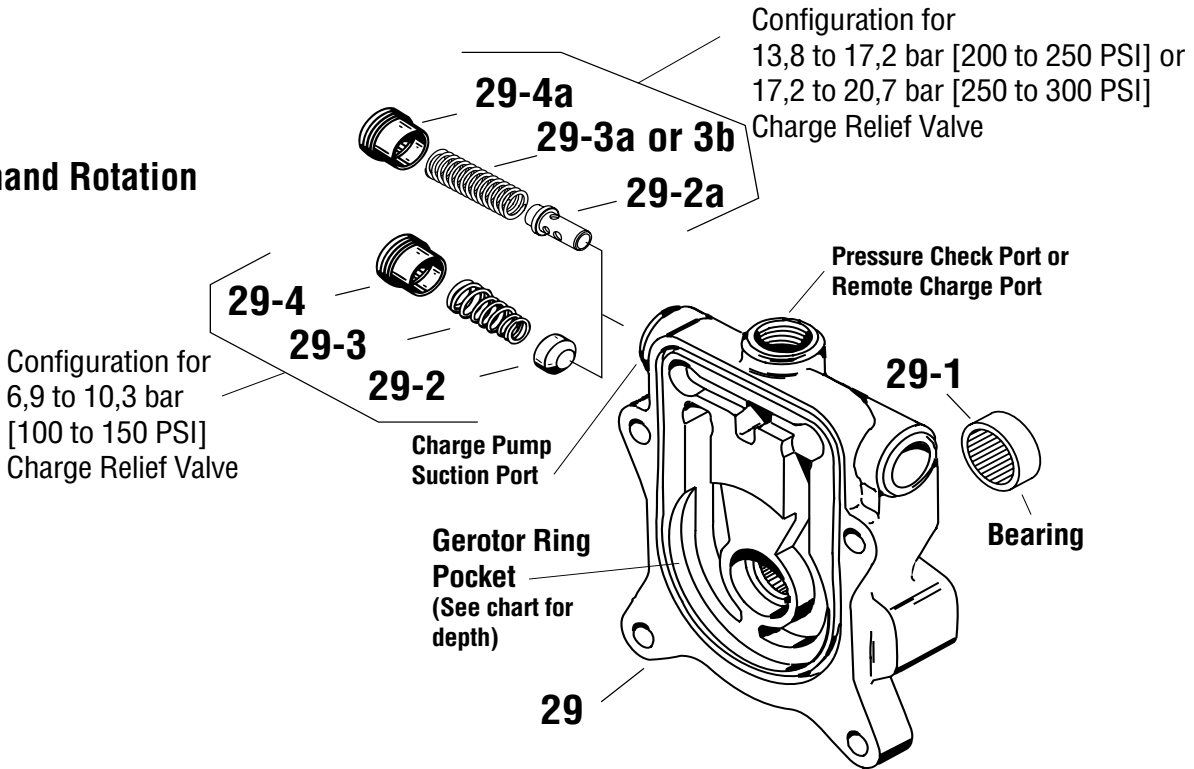

Gerotor Pocket Depth

Displacement cm ³ /r [in ³ /r]	Depth of Pocket mm [in.]
6,9 [.42]	6,35 [.25]
13,8 [.84]	12,7 [.50]

Lefthand Rotation

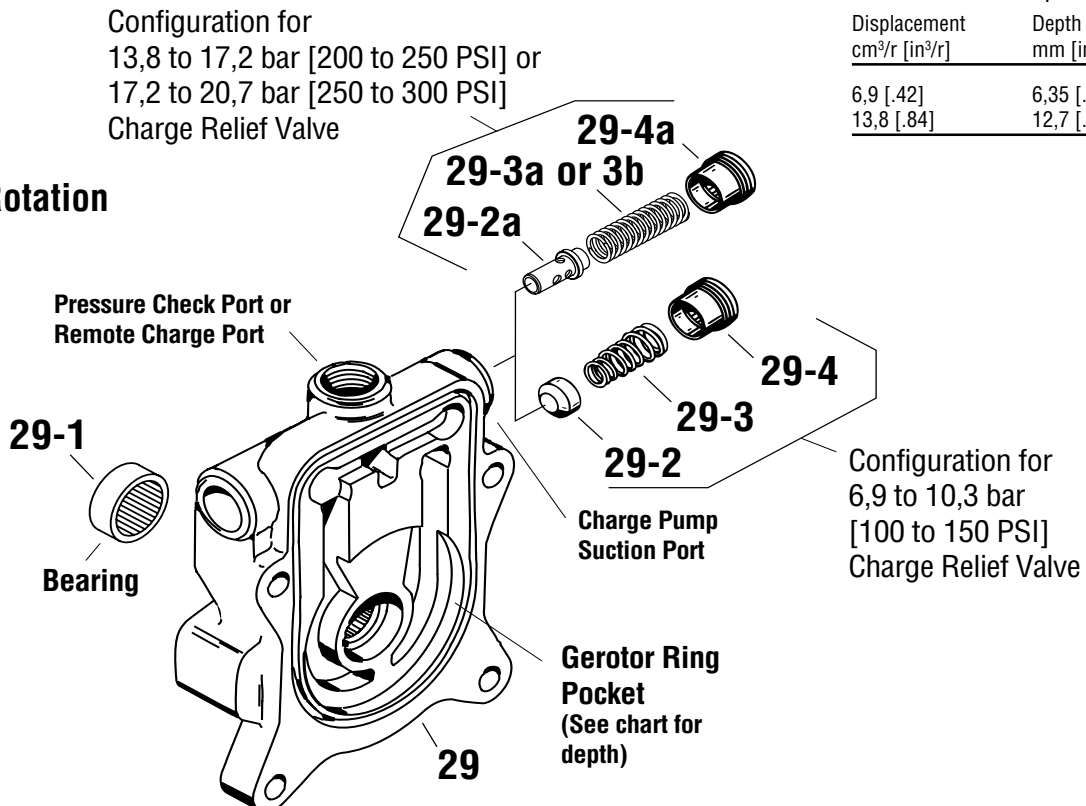

Item 29 - Charge Pump Adapter Assembly

No Charge Relief

Item	Part No.	Qty.	Description	Rotation	Displacement
29	70440-369	1	Assembly, Charge Pump Adapter	Righthand	13,8 cm ³ /r [.84 in ³ /r]
29-1	16239-1148	1	Bearing (press fit)		

6.9 to 10.3 bar [100 to 150 PSI] Charge Relief Setting

Item	Part No.	Qty.	Description	Rotation	Displacement
29	70442-356	1	Assembly, Charge Pump Adapter	Righthand	6,88 cm ³ /r [.42 in ³ /r]
	70442-368	1	Assembly, Charge Pump Adapter	Lefthand	13,8 cm ³ /r [.84 in ³ /r]
	70442-374	1	Assembly, Charge Pump Adapter	Righthand	13,8 cm ³ /r [.84 in ³ /r]
	70442-389	1	Assembly, Charge Pump Adapter	Lefthand	6,88 cm ³ /r [.42 in ³ /r]
29-1	16239-1148	1	Bearing (press fit)		
29-2	70111-507	1	Poppet, Cup		
29-3	17000-48B	1	Spring, Tapered		
29-4	70400-505	1	Spring Retainer		

13.8 to 17.2 bar [200 to 250 PSI] Charge Relief Setting

Item	Part No.	Qty.	Description	Rotation	Displacement
29	70440-388	1	Assembly, Charge Pump Adapter	Lefthand	6,88 cm ³ /r [.42 in ³ /r]
	70440-389	1	Assembly, Charge Pump Adapter	Righthand	6,88 cm ³ /r [.42 in ³ /r]
	70440-385	1	Assembly, Charge Pump Adapter	Righthand	13,8 cm ³ /r [.84 in ³ /r]
29-1	16239-1148	1	Bearing (press fit)		
29-2a	70400-727	1	Poppet, Pin		
29-3a	17056-40	1	Spring, Color "Light Green"		
29-4a	70400-512	1	Spring Retainer		

17.2 to 20.7 bar [250 to 300 PSI] Charge Relief Setting

Item	Part No.	Qty.	Description	Rotation	Displacement
29	70440-381	1	Assembly, Charge Pump Adapter	Righthand	6,88 cm ³ /r [.42 in ³ /r]
	70440-390	1	Assembly, Charge Pump Adapter	Righthand	13,8 cm ³ /r [.84 in ³ /r]
29-1	16239-1148	1	Bearing (press fit)		
29-2a	70400-727	1	Poppet, Pin		
29-3b	17056-41	1	Spring, Color "Pink"		
29-4a	70400-512	1	Spring Retainer		

Item 27 - Drive Shaft Identification

Part Number	Input Drive	Where Used	Output Drive
		Single Pump	9 Tooth Internal
70442-202 [15 Tooth] or 70442-209 [13 Tooth]		Single Pump	9 Tooth Internal
70442-248 [15 Tooth] or 70442-297 [13 Tooth]		Single Pump	9 Tooth Internal
70442-275 [1 in. Keyed] or 70440-200 [7/8 in. Keyed]		Single Pump	9 Tooth Internal
70440-206 [Tapered]		Tandem Front Pump	41 Tooth
70442-228 [15 Tooth]		Tandem Front Pump	41 Tooth
70442-232 [Tapered]		Tandem Middle Pump	41 Tooth
70440-203 [41 Tooth]		Tandem Rear Pump	9 Tooth Internal
70442-229 [41 Tooth]		Tandem Rear Pump	9 Tooth Internal
70442-299 [41 Tooth]			

Repair Information

Disassembly

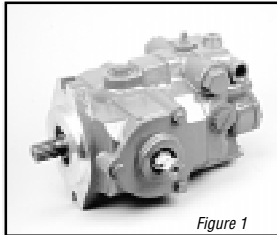

Figure 1

The following disassembly procedure applies to a single pump with or without gear pump. The repair procedure for tandem pumps, once they are separated, is basically the same. The basic configuration differences between a single and tandem pumps are the backplates, pump shafts and housing assemblies. In most

cases, only the rear pump of tandem units contain a charge pump, which is common to both the front and rear pump. The rear tandem pump does not incorporate a shaft seal.

Thoroughly clean the Eaton Model 70360 or 78362 variable displacement pump before any repairs are attempted. When working on tandem pumps, separate the front and rear pumps first.

1 Support the pump with the input shaft down. Use a 9/16 in. socket or end wrench to remove the pump adapter cover plate or gear pump. (See Figure 2)



Figure 2

2 Use a pick or similar tool to remove the adapter cover plate or gear pump o-ring. (See Figure 3)

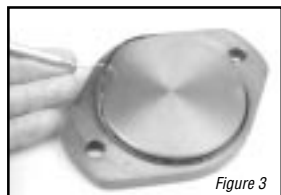

Figure 3

3 Use a 7/16 in. Allen wrench or bit socket remover to remove the charge pressure relief valve spring retainer from the pump adaptor assembly. (See Figure 4)



Figure 4

4 Use a pencil magnet or similar tool to carefully remove the charge pressure spring and poppet from the pump adaptor assembly. (See Figure 5) Use caution not to drop the charge pump poppet into the pump adaptor assembly.



Figure 5

5 The charge pressure relief valve and poppet may be of the standard or high pressure type. The (6.9 to 10.3 bar [100 to 150 PSI]) standard spring and poppet are shown on the bottom and the optional high pressure (13.7 to 20.7 bar [200 to 300 PSI]) spring and poppet is shown on the top.

The same charge pressure relief valve spring retainer is used

with either the standard or high pressure. (See Figure 6)

6 Use a 7/8 in. socket or end wrench to remove the optional bypass valve assembly from the backplate. (See Figure 7)

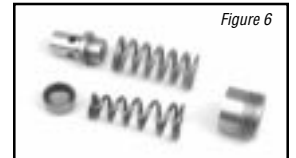

Figure 6

7 The internal seal may be replaced by first removing the small retaining ring on the end of the bypass valve. Remove and replace the o-rings. (See Figure 8)

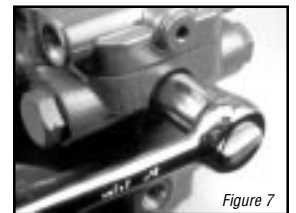

Figure 7

8 Use a 1-1/16 in. socket or end wrench to remove the two high pressure relief valves from the pumps backplate assembly. (See Figure 9) Each system relief valve assembly is identified by both its part number and relief valve setting as shown on page 9.

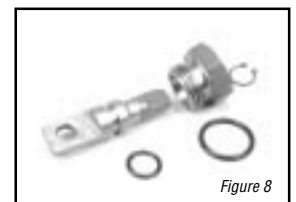

Figure 8

9 Firmly support the pump assembly. Use a 9/16 in. socket or end wrench to remove the four cap screws retaining the charge pump adapter assembly.



Figure 9

10 With the cap screws removed, remove the charge pump adaptor assembly from the backplate. (See Figure 11)



Figure 10

Note: The front pump assemblies do not have charge pump adapter assemblies.

11 Turn the adapter assembly over. Use an o-ring pick or similar tool remove the o-ring seal. (See Figure 12)

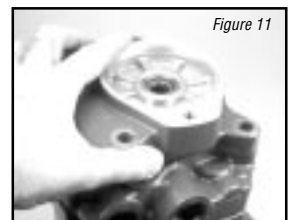

Figure 11

12 Inspect the gerotor pocket and needle bearing located in the charge pump adapter. The needles in the needle bearing must remain intact in the bearing cage.



Figure 12

13 When the needle bearing assembly is replaced, the numbered end of the bearing must face toward the flange side of the adapter to the dimension as shown. (See Figure 13)

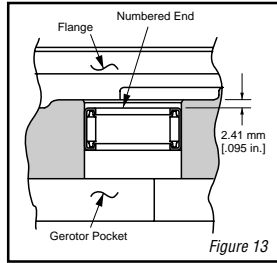

14 With the charge pump adapter removed, remove the charge pump assemblies outer and inner gerotor ring. Next, remove the small drive key from the pump shaft. (See Figure 14 and 15)



15 Charge pumps are available in two different displacements Charge pump displacements are based on the thickness of the gerotor assembly and the depth of the pocket located in the charge pump adapter. To determine the displacement, refer to the table below.

Gerotor Pocket Depth

Displacement cm ³ /r [in ³ /r]	Depth of Pocket mm [in.]
6.9 [.42]	6.35 [.25]
13.8 [.84]	12.7 [.50]

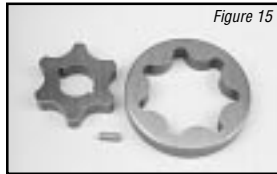

16 To separate the backplate assembly from the dowel pins in the pump housing assembly, insert two screwdrivers between backplate and housing assembly and pry upward. (See Figure 16)



17 After separation, remove the backplate from the housing assembly.

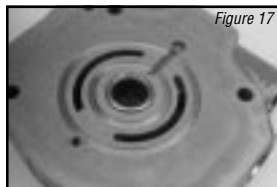

18 Turn the backplate assembly over and inspect the needle bearing. The needles in the needle bearing must remain intact in the bearing cage. (See Figure 17)

19 When the needle bearing assembly is replaced, the numbered end of the bearing must face the valve plate side of the backplate to the dimension as shown. (See Figure 18)

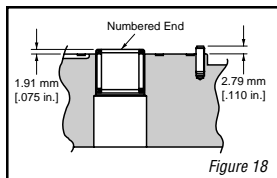

20 With the backplate removed, remove the gasket from the pump housing assembly and discard. (See Figure 19)



21 Remove the valve plate from the piston block assembly. Note: This valve plate may have stuck to the backplate assembly that was just previously removed.

22 Valveplate directional rotation (CW or CCW) is identified by the location of the metering slots located on the face of the valve plates. Pump input rotation should always turn into the metering slots. (See Figure 20) A clockwise valve plate is shown on the left and a counter clockwise valveplate is on the right.

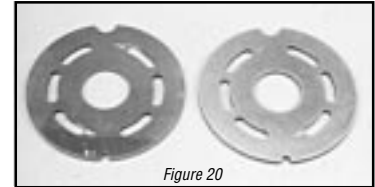

Note: Whenever pump input rotation is changed, the valve plate must be replaced along with the desired rotation charge pump adapter.

23 Remove the rotating kit assembly by carefully retaining it in the housing assembly. Lift the housing and rotating kit assembly and turn over assemblies allowing the rotating kit assembly to slide down the input shaft and out of the pump housing.

24 The model 70360 variable displacement pumps are available in two different displacements. The 40,6 cm³/r ~ [2.48 in³/r] rotating kit assembly is shown below on the left. The 49,2 cm³/r [3.00 in³/r] rotating kit assembly is shown below on the right. The 49,2 cm³/r [3.00 in³/r] rotating assembly is easily identified by having larger pistons and cutouts in the spider. (See Figure 21)

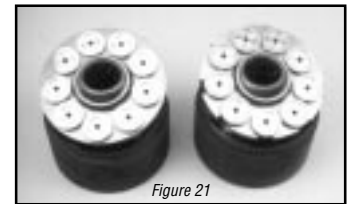

25 With the rotating kit assembly removed, remove the piston assemblies, spider and spider pivot from the piston barrel. (See Figure 22)



26 Inspect the piston assemblies, spider, spider pivot and piston block. The piston block assembly usually requires no further disassembly unless the pins or block spring are damaged.

27 When any excessive wear or scratches are noted on the face of the piston block, the block assembly must be replaced. (See Figure 23)

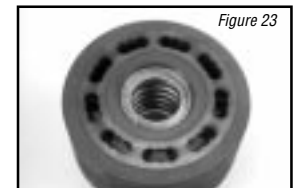

DO NOT LAP THE FACE OF PISTON BLOCK ASSEMBLY.

Repair Information

28 To remove the input shaft assembly, use a pair of internal snap ring pliers and remove the shaft seal retaining ring from the housing assembly. (See Figure 24)

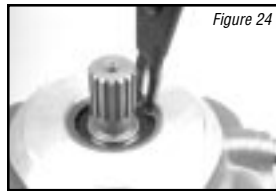

29 With the retaining ring removed, use a small press to press the shaft seal and input shaft assembly from the housing assembly. (See Figure 25)



30 With the input shaft assembly removed, disassemble the assembly for inspection by removing the shaft seal, washer, retaining ring thrust washers and bearing. (See Figure 26)



Note: The rear pump on tandem units uses a spacer in place of shaft seals.

31 To remove the camplate from the housing assembly, use a 9/16 in. socket or end wrench and remove the three cap screws retaining the trunnion coverplate assembly. Start at the cover plate with trunnion controller first. (See Figure 27)

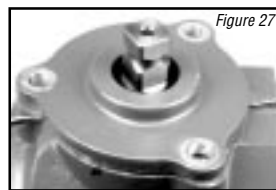

32 With the retaining cap screws removed, insert two small screwdrivers in the notches located in the cover plate assembly and pry upward.

33 Remove the tapered roller bearing from the cam plate. (See Figure 28)



Note: In most cases this tapered roller bearing is a slip-fit on the camplate.

34 With the tapered bearing removed, remove the shims from the camplate. (See Figure 29) Use caution not to misplace or lose these shims. Note: These shims may vary in thickness and are used to adjust camplate end play.



35 Reposition the pump assembly to remove opposite cover plate. Repeat steps 31 through 33.

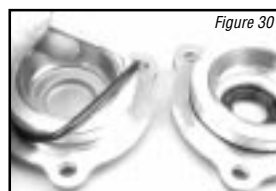

36 Use an o-ring pick or similar tool remove the o-ring seals from the two cover plates. (See Figure 30)

37 To remove the control side cover plate lip seal, use a small press and press the lip seal inward. (See Figure 31)



38 With the camplate bearings removed, slide the camplate toward the control side and lift it from the pump housing. (See Figure 32)

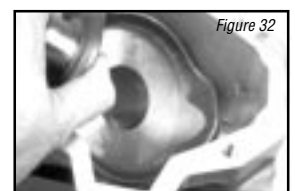

Note: The camplate control shaft will fit out either side of the pump housing. Be sure to note on which side of the housing the control shaft protrudes before removing camplate from housing for correct reassembly orientation.

39 Remove the thrust plate from the camplate. The thrust plate is reversible and either side may face the camplate. (See Figure 33)



40 Inspect the housing assemblies front needle bearing. If the needles remain in their cage and move freely, replacement usually is not required. (See Figure 34)

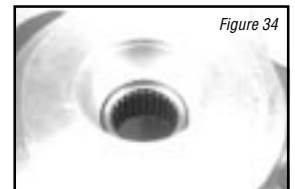

41 When the needle bearing is replaced, the numbered end of the needle bearing must face away from the housing and pressed to the dimension as shown. (See Figure 35)

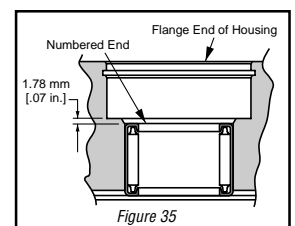

Repair Information

Reassembly

1 Before reassembling the pump, replace all worn and damaged parts, assemblies, seals and o-rings. Lubricate the seals and o-rings with petroleum jelly to help retain them during reassembly and to provide lubrication to the input and control shaft seals. Lubricate all finished part surfaces freely with clean hydraulic fluid to help provide start up lubrication between all rotating parts.

2 To reassemble the camplate into the pump housing, tilt the camplate slightly and install the control side of the camplate through the previously noted or marked side of the housing assembly. (See Figure 36)

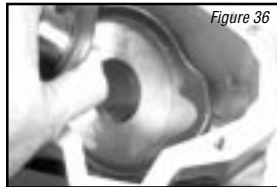

3 With the camplate installed, lubricate and install the tapered bearing on the non-control arm side of the camplate. (See Figure 37)



4 Lubricate and install the o-ring seal on trunnion cover. (See Figure 38)



5 Install the trunnion cover over bearing and on pump housing. Install the three cap screws and torque to 40,7 Nm [30 ft. lbs.]. (See Figure 39)

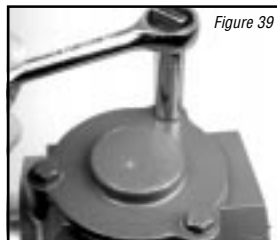

6 Shims are used to adjust the camplate's tapered bearings preload. The shims used may be thick, thin or both. When repairing, start with the same thickness of shims as those removed then add or delete to obtain the proper bearing preload. (See Figure 40)



7 Install the shims on the control arm side of the camplate. (See Figure 41)

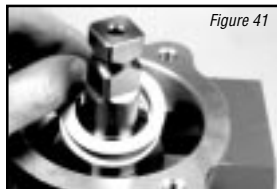

8 With the shims installed, lubricate and install the tapered bearing on the control arm side of the camplate. (See Figure 42)



9 Lubricate and install the control arm shaft seal into the control arm trunnion cover. Install with the lip of the seal facing upward or to the inside of the pump. (See Figure 43)



10 Lubricate and install the o-ring seal on the control arm trunnion cover. (See Figure 44)



11 Install the trunnion cover over the control shaft and into the pump housing. Install the three retaining cap screws and torque to 40,7 Nm [30 ft. lbs.]. (See Figure 45)



12 Using your fingers, tilt the camplate back and forth to check the trunnion bearing preload. Proper preload is achieved when the camplate has a very slight tilting resistance. The camplate must not have any or very little side clearance.

13 Reassemble the input shaft assembly by installing the thrust washer, thrust bearing, second thrust washer, retaining ring, washer and shaft seal. (See Figure 46)



Note: The lip of the shaft seal must point toward the center of the input shaft.

14 Install the input shaft assembly into the housing assembly. Push the shaft seal in just far enough so you can start the shaft seal retaining ring.



15 Use a pair of snap ring pliers to install retaining snap ring into the housing assembly. (See Figure 47)

16 Use a seal driver or similar tool to press or drive the snap ring and seal into the housing assembly. (See Figure 48)



CAUTION! Press or drive inward until the snap ring snaps into the snap ring groove located in the pump housing assembly.

Repair Information

17 The thrust plate is reversible. Either side will fit into the camplate. In most cases if any irregularities are noted it is best to replace the thrust plate. (See Figure 49)



18 Lubricate and install the thrustplate over the input shaft assembly and into the camplate. The thrustplate must rest firmly in its pocket located in the camplate.

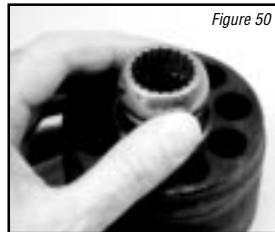

19 Reassemble the rotating kit assembly by first aligning the splines in the pivot with the splines in the block. Install the pivot on the block assembly pins. (See Figure 50)



20 Use a small socket or similar tool to help retain the pivot in the centered position. Lubricate and install the spider and piston assemblies onto the pivot and pistons into the piston block assembly. (See Figure 51)

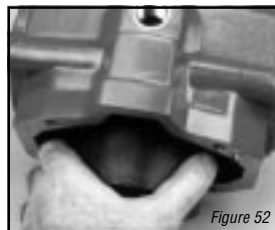

21 Hold the housing assembly in the vertical position then carefully install the rotating kit by first aligning with the splines on the input shaft. With splines aligned, install the rotating kit into the pump housing. (See Figure 52) Use caution to ensure all parts are kept in their proper position.

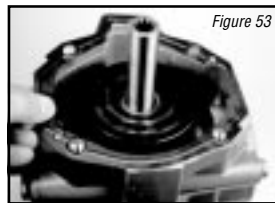

22 With the rotating kit installed, reposition the housing assembly in the input shaft down position and install a new housing gasket. (See Figure 53)

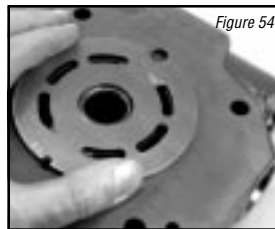

23 Lightly coat the backplate side of the valve plate with petroleum jelly for retention during assembly. Install the valve plate over the needle bearing, aligning the small slot on the outside of the valve plate with the dowel pin in the backplate. (See Figure 54)

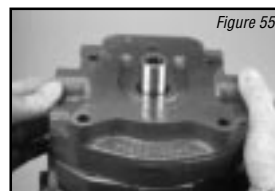

24 Carefully install the backplate assembly by aligning it with the dowel pins located in the pump housing. Use caution not to dislodge the valve plate. (See Figure 55)

25 Lightly coat the charge pump assemblies drive key with petroleum jelly and install it in the drive shaft assembly. (See Figure 56)

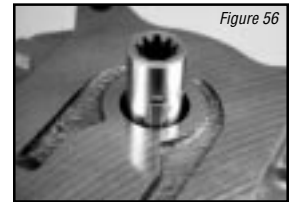

26 Align the keyway of the gerotor's inner ring, then lubricate and install the inner ring and outer ring over the input shaft and onto the backplate assembly. (See Figure 57)

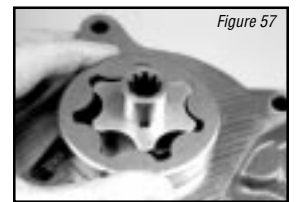

Note: Before installing the charge pump adaptor plate, offset the outer ring of the gerotor as shown.



27 With the gerotor assembly installed, install new o-ring into charge pump adapter plate and place adapter onto backplate over gerotor. Retain with cap screws. Torque cap screws to 52,9 to 56 Nm [39 to 42 ft. lbs.]. (See Figure 58)

28 Install the two high pressure relief valves. Torque valves 128,8 to 142,4 Nm [95 to 105 ft. lbs.]. (See Figure 59)



29 Lubricate and reassemble the bypass valve assembly. Install the bypass valve into the backplate. Torque valve to 36,6 to 40,6 Nm [27 to 30 ft. lbs.]. (See Figure 60)



30 Coat the charge pressure poppet with petroleum jelly and place poppet onto spring and install into the adapter plate. (See Figure 61)



31 Install the hollow charge pressure relief valve retainer into the adapter plate. Torque retainer to 6,8 to 9,5 Nm [5 to 7 ft. lbs.].

32 Lubricate and install the o-ring on the cover plate or gear pump. Install the cover plate or gear pump and two cap screws. Torque cap screws to 36,6 to 40 Nm [27 to 31 ft. lbs.].

The Model 70360 or 78362 variable displacement pump is now ready for test and reinstallation.

Fault - Logic Troubleshooting

This fault - logic Troubleshooting guide is a diagnostic aid in locating transmission problems.

Match the transmission symptoms with the problem statements and follow the action steps shown in the box diagrams. This will give help in correcting minor problems eliminating unnecessary machine down time.

Following the fault - logic diagrams are diagram action comments of the action steps shown in the diagrams. Where applicable, the comment number of the statement appears in the action block of the diagrams.

Explanatory Diagram

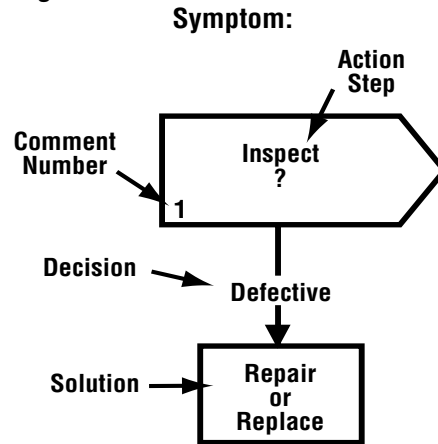

Recommended Gauge Locations

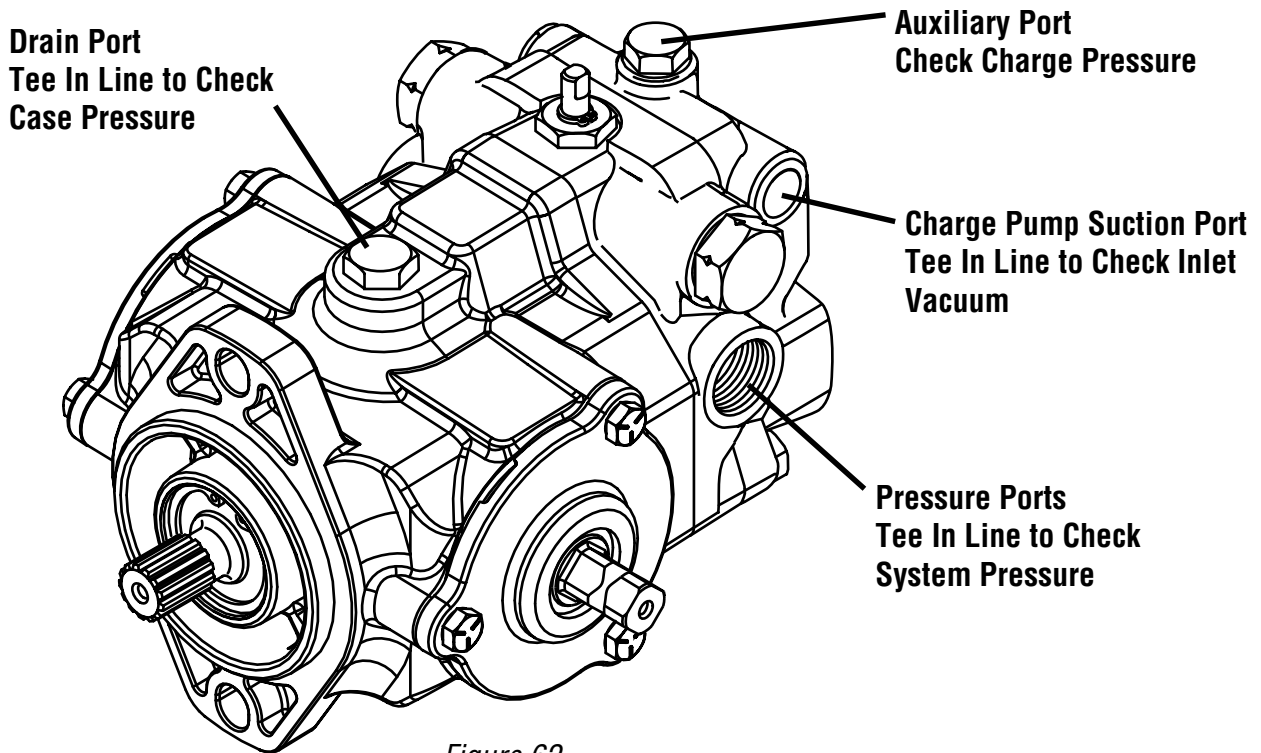

Gauges Recommended

- Inlet vacuum gauge: 2 bar to 1 bar [30 PSI to 30 inHg]
- System pressure gauge: 700 bar [10,000 PSI]
- Charge pressure gauge: 0 to 50 bar [0 to 600 PSI]
- Case pressure gauge: 0 to 25 bar [0 to 300 PSI]

Fault - Logic Troubleshooting

Symptom: Neutral Difficult or Impossible to Find

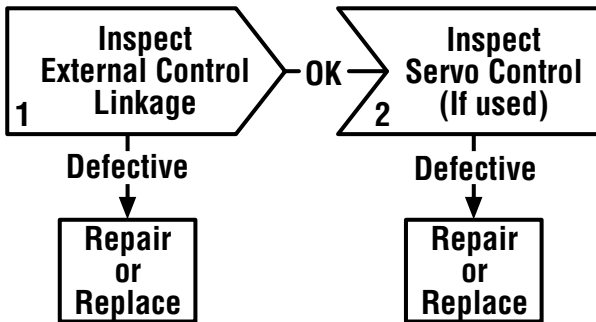

Symptom: System Operating Hot

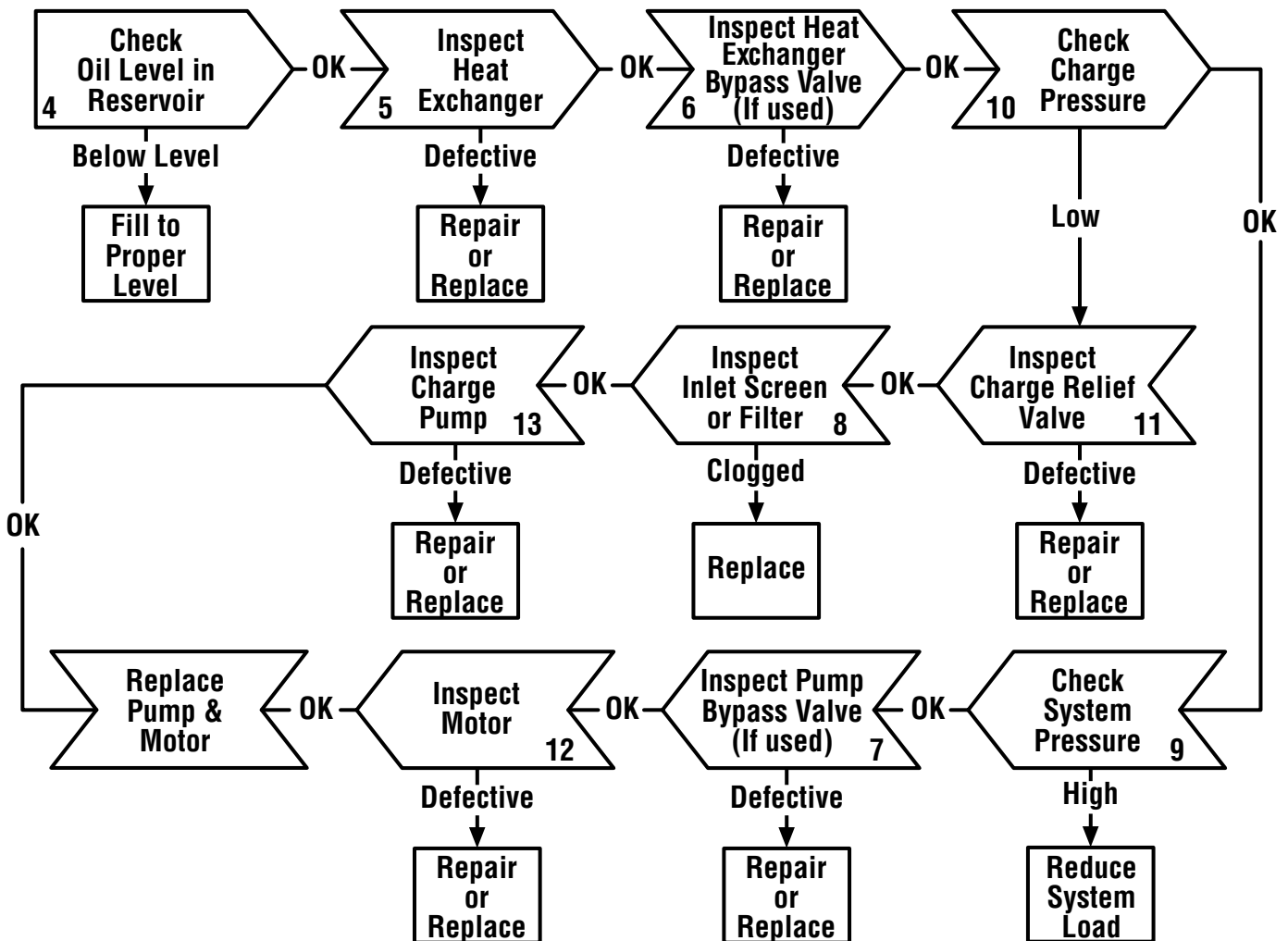

Fault - Logic Troubleshooting

Symptom: Operates in One Direction Only

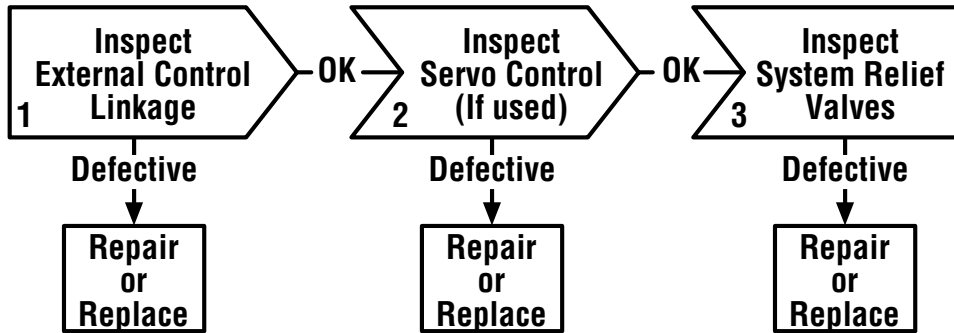

Symptom: System Response Sluggish

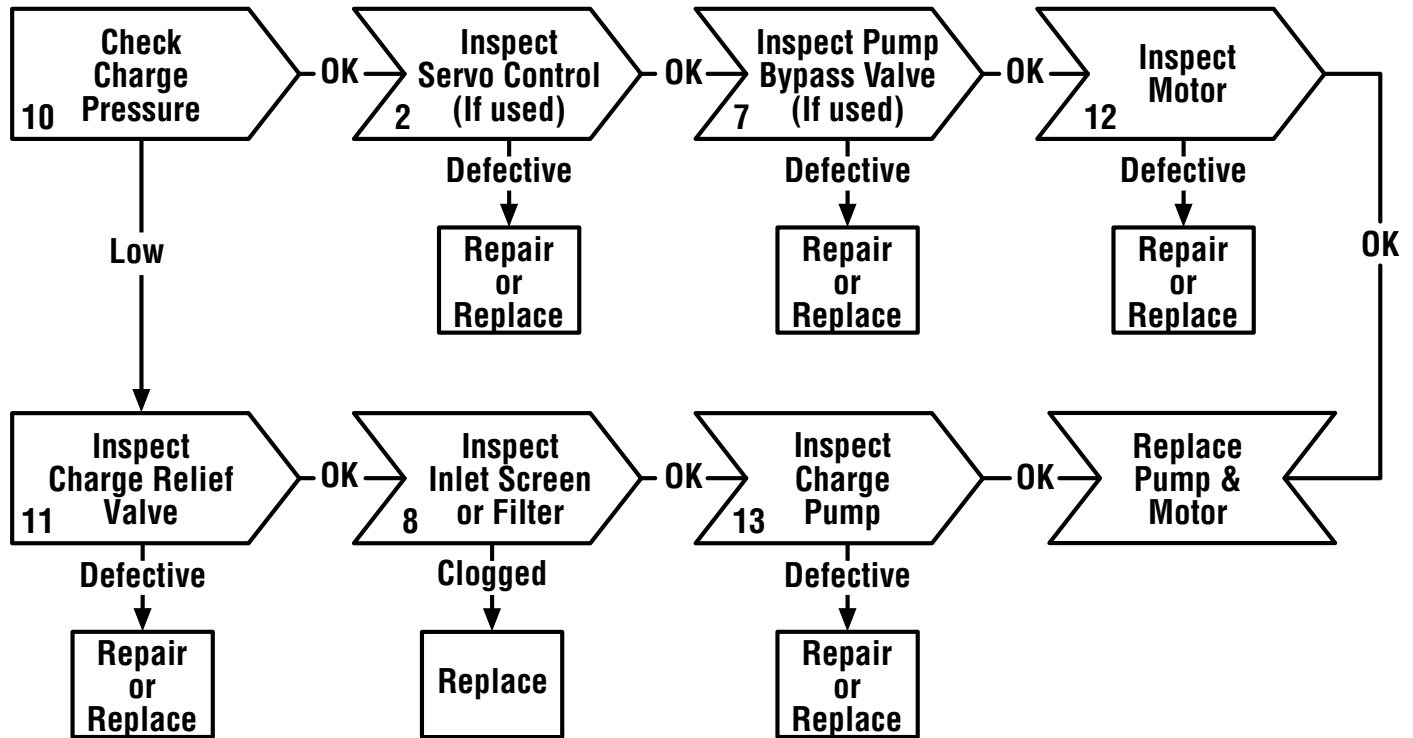

Fault - Logic Troubleshooting

Symptom: System Will Not Operate In Either Direction

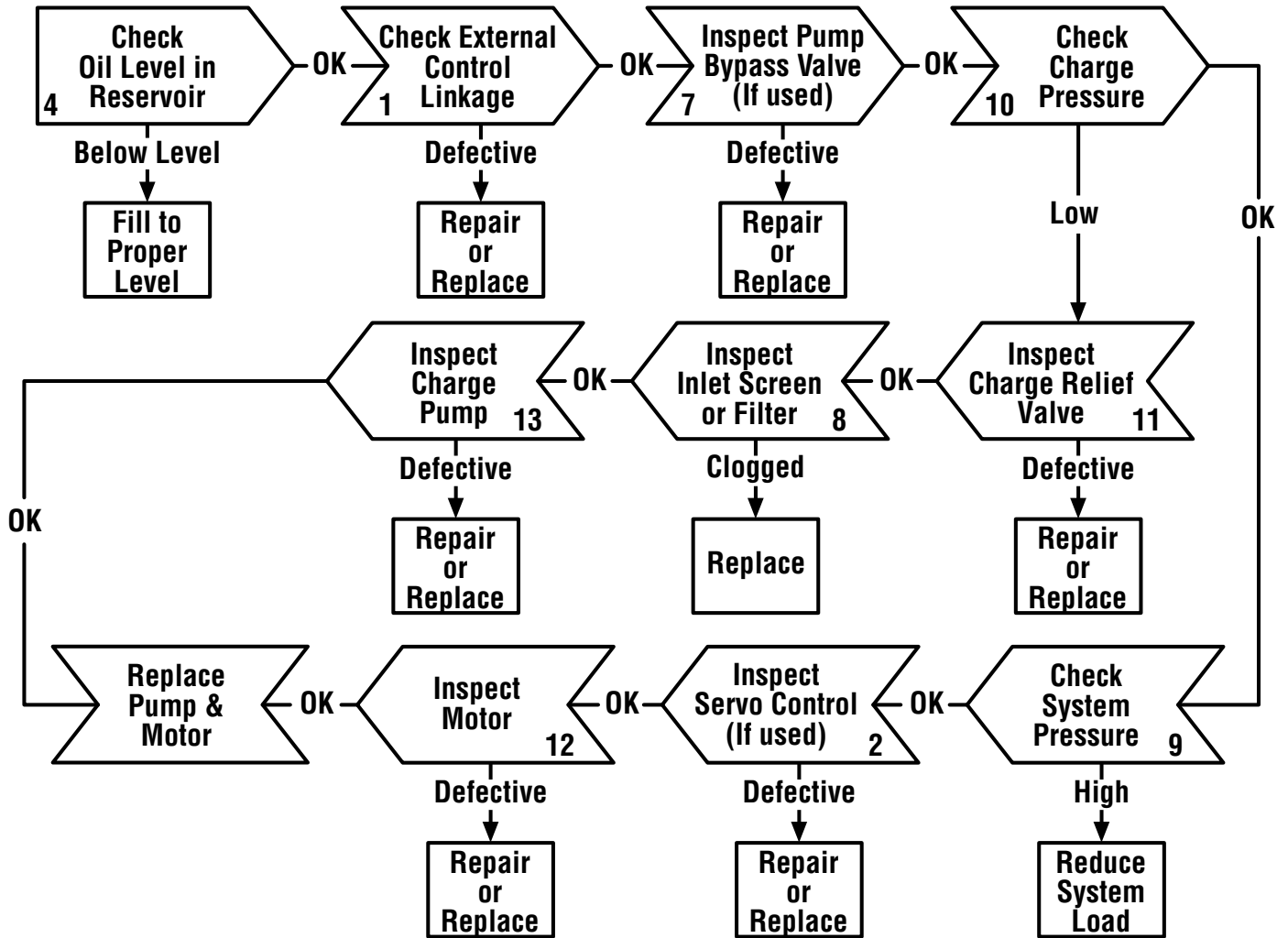

Fault - Logic Troubleshooting

Diagram Action Step Comments

- 1 Inspect External Control Linkage for:**
 - a. misadjustment or disconnection
 - b. binding, bending or breakage
 - c. misadjusted, damaged or broken neutral return spring
- 2 Inspect Servo Control Valve for: (if used)**
 - a. proper inlet pressure
 - b. misadjusted, damaged or broken neutral return spring
 - c. galled or stuck control spool
 - d. galled or stuck servo piston
- 3 Inspect System Relief Valves* for:**
 - a. improper pressure relief setting
 - b. damaged or broken spring
 - c. valve held off seat
 - d. damaged valve seat
- 4 Check Oil Level in Reservoir:**
 - a. consult owner/operators manual for the proper type fluid and level
- 5 Inspect Heat Exchanger for:**
 - a. obstructed air flow (air cooled)
 - b. obstructed water flow (water cooled)
 - c. improper plumbing (inlet to outlet)
 - d. obstructed fluid flow
- 6 Inspect Heat Exchanger Bypass Valve for: (if used)**
 - a. improper pressure adjustment
 - b. stuck or broken valve
- 7 Inspect Pump Bypass Valve for: (if used)**
 - a. held in a partial or full open position
- 8 Inspect Inlet Screen or Filter for:**
 - a. plugged or clogged screen or filter element
 - b. obstructed inlet or outlet
 - c. open inlet to charge pump
- 9 Check System Pressure:**
 - a. See figure 3-1 for location of pressure gauge installation.
 - b. consult owner/operators manual for maximum system relief valve settings
- 10 Check Charge Pressure:**
 - a. See figure 62 for location of pressure gauge installation.
 - b. consult owner/operators manual for maximum charge relief valve settings

- 11 Inspect Charge Relief Valve for:**
 - a. improper charge relief pressure setting *
 - b. damaged or broken spring
 - c. poppet valve held off seat
- 12 Inspect Motor for:**
 - a. disconnected coupling
- 13 Inspect Charge Pump for:**
 - a. broken or missing drive key
 - b. damaged or missing o-ring
 - c. excessive gerotor clearance
 - d. galled or broken gerotor set

*** System/Charge Relief Valve Pressure Settings for Eaton's Variable Displacement Controlled Piston Pumps**

Inlet Vacuum	6 inHg max.
Case Pressure	25 PSI maximum
Charge Pressure	100 to 150 PSI Standard 200 to 250 PSI Optional 250 to 300 PSI Optional
System Pressure	5000 PSI maximum 3000 PSI continuous

The high pressure relief valves are all factory preset and cannot be readjusted.

The pressure setting and assembly number is stamped on each high pressure relief valve cartridge.

Valve Identification Example:

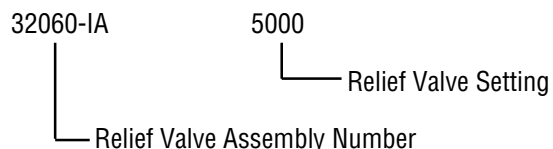

Start-up Procedure

When initially starting a new or rebuilt transmission system, it is extremely important to follow the start-up procedure. It prevents the chance of damaging the unit which might occur if the system was not properly purged of air before start-up.

- 1 After the transmission components have been properly installed, fill the pump housing at least half full with filtered system oil. Connect all hydraulic lines and check to be sure they are tight.
- 2 Install and adjust all control linkage.
- 3 Fill the reservoir with an approved oil that has been filtered through a 10 micron filter. Refer to Eaton Hydraulics Technical Data sheet number 3-401 titled Hydraulic Fluid Recommendations.
- 4 Gasoline or L.P. engines: remove the coil wire and turn the engine over for 15 seconds. Diesel engines: shut off the fuel flow to the injectors and turn the engine over for 15 seconds.
- 5 Replace the coil wire or return the fuel flow to the injectors. Place the transmission unit in the neutral position, start the engine and run it at a low idle. The charge pump should immediately pick up oil and fill the system. If there is no indication of fill in 30 seconds, stop the engine and determine the cause.
- 6 After the system starts to show signs of fill, slowly move pump camplate to a slight cam angle. Continue to operate system slowly with no load on motors until system responds fully.
- 7 Check fluid level in the reservoir and refill if necessary to the proper level with an approved filtered oil.
- 8 Check all line connections for leaks and tighten if necessary.

The machine is now ready to be put into operation.

Frequent filter changes are recommended for the first two changes after placing the machine back into operation. Change the first filter in 3-5 hours and the second in approximately 50 hours. Routinely scheduled filter changes are recommended for maximum life of the hydraulic system.

Shandong Topkit Construction Machinery Equipment Co., Ltd., is a high-tech company specialized in the manufacturing and supplying for hydraulic pumps, valves

, motors, reducers, gearboxes, etc.

We mainly focuses on hydraulic parts for hydraulic excavators, and the products have been serialized. We dedicated on the following three systems and five series products. We specialized in Positive flow system, negative flow system, load sensing

control system;

Five series refer to 6-ton products, 8-ton products, 20-ton products, 40-ton products, concrete series products.

Our featured products 20-ton excavator negative flow pump, positive flow pump, positive flow valve, and rotary motor passed the national appraisal in 2012.

In quality control, we passed the ISO2001:2015 quality management system certification in 2022; and we also passed the ISO14001:2015 environmental management system certification in this year. We always persist in the quality control

and try best to enhance quality all the time.

In R&D Field, we have a professional team with more than 10 people, of which more than 90% have accumulated more than ten years of hydraulic product technology, and have become the main force for the company to develop new products.

Now our products has exported to dozens of countries, such as Russia, Middle East countries, Asian and African countries.

We will continue to develop new products in top quality, and sincerely wish establishing business cooperation with more friends. Thanks

phone:+86 150 539 47199

whatsapp:+86 150 539 47199

email:george@topkitparts.com