

GD5 Series Gear External pump Service Manual



Table of Contents

Contents	
General Introduction	3
Hydraulic System Design Calculations	4
Parts Nomenclature	5
Model Codes	
Single Pump	6
Double Pump	7
Specifications	8
Performance Curves	9-13
Component Dimensions	
Mounting Flange Options	14
Input Shaft Options	15-17
Port Options	18
Installation & Maintenance	19
Changing Rotation	20
Spares	21

General Introduction

Highlights

Eaton Gear Products combine state of the art innovation & manufacturing processes. These products are designed to satisfy global customer requirements for higher pressure, quiet operation, long life & full range of options & features.

GD5 Gear pump is a floating bushing, pressure balanced design with a high strength extruded Aluminum Body, Aluminium or Cast Iron End Cover & Cast Iron Mounting Flange.

The wide choice of Shafts, Flanges & Ports in compliance with all international standards (SAE, DIN, ISO & European). Displacements from 5.1cm³/rev (0.31in³/rev) to 24.0 cm³/rev (1.46 in³/rev). Maximum Pressure up to 210 bar (3046 psi). Maximum speed up to 3000 RPM.

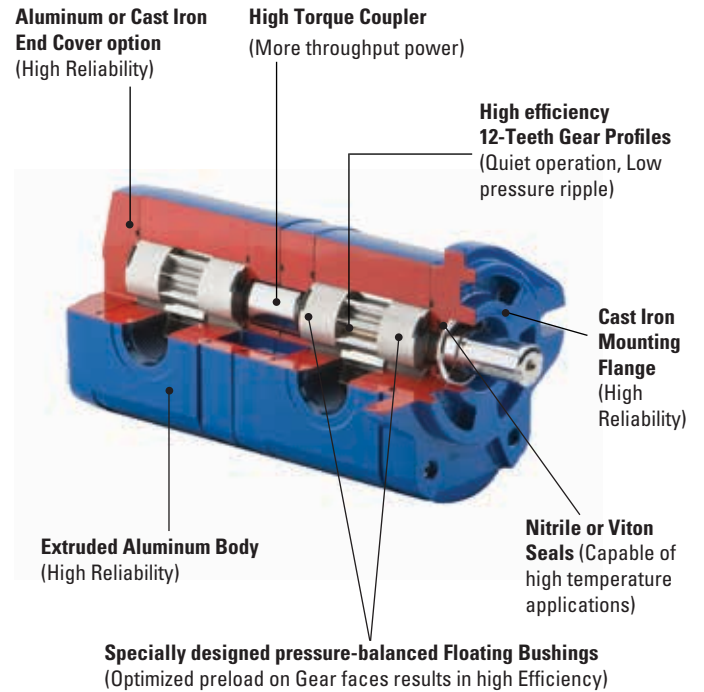

Features

- 12 Teeth, Low noise, Low pressure ripple & High efficiency gear design
- Continuous operating pressures upto 210 bar (3046 psi)
- Maximum operating speed - 3000 RPM
- Displacements from 5.1cm³/rev (0.31in³/rev) to 24.0 cm³/rev (1.46 in³/rev)
- SAE, European, DIN & ISO Flange, Porting styles & Shaft options
- Optional Sectional Sealing for Double pumps
- Built to ISO 9001 Standards

Benefits

- Low noise & Low pressure ripple
- Wide array of features for design flexibility
- Field reversability
- Optimized preload on gear faces resulting in higher efficiencies

Applications

- Tractors & Harvesters
- Machine Tools
- Steering Circuits
- Compactors
- Sweepers
- Rotary & Reel Mowers
- Lift Trucks
- Fan Drive Systems
- Auxiliary Work Circuits

Markets Served

- Agriculture
- Turfcare Equipment
- Construction
- Earthmoving
- Material Handling
- Mining
- Utility Vehicles
- Forestry
- Truck & Bus
- Industrial
- Primary Metals
- Automotive Plant
- Power Generation
- Entertainment

Hydraulic System Design Calculations

Basic Formulae

Output Flow (Q)

$$\text{LPM} = \frac{\text{cm}^3/\text{r} \times \text{RPM}}{1000} \quad \text{GPM} = \frac{\text{in}^3/\text{r} \times \text{RPM}}{231}$$

Input Power (P)

$$\text{kW} = \frac{\text{LPM} \times \text{bar}}{600} \quad \text{hp} = \frac{\text{GPM} \times \text{psi}}{1714}$$

Shaft Torque (M)

$$\text{N-m} = \frac{\text{bar} \times \text{cm}^3/\text{r}}{62.8} \quad \text{lb-in} = \frac{\text{psi} \times \text{in}^3/\text{r}}{6.28}$$

Shaft Speed (n)

$$\text{RPM} = \frac{1000 \times \text{LPM}}{\text{cm}^3/\text{r}} \quad \text{RPM} = \frac{231 \times \text{GPM}}{\text{in}^3/\text{r}}$$

Basic Units

bar	=	10 Newtons/cm ²
GPM	=	Gallons per Minute
hp	=	Horsepower
lb-in	=	Pound Inch
lb-ft	=	Pound Feet
kW	=	Kilowatt
kgf	=	Kilogram-Force
LPM	=	Liters per Minute
N-m	=	Newton Meter
psi	=	Pounds per Square Inch
RPM	=	Revolutions per Minute
cm ³ /r	=	Cubic Centimeter per Revolution
in ³ /r	=	Cubic Inch per Revolution

Output Power (P)

$$\text{kW} = \frac{\text{N-m} \times \text{RPM}}{9549} \quad \text{hp} = \frac{\text{lb-in} \times \text{RPM}}{63025}$$

Efficiency

$$\text{Volumetric } N_v = \frac{\text{Output Flow Actual}}{\text{Output Flow Theoretical}}$$

$$\text{Mechanical } N_m = \frac{\text{Shaft Torque Theoretical}}{\text{Shaft Torque Actual}}$$

$$\text{Total } N_t = N_v \times N_m$$

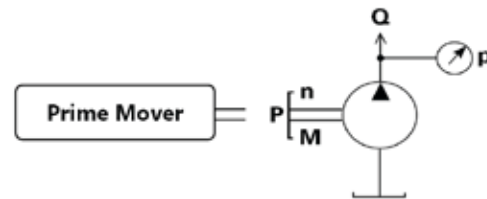

Commonly Used Conversions

To Convert	Into	Multiply by
bar	psi	14.5
cm ³	in ³	0.06102
°C	°F	(°C × 1.8) + 32
Gallons (US)	liters	3.785
kg	lbs	2.205
kW	hp	1.341
liters	US Gallons	0.2642
mm	Inches	0.03937
N-m	lb-in	8.85
N-m	lb-ft	0.7375
°F	°C	(°F - 32) / 1.8
hp	kW	0.7457
Inch	mm	25.4
in ³	cm ³	16.387
lb-in	N-m	0.113
lb-ft	N-m	1.356
lbs	kg	0.4535
psi	bar	0.06895
psi	kgf / cm ²	0.070307

Parts Nomenclature

Single Pump

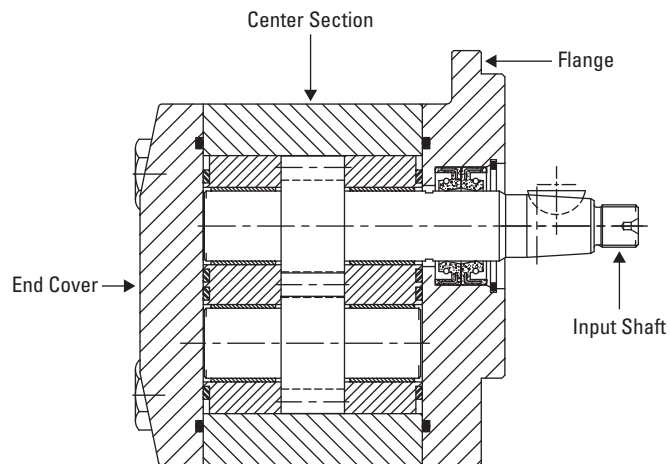

Double Pump with Sectional Sealing (For two separate grades of oil)

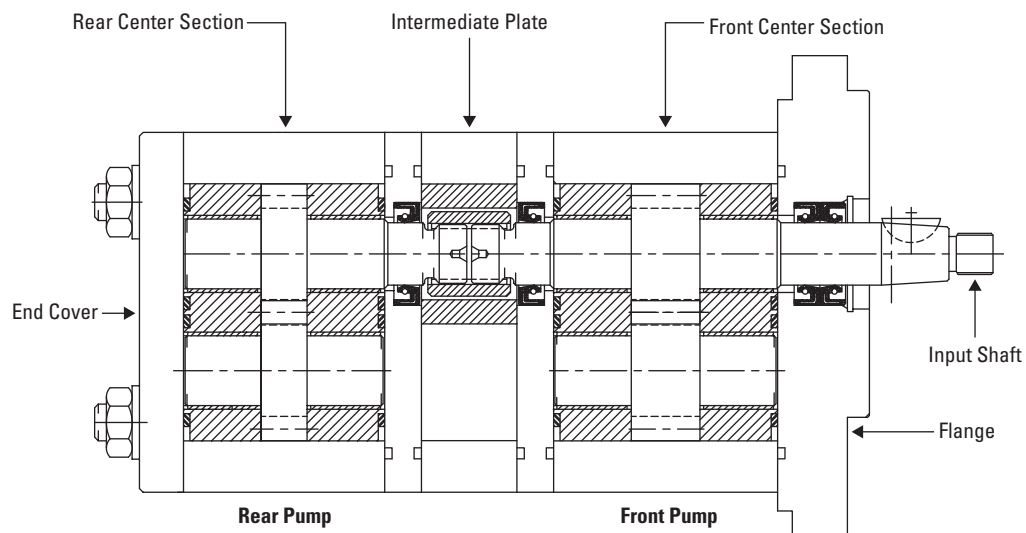

Double Pump (For common oil)

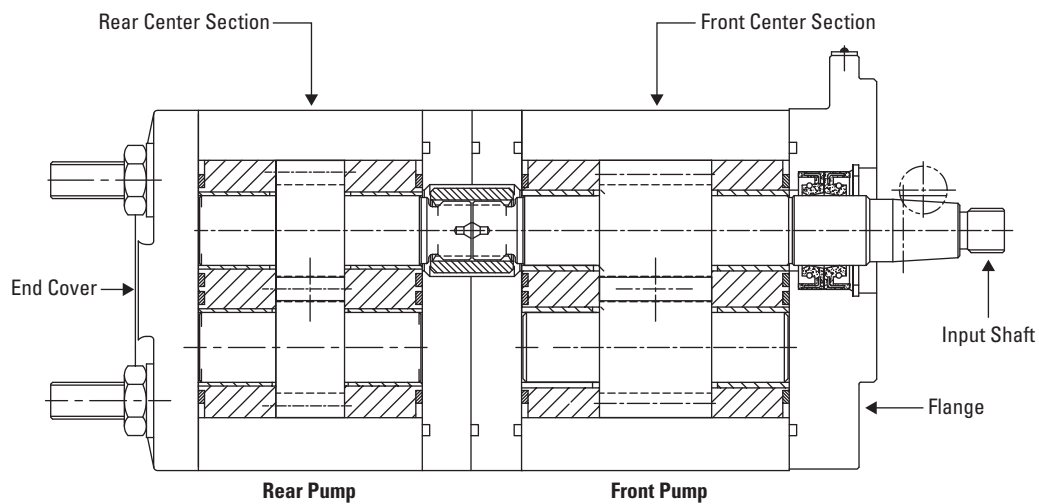

Model Code

Single Pump

The following 23-digit coding system has been developed to identify standard configuration options for the External Single Gear Pump. Use this model code to specify a pump with the desired features. All 23 digits of the code must be present to release a new product number for ordering.

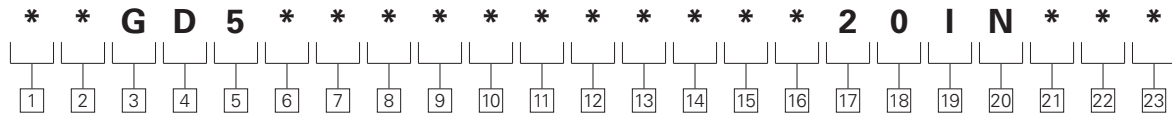

No.	Feature	Code	Feature Description
1 2	Features (Omit for Standard)	F3 F4	Viton Seal Pack Outboard Thrust Bearing
3 4	Type	GD	External Gear Pump
5	Size	5	Frame Size
6 7	Displacement cm ³ /rev (in ³ /rev)	05 06 08 09 11 12 16 18 20 24	5.1 (0.31) 6.0 (0.37) 8.2 (0.50) 9.5 (0.58) 11.0 (0.67) 12.3 (0.75) 16.5 (1.01) 18.0 (1.10) 20.0 (1.22) 24.0 (1.46)
8 9	Mounting Flange	A1 H1 H2 G1	SAE "A" 2 Bolt European Rectangular 4 Bolt German Rectangular 4 Bolt Customized Flange [#]
10 11	Drive Shaft[#]	09 19 20 21 22 24 27 29	Taper 1:8 on dia. with Woodruff Key, External Threads 7/16"-20 UNF Shaft (Shaft ext. 39.7 mm) 14 Teeth, 24/48 DP 30° Involute, Flat Root, Side Fit, 20.0 Min. Full Spline as per ANSI B92.1 (Shaft ext. 32.4 mm) 11 Teeth, 16/32 DP 30° Involute, Flat Root, Side Fit, 20.0 Min. Full Spline as per ANSI B92.1 (Shaft ext. 32.4 mm) Straight Keyed Shaft with ø 17.46, Key width 4.76 mm (Shaft ext. 31.8 mm) Straight Keyed Shaft with ø 19.05, Key width 4.76 mm (Shaft ext. 31.0 mm) Straight Keyed Shaft with ø 15.88, Key width 3.97 mm (Shaft ext. 31.8 mm) 9 Teeth 16/32 DP 30°, Involute, Flat Root, Side Fit, 20.0 Min. Full Spline as per ANSI B92.1 (Shaft ext. 31.5 mm) 28 Teeth, 48/96 DP 45°, Involute, Fillet Root, Side Fit, Class 6, 28.50 Min. Full Spline as per ANSI B92.1 (Shaft Ext 41.2 mm)

No.	Feature	Code	Feature Description
	Port Options		
12 13	Inlet Port		
14 15	Outlet Port		
	European Flanged Ports - 4 Bolts	FA FB	M8 × 1.25, PCD 40.0 & Dia. 19.0 M6 × 1, PCD 30.2 & Dia. 14.0
	German Flanged Ports- 4 Bolts	FO FN FP	M6 × 1, PCD 35.0 & Dia. 15.0 M6 × 1, PCD 40.0 & Dia. 20.0 M6 × 1, PCD 40.0 & Dia. 19.0
	SAE Straight Thread O-Ring Ports	TF TG TJ TM TS	7/8"-14 UNF-2B (SAE#10) 1-5/16"-12 UN-2B (SAE#16) 3/4"-16 UNF-2B (SAE#8) 1-1/16"-12 UN-2B (SAE#12) 1-3/16"-12 UN-2B (SAE#14)
	BSP Straight Thread Ports	TB TC TR	G 1/2" G 3/4" G 3/8"
	Metric Straight Thread Ports (ISO 6149)	TD TE TL	M18 × 1.5-6H M27 × 2.0-6H M22 × 1.5-6H
	Special Ports	FU BT FC	Customized Port [#] Beaded Tube Manifold - Inlet Port
16	Rotation	L R	Left Handed CCW Right Handed CW
17 18	Design Number	20	Design
19 20	Modification (Omit for Standard)	IN	Modification in Product
21 22 23	Series No. (Omit for Standard)	* * *	Modification Series No.

[#] For customized Mounting Flange, Drive Shaft & Port options consult Eaton Representative

Model Code

Double Pump

The following 29-digit coding system has been developed to identify standard configuration options for the External Double Gear Pump. Use this model code to specify a pump with the desired features. All 29 digits of the code must be present to release a new product number for ordering.

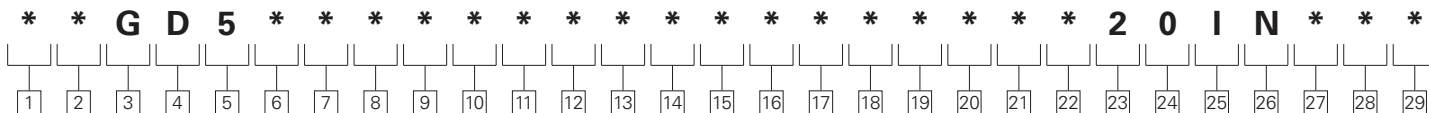

No.	Feature	Code	Feature Description
1 2	Features (Omit for Standard)	F2 F3 F4	Sectional Sealing Viton Seal Pack Outboard Thrust Bearing
3 4	Type	GD	External Gear Pump
5	Size	5	Frame Size
	Displacement[†] cm ³ /rev (in ³ /rev)	05 06	5.1 (0.31) 6.0 (0.37)
6 7	Front Pump Displacement	08 09	8.2 (0.50) 9.5 (0.58)
8 9	Rear Pump Displacement	11 12 16 18 20 24	11.0 (0.67) 12.3 (0.75) 16.5 (1.01) 18.0 (1.10) 20.0 (1.22) 24.0 (1.46)
10 11	Mounting Flange	A1 H1 H2 G1	SAE "A" 2 Bolt European Rectangular 4 Bolt German Rectangular 4 Bolt Customized Flange [#]
12 13	Drive Shaft[#]	09 19 20 21 22 24 27 29	Taper 1:8 on dia. with Woodruff Key, External Threads 7/16"-20 UNF Shaft (Shaft ext. 39.7 mm) 14 Teeth, 24/48 DP 30° Involute, Flat Root, Side Fit, 20.0 Min. Full Spline as per ANSI B92.1 (Shaft ext. 32.4 mm) 11 Teeth, 16/32 DP 30° Involute, Flat Root, Side Fit, 20.0 Min. Full Spline as per ANSI B92.1 (Shaft ext. 32.4 mm) Straight Keyed Shaft with ø 17.46, Key width 4.76 mm (Shaft ext. 31.8 mm) Straight Keyed Shaft with ø 19.05, Key width 4.76 mm (Shaft ext. 31.0 mm) Straight Keyed Shaft with ø 15.88, Key width 3.97 mm (Shaft ext. 31.8 mm) 9 Teeth 16/32 DP 30°, Involute, Flat Root, Side Fit, 20.0 Min. Full Spline as per ANSI B92.1 (Shaft ext. 31.5 mm) 28 Teeth, 48/96 DP 45°, Involute, Fillet Root, Side Fit, Class 6, 28.50 Min. Full Spline as per ANSI B92.1 (Shaft Ext 41.2 mm)

No.	Feature	Code	Feature Description
	Port Options		
14 15	Front Pump Inlet Port		
16 17	Front Pump Outlet Port		
18 19	Rear Pump Inlet Port		
20 21	Rear Pump Outlet Port		
	European Flanged Ports - 4 Bolts	FA FB	M8 × 1.25, PCD 40.0 & Dia.19.0 M6 × 1, PCD 30.2 & Dia.14.0
	German Flanged Ports- 4 Bolts	FO FN FP	M6 × 1, PCD 35.0 & Dia. 15.0 M6 × 1, PCD 40.0 & Dia.20.0 M6 × 1, PCD 40.0 & Dia.19.0
	SAE Straight Thread O-Ring Ports	TF TG TJ TM TS	7/8"-14 UNF-2B (SAE#10) 1-5/16"-12 UN-2B (SAE#16) 3/4"-16 UNF-2B (SAE#8) 1-1/16"-12 UN-2B (SAE#12) 1-3/16"-12 UN-2B (SAE#14)
	BSPP Straight Thread Ports	TB TC TR	G 1/2" G 3/4" G 3/8"
	Metric Straight Thread Ports (ISO 6149)	TD TE TL	M18 × 1.5-6H M27 × 2.0-6H M22 × 1.5-6H
	Special Ports	FU BT FC FD TO	Customized Port [#] Beaded Tube Manifold – Front Pump Inlet Port Manifold – Rear Pump Inlet Port No Port
22	Rotation	L R	Left Handed CCW Right Handed CW
23 24	Design Number	20	Design
25 26	Modification (Omit for Standard)	IN	Modification in Product
27 28 29	Series No. (Omit for Standard)	* * *	Modification Series No.

[#] For customized Mounting Flange, Drive Shaft & Port options consult Eaton Representative

[†] Combination of displacements for Double Pump is decided by torsional strength of Drive Shaft & Coupler. Please consult Eaton Representative while selecting Double Pump displacements

Specifications

Displacement		Rated Pressure		Speed RPM		Minimum Output Flow at 2000 RPM & at Rated Pressure		Approx. Weight
cm ³ /rev	in ³ /rev	bar	psi	min.	max.	LPM	GPM	kg
5.1	0.31	210	3046	700	3000	8.4	2.22	2.7
6.0	0.37	210	3046	700	3000	10.8	2.85	2.8
8.2	0.50	210	3046	700	3000	14.3	3.78	2.9
9.5	0.58	210	3046	700	3000	17.0	4.49	3.0
11.0	0.67	210	3046	700	3000	19.7	5.20	3.2
12.3	0.75	210	3046	700	3000	21.4	5.65	3.3
16.5	1.01	210	3046	700	3000	29.5	7.79	3.4
18.0	1.10	210	3046	700	3000	32.2	8.51	3.5
20.0	1.22	210	3046	700	3000	35.8	9.46	3.7
24.0	1.46	175	2538	700	3000	42.9	11.33	4.0

Technical Data

Rotation	Field Reversible (CW & CCW)
Maximum Axial Load	1000 N [#]
Recommended Fluid Viscosity	16 to 40 cSt (82-185 SUS)
Fluid Operating Temperature Range	-30°C to 100°C [†]
Recommended Cleanliness Requirement (ISO 4406:99)	20/18/13
Inlet Pressure Range	-0.2 bar to 2.0 bar

[#] Applicable only for A1 Flange code with Thrust Bearing. For other options consult Eaton representative

[†] Viton seals available for higher temperatures up to 120°C

Performance Curves

5.1cc

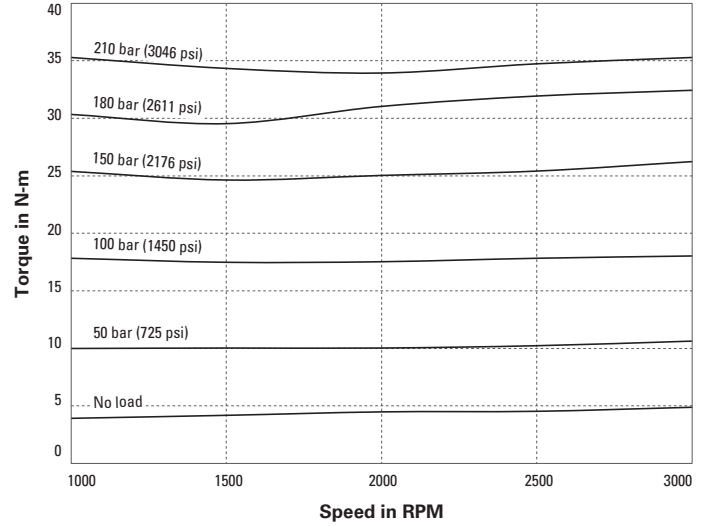
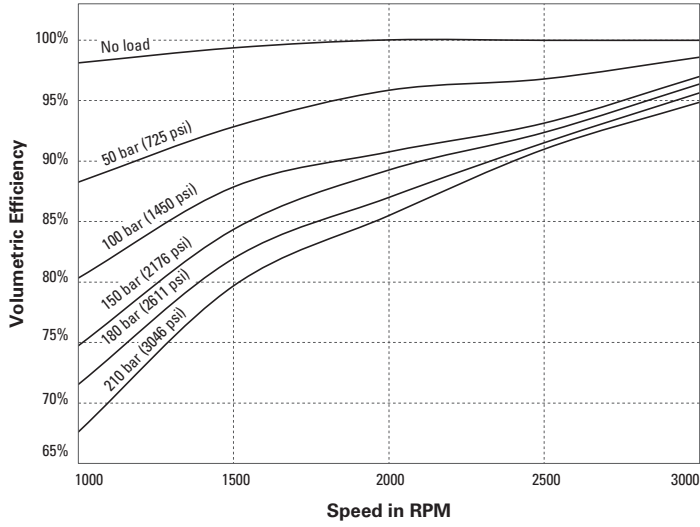

6.0cc

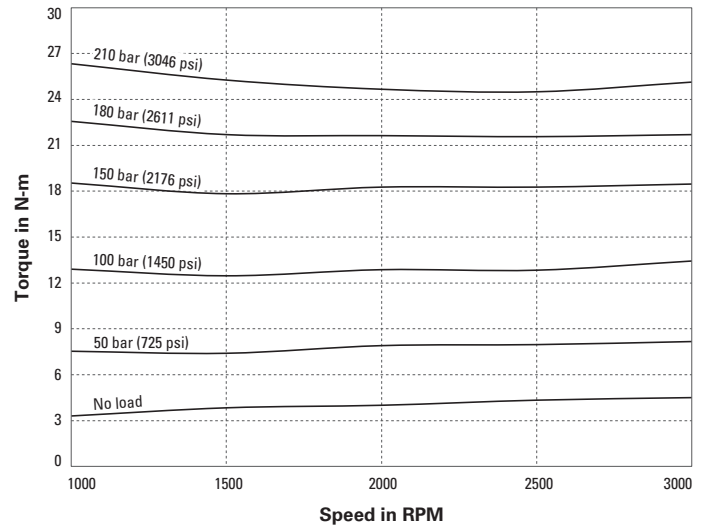
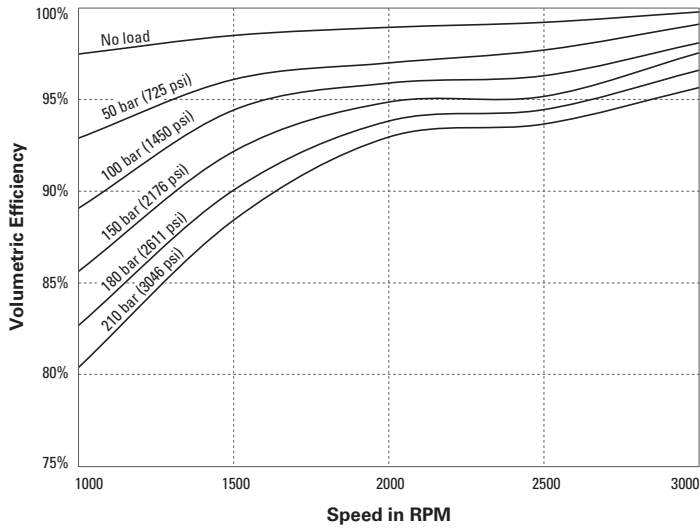

Performance data was collected using a mineral based oil with viscosity of 28 cSt at 45°C - 50°C

Performance Curves

Continued...

8.2cc

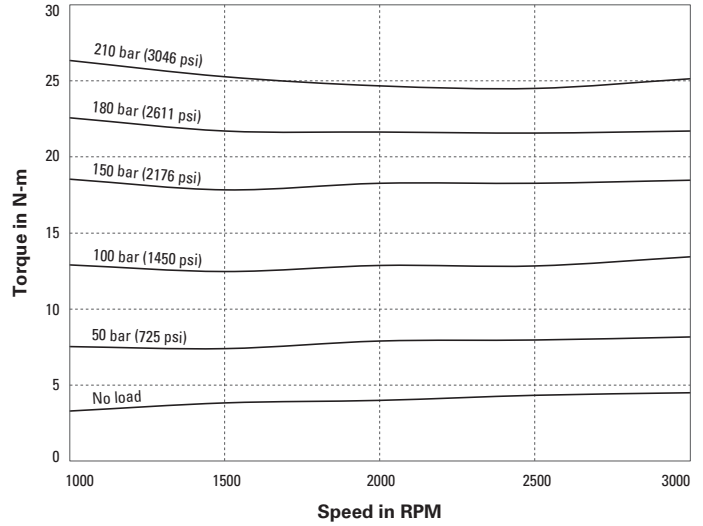
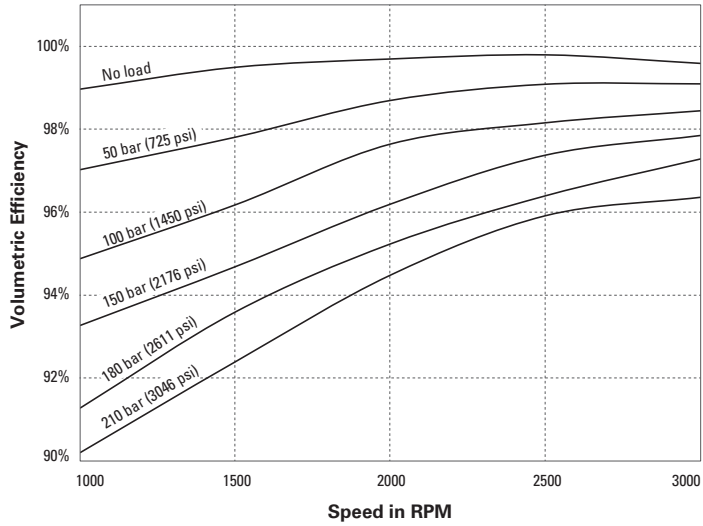

9.5cc

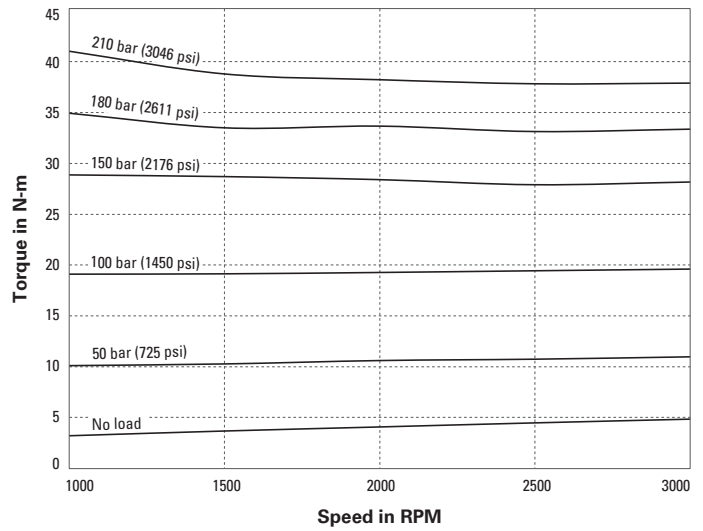
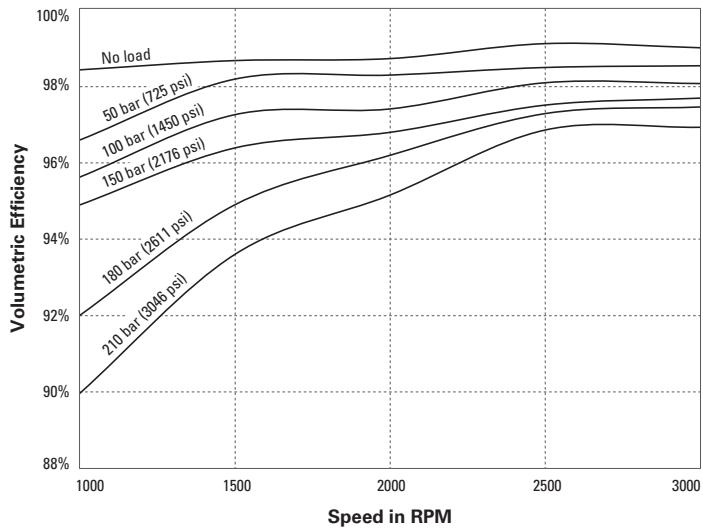

Performance data was collected using a mineral based oil with viscosity of 28 cSt at 45°C - 50°C

Performance Curves

Continued...

11.0cc

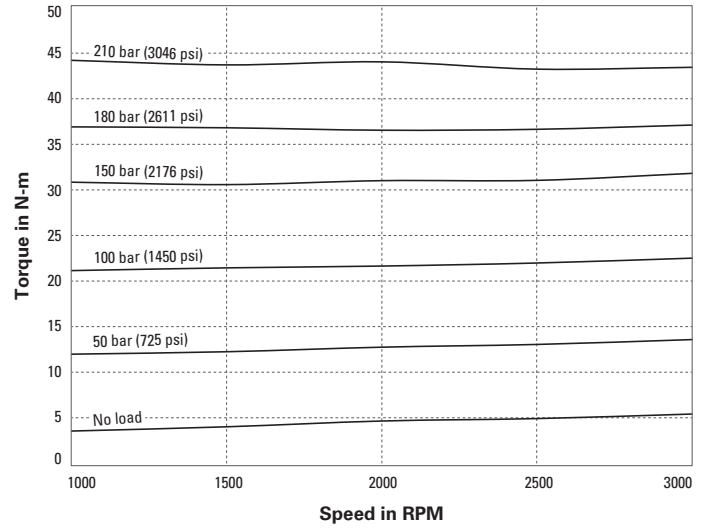
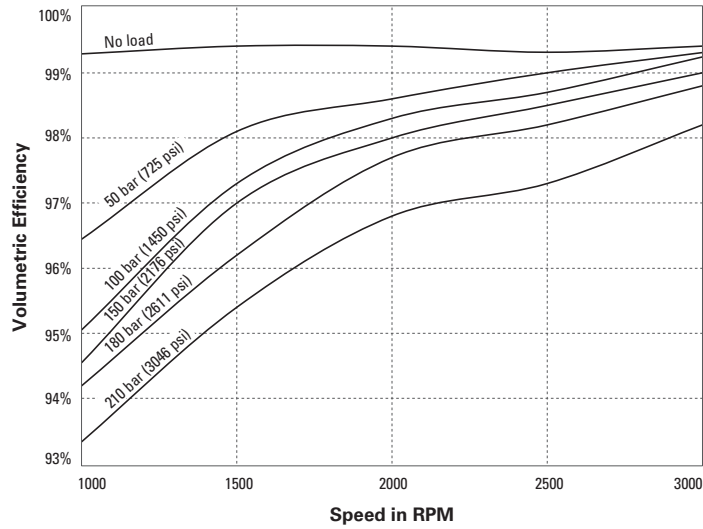

12.3cc

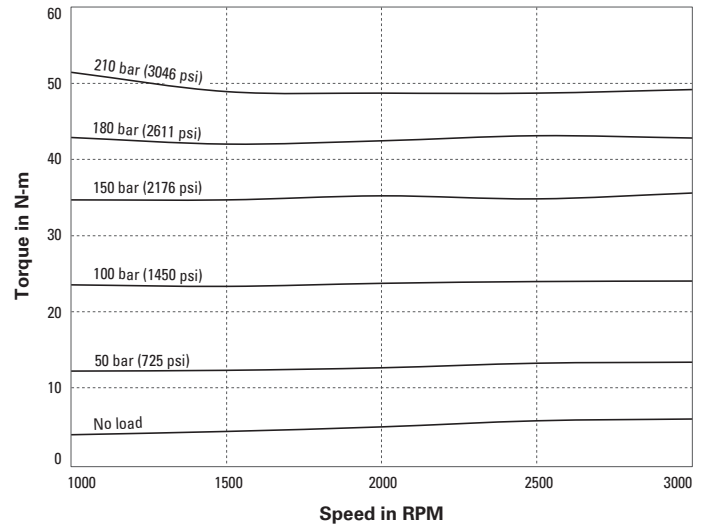
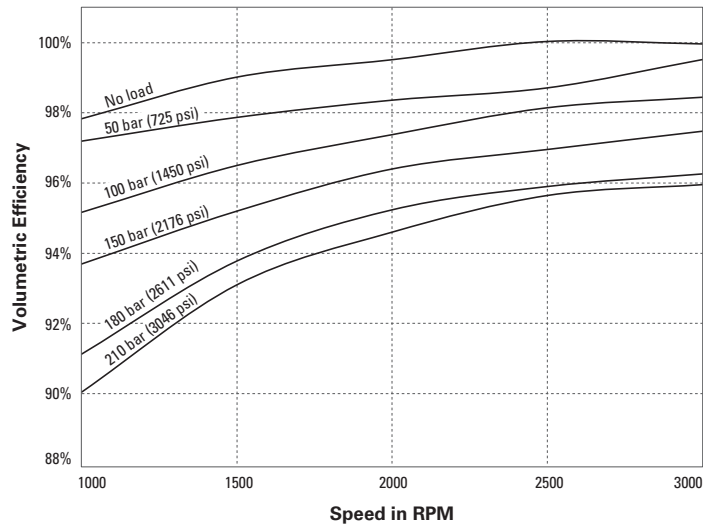

Performance data was collected using a mineral based oil with viscosity of 28 cSt at 45°C - 50°C

Performance Curves

Continued...

16.5cc

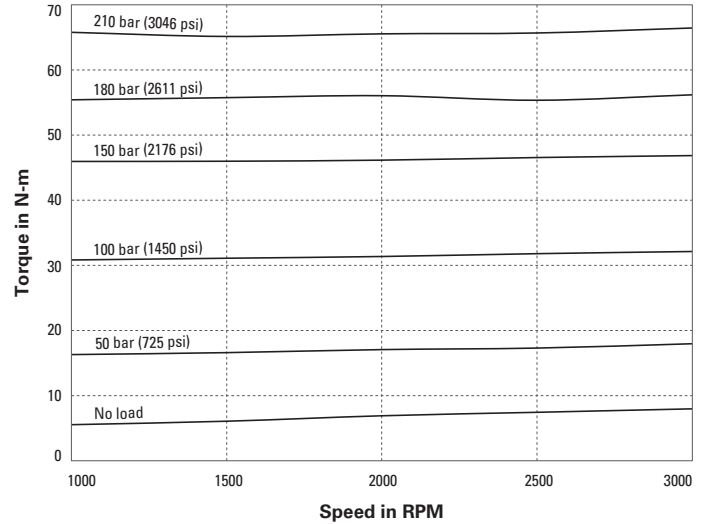
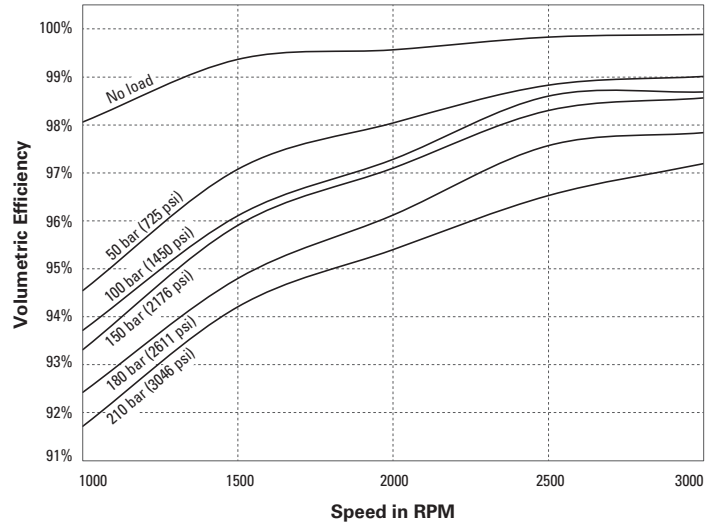

18.0cc

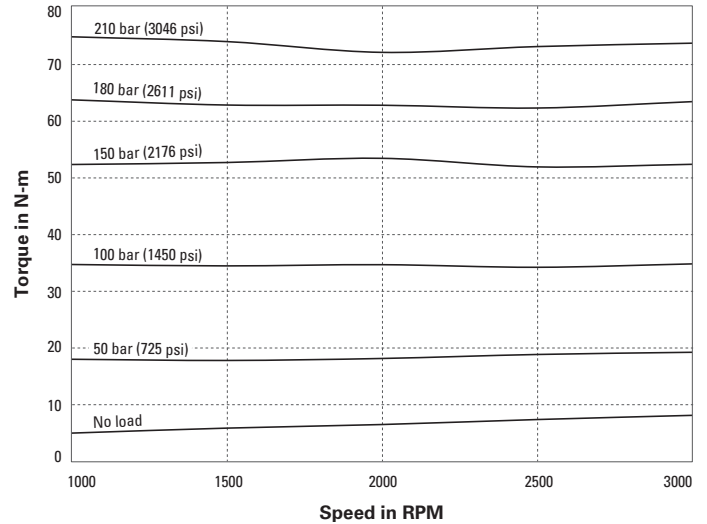
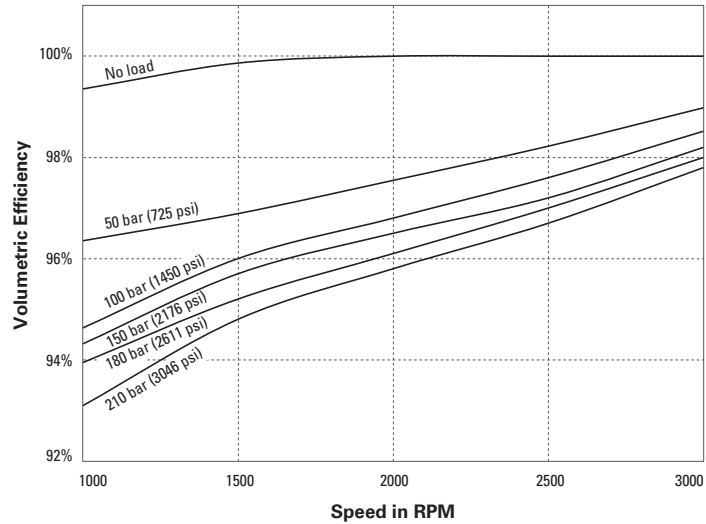

Performance data was collected using a mineral based oil with viscosity of 28 cSt at 45°C - 50°C

Performance Curves

Continued...

20.0cc

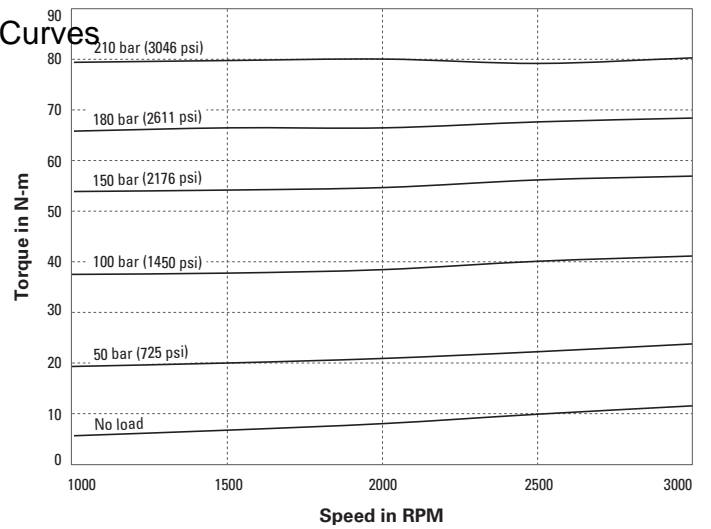
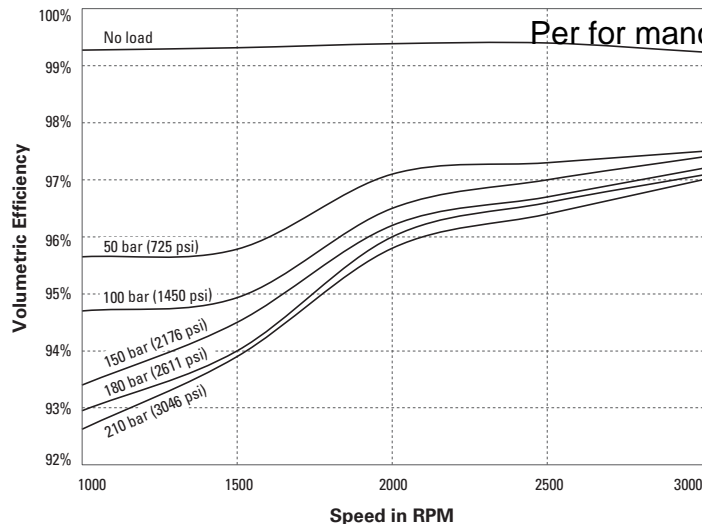

24.0cc

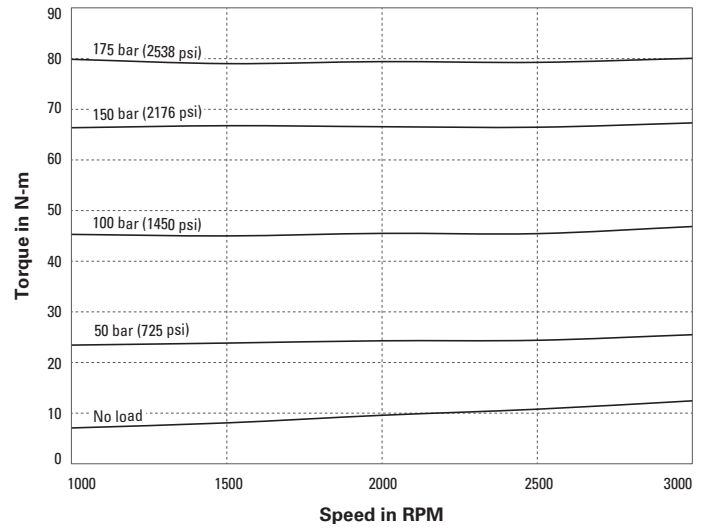
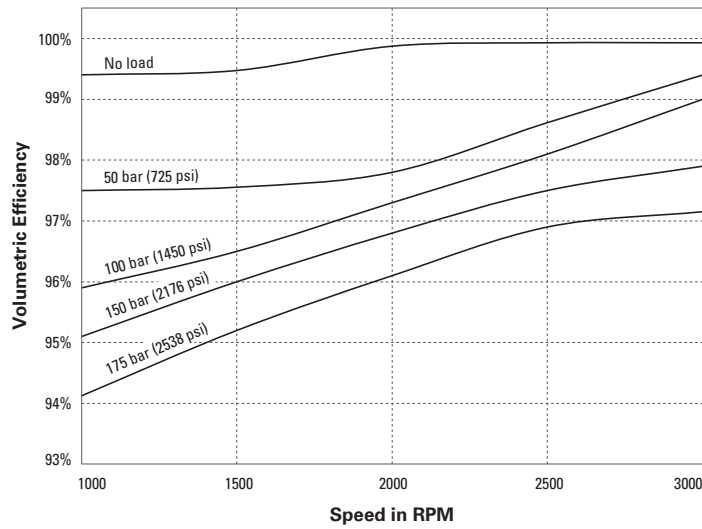

Performance data was collected using a mineral based oil with viscosity of 28 cSt at 45°C - 50°C

Component Dimensions

Mounting Flange Options

SAE "A" 2 Bolt

(Code – A1)

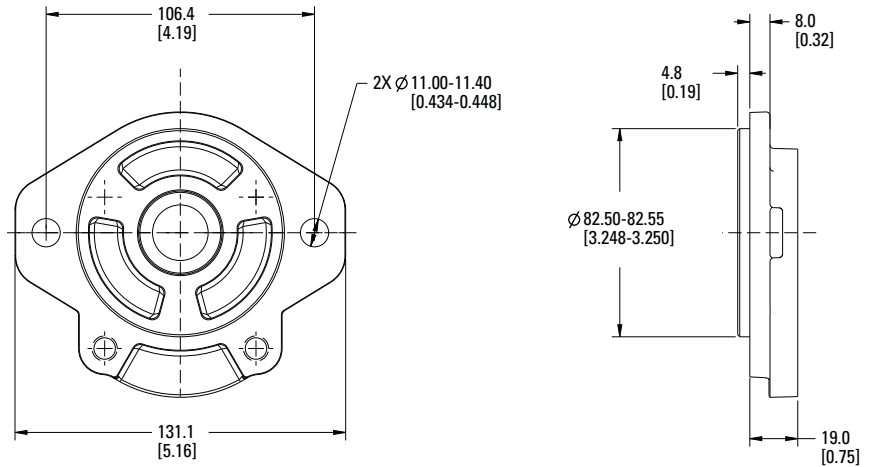

European Rectangular 4 Bolt

(Code – H1)

'A'		
$\begin{matrix} 0 \\ -0.05 \end{matrix}$	$\begin{matrix} 0 \\ -0.05 \end{matrix}$	$\begin{matrix} -0.03 \\ -0.08 \end{matrix}$
36.47	50.00	54.00
$\begin{bmatrix} 0 \\ -0.002 \\ 1.435 \end{bmatrix}$	$\begin{bmatrix} 0 \\ -0.002 \\ 1.968 \end{bmatrix}$	$\begin{bmatrix} -0.001 \\ -0.003 \\ 2.125 \end{bmatrix}$
'D'		
7.00	7.50	9.00
[0.275]	[0.295]	[0.354]

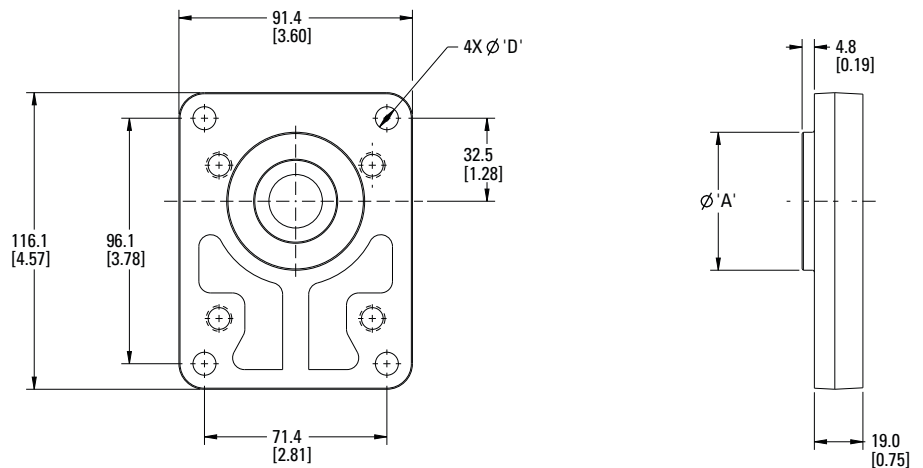

German Rectangular 4 Bolt

(Code – H2)

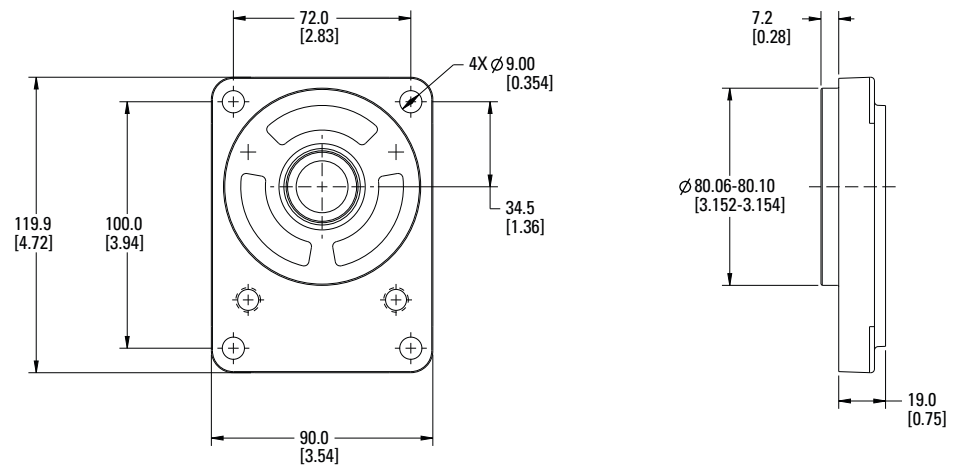

All dimensions are in mm [in]

Component Dimensions

Input Shaft Options

Taper 1:8 on dia.

(Code – 09)

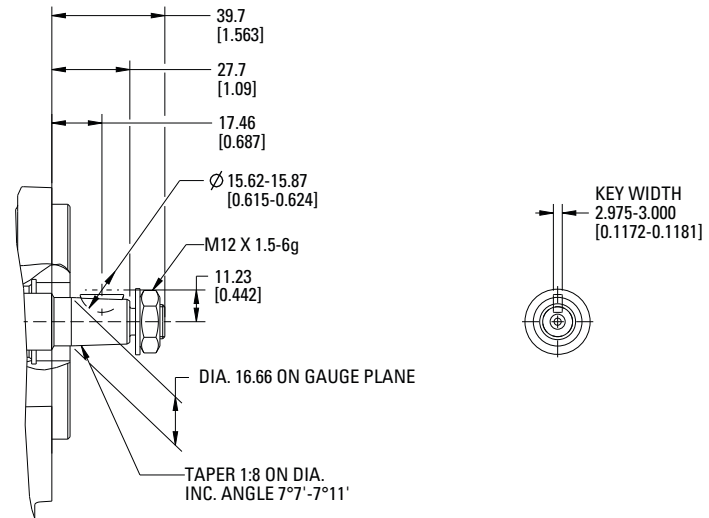

Straight Keyed Shaft with \varnothing 15.88

(Code – 24)

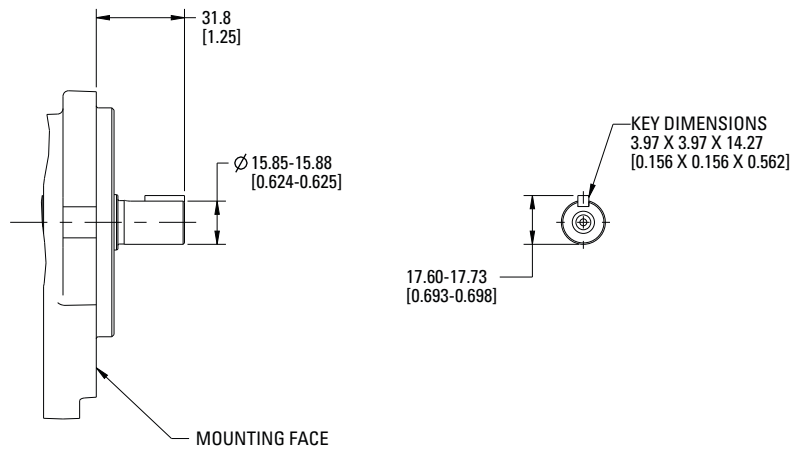

Straight Keyed Shaft with \varnothing 17.46

(Code – 21)

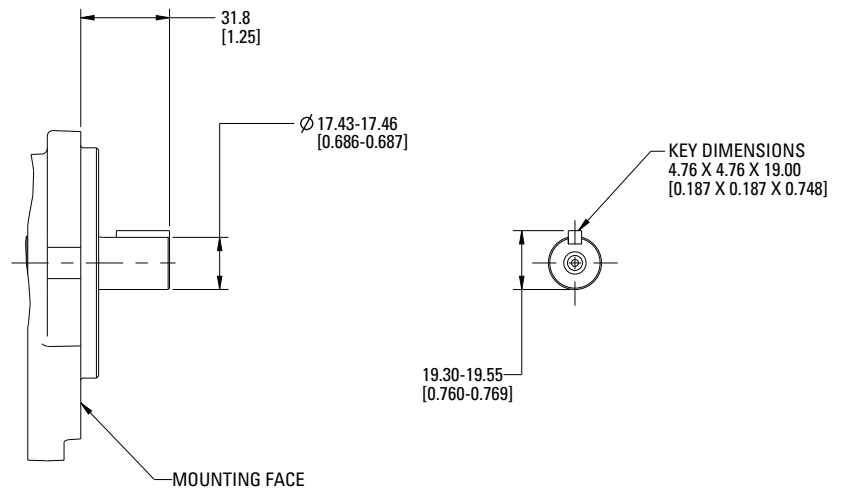

All dimensions are in mm [in]

Component Dimensions

Input Shaft Options Continued...

Straight Keyed Shaft with \varnothing 19.05

(Code – 22)

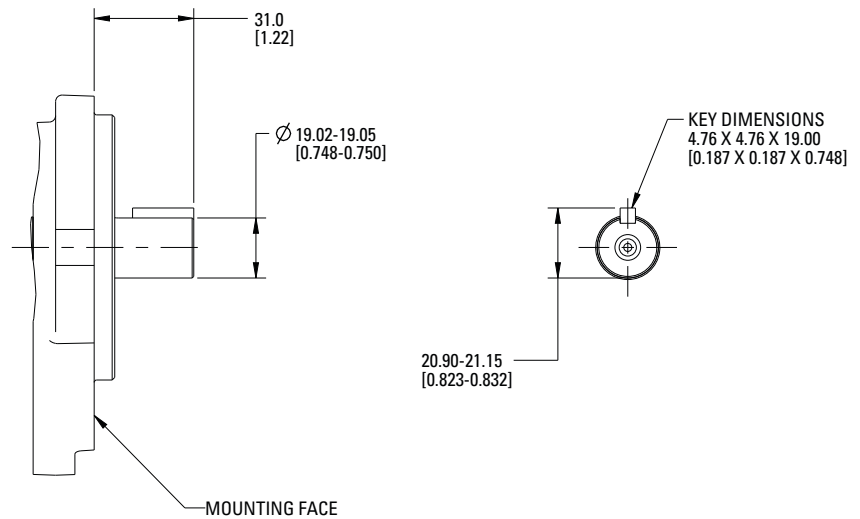

9 Teeth Shaft

(Code – 27)

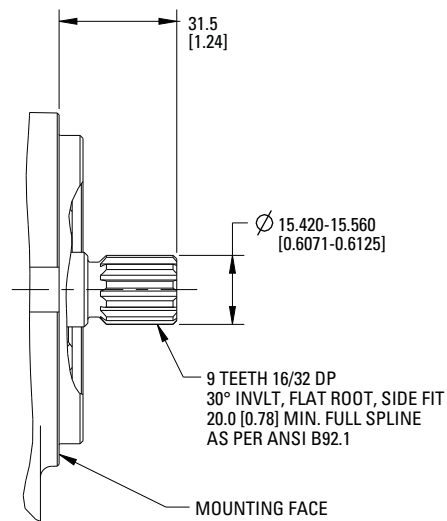

11 Teeth Shaft

(Code – 20)

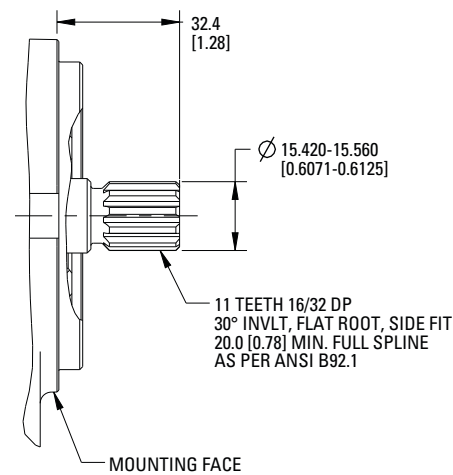

All dimensions are in mm [in]

Component Dimensions

Input Shaft Options Continued...

14 Teeth Shaft

(Code – 19)

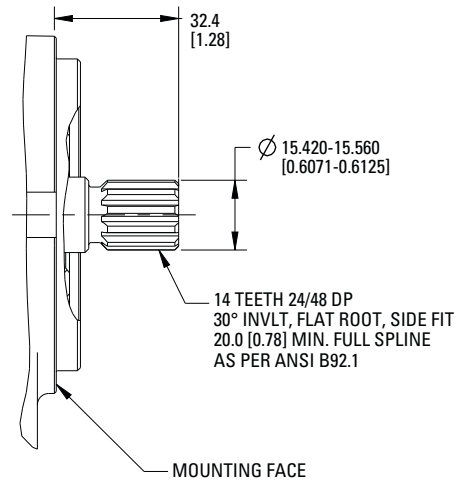

28 Teeth Shaft

(Code – 29)

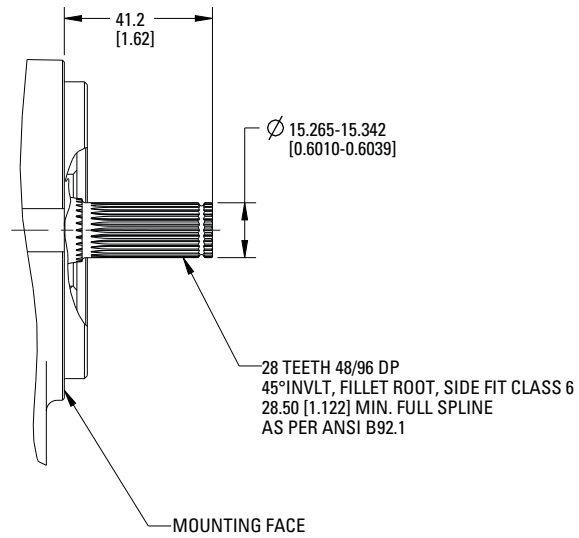

All dimensions are in mm [in]

Component Dimensions

Port Options

SAE Straight Thread O-Ring Ports

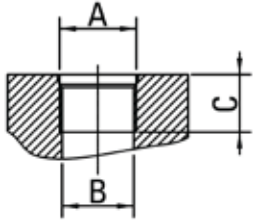

Code	SAE No.	A (Thread Size)	ØB mm (in)	C mm (in)
TJ	8	0.750-16 UNF-2B	17.5 (0.69)	14.3 (0.56)
TF	10	0.875-14 UNF-2B	20.5 (0.81)	16.7 (0.66)
TM	12	1.0625-12 UN-2B	24.9 (0.98)	19.1 (0.75)
TS	14	1.1875-12 UN-2B	28.1 (1.11)	19.1 (0.75)
TG	16	1.3125-12 UN-2B	31.3 (1.23)	19.1 (0.75)

European Flanged Ports – 4 Bolts

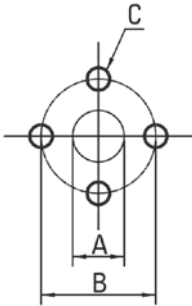

Code	Nominal Size	ØA mm (in)	B mm (in)	C Thread	C Thread Depth mm (in)
FB	14	14.0 (0.55)	30.0 (1.18)	M6	13 (0.51)
FA	19	19.0 (0.75)	40.0 (1.57)	M8	13 (0.51)

German Flanged Ports – 4 Bolts

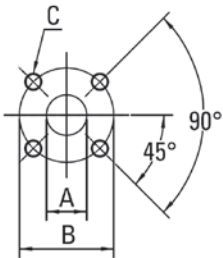

Code	Nominal Size	ØA mm (in)	B mm (in)	C Thread	C Thread Depth mm (in)
FO	15	15.0 (0.59)	35.0 (1.38)	M6	13 (0.51)
FP	19	19.0 (0.75)	40.0 (1.57)	M6	13 (0.51)
FN	20	20.0 (0.79)	40.0 (1.57)	M6	13 (0.51)

BSPP Straight Thread Ports

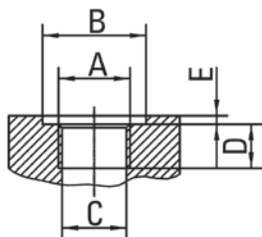

Code	Nominal Size	A	ØB mm (in)	ØC mm (in)	D mm (in)	E mm (in)
TR	3/8"	G 3/8"	27.0 (1.06)	15.3 (0.60)	12.2 (0.48)	1.5 (0.06)
TB	1/2"	G 1/2"	33.0 (1.30)	19.0 (0.75)	15.3 (0.60)	1.5 (0.06)
TC	3/4"	G 3/4"	42.0 (1.65)	24.5 (0.96)	16.0 (0.63)	1.5 (0.06)

Metric Straight Thread Ports (ISO 6149)

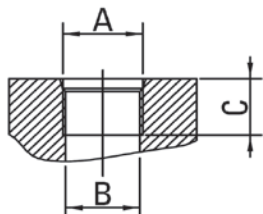

Code	A Thread Size	Ø B mm (in)	C mm (in)
TD	M18 × 1.5	16.5 (0.65)	12.5 (0.49)
TC	M22 × 1.5	20.5 (0.81)	13.5 (0.53)
TR	M27 × 2.0	25.0 (0.98)	17.0 (0.67)

Installation & Maintenance

Mounting

Pump can be mounted with Drive Shaft in horizontal, vertical or at any angle in between. All Flanges have pilot (Spigot) for proper alignment of Pump with respect to drive system.

Rotation

Shaft rotation is denoted in the unit coding. Arrow indicating direction of rotation is stamped on Pump's Centre Body. Direction of rotation is as viewed from Pump's Drive Shaft end.

Drives

Coupling used to drive the pump should not transfer any radial or axial load on Pump's Drive Shaft. A flexible coupling is recommended to accommodate slight misalignment & to dampen the vibration.

Fluids

Pressure ratings given in this catalog are based on petroleum based hydraulic fluids. Recommended viscosity range is as per specifications page of this catalog. Avoid using mixtures of two different oils which could result in decomposition & reduction of oil's lubricating capability. For use with other oils, consult Eaton representative for approval.

Fluid Reservoir

As a general rule of thumb, reservoir capacity for Industrial Systems with open loop flow should be at least 3 times as that of the flow. Pump suction line should draw oil from a point not less than 100 mm (4 Inch) above the tank bottom to avoid sludge deposits from entering the pump. Return line should be submerged in the oil & should be positioned as far apart as possible from the inlet line. Return & Inlet Lines should be separated by Baffles.

Lines

Inside diameter of inlet line must be as large as possible. Inlet line should be free from sharp bends, 90 degree Elbow Fittings or other restrictions which would cause resistance to flow. Positive head should be maintained at pump inlet as far as possible. However if pump is required to operate at low inlet pressure condition then inlet vacuum should not be less than 0.2 bar (6 inches of Hg). (If the inlet vacuum is outside of the recommendations, consult Eaton representative for approval). Maximum inlet pressure of the pump is limited by the Shaft Seal & should not exceed 2 bar gauge. Inside diameter of outlet line should be at least equal to the opening diameter of Outlet Port. Do not over tighten coupling connected to threaded type Inlet & Outlet Port as it may damage threads in pump body.

Filtration

Most of the premature failures of gear pumps are due to contaminated Fluid. Oil contamination level should not exceed ISO cleanliness code 20/18/13 per ISO 4406:99. Full flow filtering is always recommended. Initial cleanliness level of the fluid with which system is filled must not exceed NAS 1638 Class 9.

Starting up

Fill the pump with fluid before installing. Check direction of rotation. It should be in line with arrow marked on the pump. Check that all fitting connections are torqued to proper specifications. For first run of the pump gradually increase pressure & speed until operating levels are obtained.

Periodic checks

Keep outside surface of the pump clean, especially area near to the Drive Shaft Seal. Contact of abrasive powder with Shaft Seal will cause faster wear of the seal & will lead to leakage. Replace Filters regularly in order to keep Hydraulic Fluid clean. Monitor oil level & replenish oil if necessary.

Changing Rotation

To change rotation of pump

1. Clean the pump externally with care.
2. Coat the sharp edges of the Drive Shaft **3** with adhesive tape & smear a layer of clean grease on the Shaft end extension to avoid damaging the lip of the shaft seal when removing the Mounting Flange.
3. Loosen & remove the Clamp Bolts **5**
4. Remove the Mounting Flange **1** taking care to keep the Flange as straight as possible during removal. If the Flange is stuck, tap around the edge with a fibre or rubber mallet in order to break away from the body. Ensure that while removing the front Mounting Flange, the Drive Shaft & other components remain in position.
5. Remove front Bushing block **2** do not remove rear Back Plate or Bushing block.
6. Remove the Driven Gear **4** without overturning. The Rear Plate is not to be removed.
7. Re-locate the Driven Gear **4** in the position previously occupied by the Drive Gear **3**.
8. Re-locate the Drive Gear **3** in the position previously occupied by the Driven Gear **4**.
9. Replace the Bushing block **2** in its original position.
10. Gently wipe the machined surface of the Mounting Flange **1**.
11. Refit the front Mounting Flange **1** turned 180 degree from its original position.
12. Refit the clamp bolts **5** & tighten in a crisscross pattern with the following torque value –
 - For Single Pump with Aluminium End Cover – 45 N-m (398 lbf-in).
 - For Double Pump with Aluminium end cover – 55 N-m (487 lbf-in).
 - For both Single & Double Pump with Cast Iron end cover – 65 N-m (575 lbf-in).
13. The pump is ready for installation with the original rotation reversed.

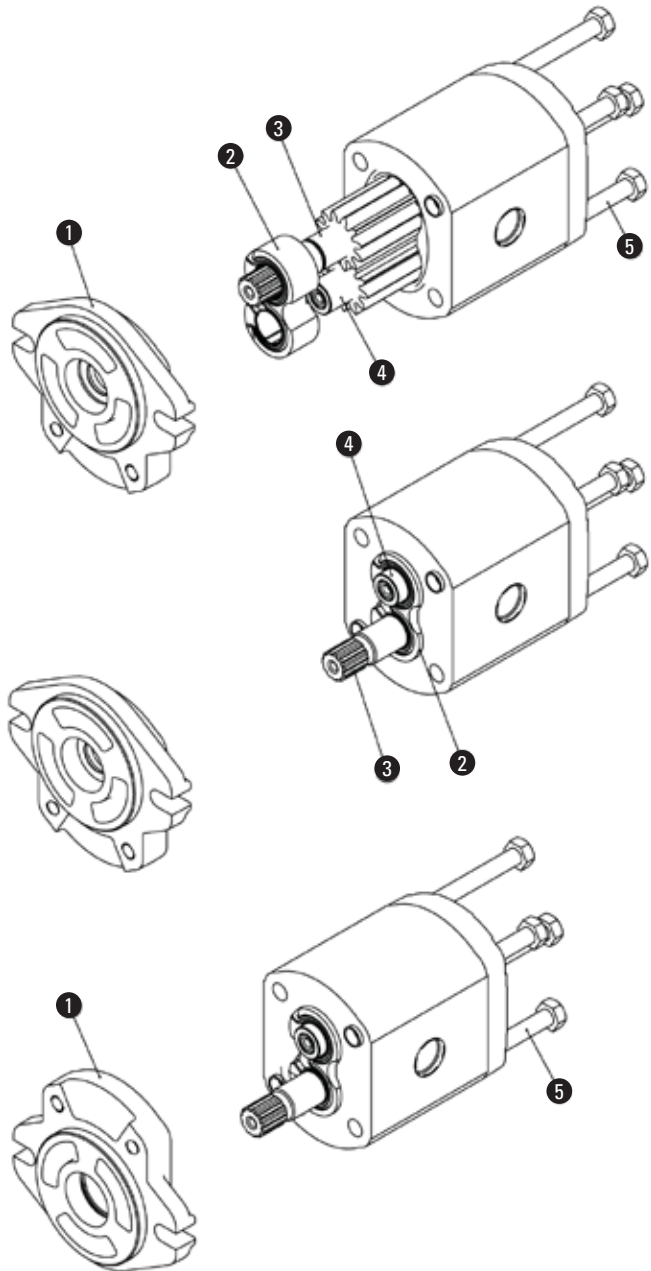

⚠ Changing Rotation should be done by a trained service person or an authorized distributor.

Spares

Seal Kit

Single pump with no Special Feature

Part No.

931547	Nitrile
9901061-000	Viton

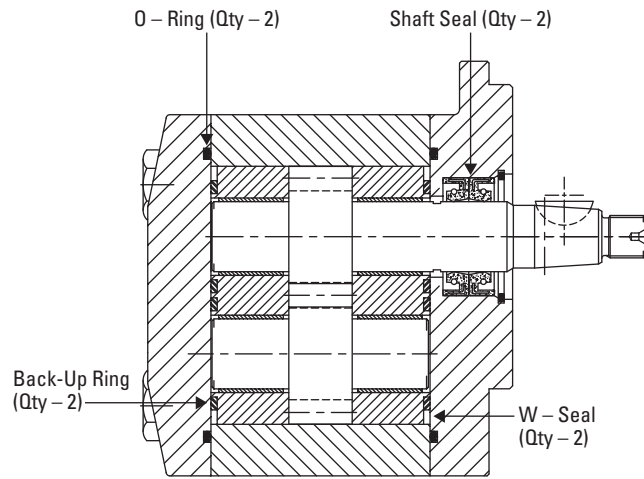

Double Pump with Sectional Sealing

(For two separate grades of oil)

Part No.

5001676-001	Nitrile
9901063-000	Viton

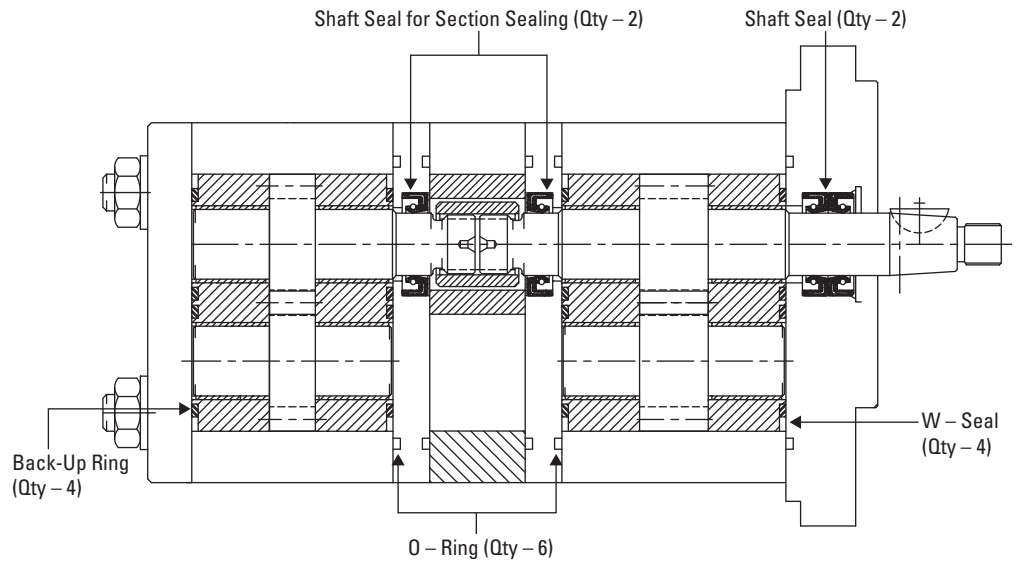

Double Pump

(For common oil)

Part No.

5001589-001	Nitrile
9901062-000	Viton

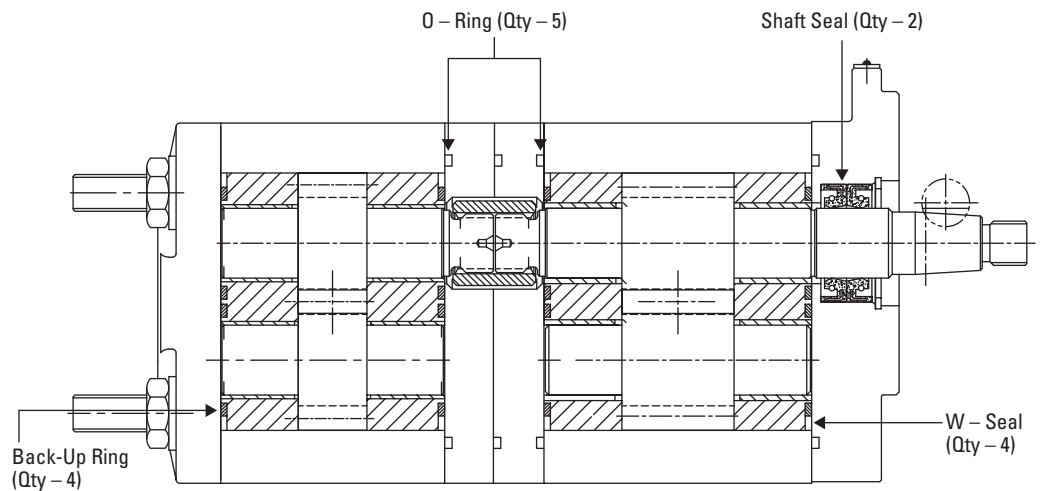

Shandong Topkit Construction Machinery Equipment Co., Ltd., is a high-tech company specialized in the manufacturing and supplying for hydraulic pumps, valves, motors, reducers , gearboxes, etc.

We mainly focuses on hydraulic parts for hydraulic excavators, and the products have been serialized. We dedicated on the following three systems and five series products. We specialized in Positive flow system, negative flow system, load sensing control system;

Five series refer to 6-ton products, 8-ton products, 20-ton products, 40-ton products, concrete series products.

Our featured products 20-ton excavator negative flow pump, positive flow pump, positive flow valve, and rotary motor passed the national appraisal in 2012.

In quality control, we passed the ISO2001:2015 quality management system certification in 2022; and we also passed the ISO14001:2015 environmental management system certification in this year. We always persist in the quality control and try best to enhance quality all the time.

In R&D Field, we have a professional team with more than 10 people, of which more than 90 % have accumulated more than ten years of hydraulic product technology, and have become the main force for the company to develop new products.

Now our products has exported to dozens of countries, such as Russia, Middle East countries , Asian and African countries. We will continue to develop new products in top quality, and sincerely wish establishing business cooperation with more friends. Thanks

phone : +86 150 539 47199

whatsapp : +86 150 539 47199

email:george@topkitparts.com

web:eatonhydrolics.com

topkitparts.com