

Eaton High-Pressure Closed-Circuit Piston Pumps Service Manual



EATON

Powering Business Worldwide

Series 2 Variable Displacement Piston Pump

ACL



Table of Contents

Features	3
Specifications and Performance Data	4
Charge Pump Performance Data	5
Model Code	6 - 7
Pump Features and Options	8
Control Options: Position 18-19	
Manual Control	9 - 10
Hydraulic Remote Control	11
Electronic Proportional Displacement Control	12
Solenoid Control with Swashplate Feedback Sensor	13
Forward - Neutral - Reverse Control	14
Controls Special Features Destroke Valve	14
Pump Dimensions	
Model 64, 75 - Opposite Side Porting	15 - 16
Model 64, 75 - Same Side Porting	17
Model 89, 105 - Opposite Side Porting	18 - 19
Model 89, 105 - Same Side Porting	20
Input Shaft Options	21
Auxiliary Mount Options	22 - 23
Operational Diagram	24
Application Information	25 - 27
Hydraulic Fluid Recommendations	28 - 29

The Eaton Series 2 Variable Displacement Piston Pump

The Advanced Series 2 heavy duty pump, with a cradle swashplate design, combines the time-tested reliability you expect from Eaton with compact packaging, exceptional control and quiet operation.

The Series 2 single piece pump housing provides exceptional strength and soundproofing. Eaton's cast iron housing has only one major opening versus two openings for competitive pumps. This provides a stronger, more rigid pump housing and reduces the number of gasketed joints.

The high-strength, one-piece swashplate has the swashlever and servo-pin integrated into the swashplate, delivering increased reliability without adding extra weight.

A large diameter single servo piston permits pump operation at lower charge pressures, minimizing parasitic charge pump losses for increased overall pump efficiency. A large centering spring, housed within the servo piston, returns the pump to neutral in the event of control pressure loss.

The new integral gerotor type charge pump combines excellent suction/speed capabilities in a compact design. Several displacement options are available to suit the needs of every application, including tandem pumps.

Features

- 430 bar pressure rating
- Speeds to 4510 rpm
- Accurate controllers
- Quiet operation
- Optional input shafts

A variety of available drive shaft configurations

– straight keyed, splined, or tapered – ensures the proper shaft for your application.

The serviceable bi-metal bearing plate has steel for high pressure capability and a bronze bearing face for high speed capabilities.

Typical Applications:

- Road roller/compactor
- Harvesting equipment
- Lift truck
- Wheel loader
- Agricultural sprayer
- Auxiliary and industrial drives

SAE auxiliary mounts:

"A," "B," "B-B" and "C" are available with and without charge pump. Excellent torque capability allows high horsepower to work circuits without multiple pump drives.

The main system ports – SAE code 61 and code 62 – are available with SAE or Metric threads. Opposite side and same side configurations are now available to accommodate a wide range of installations.

Specifications and Performance

Model		64	75	89	105
Displacement cm^3/r (in^3/r)		64 (3.9)	75 (4.6)	89 (5.4)	105 (6.4)
Input Mounting Flange		SAE C	SAE C	SAE C	SAE C
Max. Shaft Speed* RPM @ Max. Displ.		4165	4165	3720	3720
Nominal Pressure* bar (psi)		430 (6250)	430 (6250)	430 (6250)	430 (6250)
Peak Pressure** bar (psi)		500 (7250)	500 (7250)	500 (7250)	500 (7250)
Case Pressure bar (psi)	Cont. Max.	2,25 (40) 13,8 (200)	2,25 (40) 13,8 (200)	2,25 (40) 13,8 (200)	2,25 (40) 13,8 (200)
Output Flow l/min @ 240bar gal/min @ 3500 psi		255 (67.2)	301 (79.5)	318 (84.1)	376 (99.4)
Input Torque					
N·m @ 240 bar lbf·in @ 3500 psi		256 (2278)	303 (2694)	358 (3189)	424 (3771)
Temperature Rating		82°C (180°F)	82°C (180°F)	82°C (180°F)	82°C (180°F)
Weight (opposite side porting)		58 kg (128 lbs)	58 kg (128 lbs)	81 kg (178 lbs)	81 kg (178 lbs)

* Nominal Pressure: Max delta system pressure at which component fatigue does not occur (pump life estimated by bearing life).

** Peak Pressure: Max operation pressure which is permissible for a short duration of time ($t < 1$ sec).

Performance Data

Input Torque vs Speed

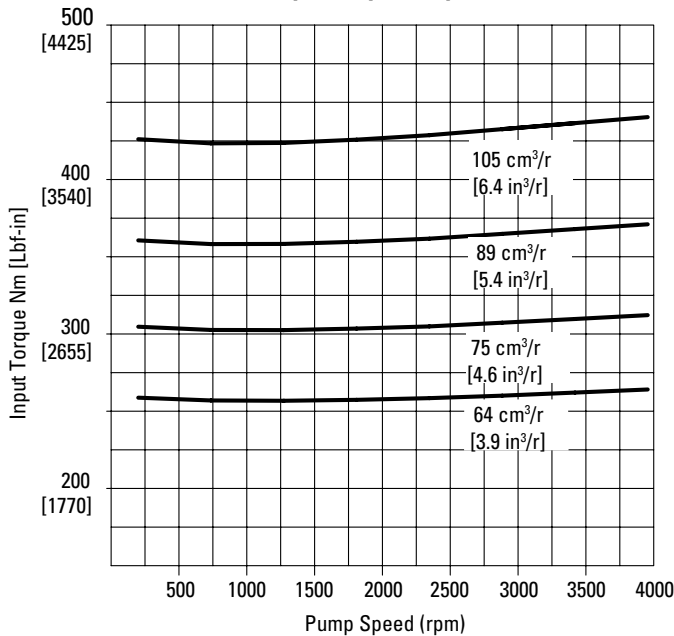

Output Flow vs Speed

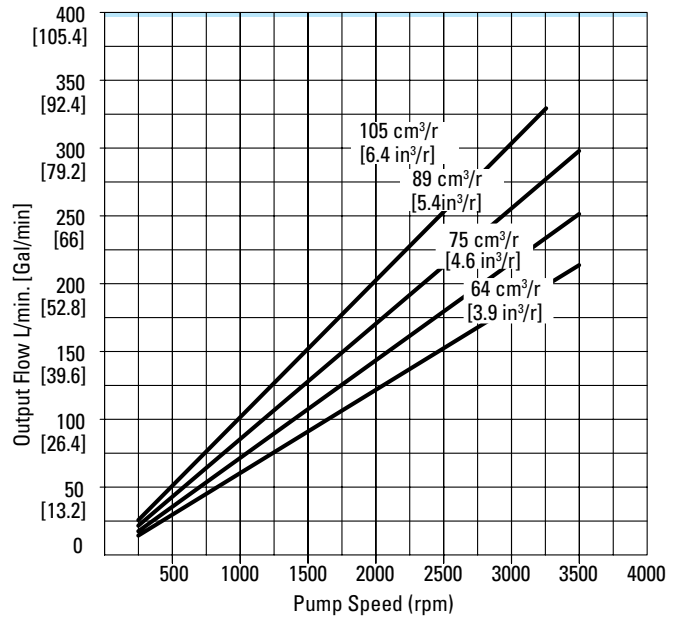

System pressure 240 bar (3500 psi)
 Oil viscosity 10 cst (60 sus)
 Temperature 82°C (180°F)

Performance – Charge Pump

Eatons Series 2 pump offers a choice of five integral charge pump displacements. The Charge Pump design allows greater through-torque for tandem pumps and multiple motor applications. These charge pumps include

a large standard suction port and a gauge/pilot pressure port. Charge pump pressure side filtration is also available (see page 29).

The charge pump generates a low pressure flow of oil to perform the following functions:

1. Keeps the closed loop circuit full of oil.
2. Provides control pressure to the pump's displacement control servo valve for easy control of the transmission's output speed.
3. Provides cool, clean oil from the reservoir to keep the transmission pump and motor well lubricated and cooled.
4. Supplies a positive boost pressure to the pistons of the piston pump and piston motor.

Charge Pump Performance

Charge Pump Displacement*	cm³/r in³/r	13,9 0.85	17,4 1.06	21,0 1.28	27,9 1.70	34,7 2.12
Maximum Shaft Speed	rpm	4300	3700	3300	2700	2250
Output Flow** at Max Speed Input	l/min gal/min	59,9 15.8	64,3 17.0	69,2 18.3	75,2 19.9	78,2 20.6
Horsepower** at Max Speed	kW HP	2,10 2.81	2,25 3.02	2,42 3.25	2,63 3.53	2,74 3.67
Series 2 Pump Displacement	64 cm ³ /r (3.9 in ³ /r) 75 cm ³ /r (4.6 in ³ /r) 89 cm ³ /r (5.4 in ³ /r) 105 cm ³ /r (6.4 in ³ /r)	Standard	Optional	Optional	Optional	N/A
		Optional	Standard	Optional	Optional	Optional

Charge Pump Power vs Speed

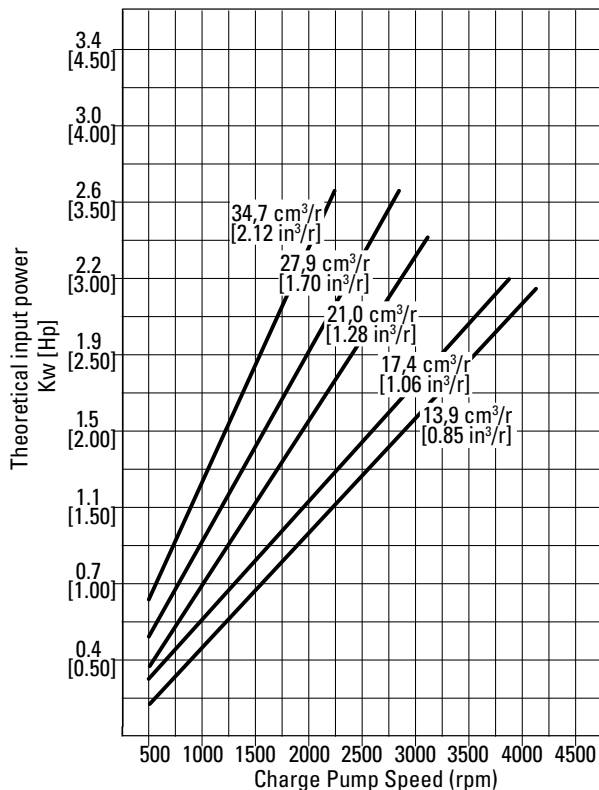

Charge Pump Flow vs Speed

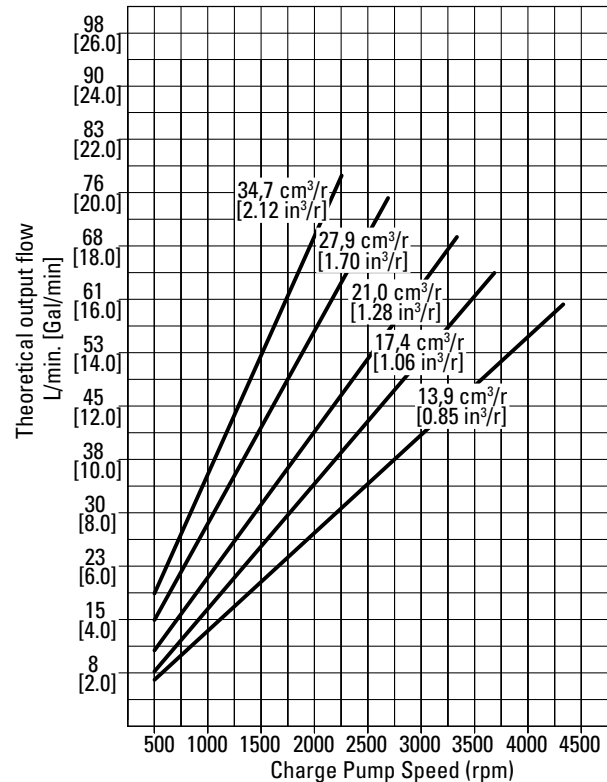

Oil Viscosity 10 cst (60 sus)
Temperature 82° C (180°F)

Model Codes

The following 31-digit coding system has been developed to identify all of the configuration options for the Series 2 hydrostatic pump. Use this model code to specify a pump with the desired features. All 31-digits of the code must be present when ordering. You may want to photocopy the matrix below to ensure that each number is entered in the correct box.

ACL	054	02	L	0	B	TT	WW	12	EC	B	C	D	0	3	C	A	B	0	0	0	A
1, 2, 3	4, 5, 6	7, 8	9	10	11	12, 13	14, 15	16, 17	18, 19	20	21	22	23	24	25	26	27	28	29	30	31

1, 2, 3 Pump Series
ACL – Hydrostatic-Heavy Duty Variable Pump (Series 2)

4, 5, 6 Displacement
064 – 64 cm³/r (3.8 in³/r)
075 – 75.3 cm³/r (4.6 in³/r)
089 – 89 cm³/r (5.4 in³/r)
105 – 105 cm³/r (6.4 in³/r)

7, 8 Input Shaft
03 – SAE C-C (1.50) diameter tapered with (.375) x (1.00) square key
14 – SAE C 14 tooth 12/24 pitch spline
21 – SAE C-C 21 tooth 16/32 pitch spline
23 – SAE C-C 23 tooth 16/32 pitch spline

9 Input Rotation
L – Counterclockwise (lefthand)
R – Clockwise (righthand)

10 Valve Plate
0 – V-groove
1 – Propel
3 – Quiet valve plate

11 Main Ports (Includes Gage Ports)
A – 25.4 (1.00) - code 61 per SAE J518
B – 25.4 (1.00) - code 62 per SAE J518
E – 25.4 (1.00) - code 62 per SAE J518 same side location
F – 25.4 (1.00) - code 61 per SAE J518 same side location

12, 13 High Press Relief Valve Setting
Port A (Pos. 12)
Port B (Pos. 13)
0 – None
M – 207 bar (3000 psi) with 2 bar (29 psi) check valve spring
N – 241 bar (3500 psi) with 2 bar (29 psi) check valve spring
P – 276 bar (4000 psi) with 2 bar (29 psi) check valve spring
R – 310 bar (4500 psi) with 2 bar (29 psi) check valve spring
S – 345 bar (5000 psi) with 2 bar (29 psi) check valve spring
T – 379 bar (5500 psi) with 2 bar (29 psi) check valve spring
U – 414 bar (6000 psi) with 2 bar (29 psi) check valve spring
V – 431 bar (6250 psi) with 2 bar (29 psi) check valve spring
W – 448 bar (6500 psi) with 2 bar (29 psi) check valve spring
Y – 483 bar (7000 psi) with 2 bar (29 psi) check valve spring

14, 15 Press Override Setting
Port A (Pos. 14)
Port B (Pos. 15)
0 – none
1 – 448 bar (6500 psi) adjustable range 379-448 bar (5500-6500 psi)
N – 103 bar (1500 psi) adjustable range 103-275 bar (1500-4000 psi)
P – 138 bar (2000 psi) adjustable range 103-275 bar (1500-4000 psi)
R – 172 bar (2500 psi) adjustable range 103-275 bar (1500-4000 psi)
S – 207 bar (3000 psi) adjustable range 103-275 bar (1500-4000 psi)
T – 241 bar (3500 psi) adjustable range 103-275 bar (1500-4000 psi)
U – 276 bar (4000 psi) adjustable range 241-345 bar (3500-5000 psi)
V – 310 bar (4500 psi) adjustable range 241-345 bar (3500-5000 psi)
W – 345 bar (5000 psi) adjustable range 310-414 bar (4500-6000 psi)
Y – 379 bar (5500 psi) adjustable range 310-414 bar (4500-6000 psi)
Z – 414 bar (6000 psi) adjustable range 379-448 bar (5500-6500 psi)

16, 17 Special Pump Features
00 – No special features
01 – Plugged magnetic speed sensor port
02 – Magnetic speed sensor
12 – Rear pump unit for tandem assembly (no shaft seal)
13 – Servo piston with externally adjustable stops in both directions

18, 19 Control
EC – Electronic proportional control 12 volt dc without electronic driver
ED – Electronic proportional control 24 volt dc without electronic driver
FR – Forward-neutral-reverse control 12v with 2 2-pin weatherpack connectors
FS – Forward-neutral-reverse control 24v with 2 2-pin weatherpack connectors
HA – Hydraulic remote control 5-15 bar (73-218 psi)
HB – Hydraulic remote control 2-14 bar (29-203 psi)
MA – Manual displacement control
MB – Manual displacement control with normally closed neutral lockout switch (wide band neutral)
MC – Manual displacement control with neutral detent (wide band neutral)
MG – Manual displacement control with normally open neutral lockout switch (wide band neutral)
ML – Manual displacement control with wide band neutral
SA – Solenoid control 12 Volt with non-contact feedback sensor with 4 pin Metri-pack connector
SB – Solenoid control 24 Volt with non-contact feedback sensor with 4 pin Metri-pack connector
SE – Solenoid control 12 volt with non-contact feedback sensor with electrical connectors per DIN 43650
SG – Solenoid control 24 volt with non-contact feedback sensor with electrical connectors per DIN 43650

Model Codes

The following 31-digit coding system has been developed to identify all of the configuration options for the Series 2 hydrostatic pump. Use this model code to specify a pump with the desired features. All 31-digits of the code must be present when ordering. You may want to photocopy the matrix below to ensure that each number is entered in the correct box.

A	C	L	0	5	4	0	2	L	0	B	T	T	W	W	1	2	E	C	B	C	D	0	3	C	A	B	0	0	0	A	
1, 2, 3	4, 5, 6	7, 8	9	10	11	12, 13	14, 15	16, 17	18, 19	20	21	22	23	24	25	26	27	28	29	30	31										

20,21,22 Control Orifice

Supply P (Pos. 20)

Lower Servo S1 (Pos. 21)

Upper Servo S2 (Pos. 22)

0 – None

A – 0.53 (.021) diameter

B – 0.71 (.028) diameter

C – 0.91 (.036) diameter

D – 1.12 (.044) diameter

E – 1.22 (.048) diameter

F – 1.32 (.052) diameter

G – 1.45 (.057) diameter

H – 1.65 (.065) diameter

J – 1.85 (.073) diameter

K – 2.06 (.081) diameter

L – 2.39 (.094) diameter

M – 2.59 (.102) diameter

23 Control Special Features

0 – No control special features

1 – No manual control lever

24 Charge Pump Displacement

0 – None

1 – 13.9 cm³/r (.85 in³/r)
(models 064-089)

2 – 17.4 cm³/r (1.06 in³/r)
(models 064-105)

3 – 21.0 cm³/r (1.28 in³/r)
(models 064-105)

4 – 27.9 cm³/r (1.70 in³/r)
(models 064-105)

5 – 34.7 cm³/r (2.12 in³/r)
(models 089-105)

25 Auxiliary Mounting

1 – None (models 064-105)

C – A-pad, dual 2 bolt mount,
no shaft seal, 9 tooth
16/32 pitch spline

D – B-pad, dual 2 bolt mount,
no shaft seal, 13 tooth
16/32 pitch spline

E – B-B-pad, dual 2 bolt
mount, no shaft seal, 15
tooth 16/32 pitch spline

F – C-pad, 4 bolt mount, no
shaft seal, 14 tooth 12/24
pitch spline

H – C-pad, integral to end
cover (typically front pump
of tandem), 4 bolt mount,
no shaft seal, 27 tooth
24/48 pitch spline for units
without charge pump

K – A-pad, dual 2 bolt mount,
no shaft seal, 11 tooth
16/32 pitch spline

26 Charge Pump Options

0 – None

A – Remote filter ports

B – Intergral pressure side
filter with 4 position
mounting pad

F – Remote filter ports. labeled

27 Charge Pressure Relief Valve Setting

0 – None

A – 21 bar (305 psi) - standard

B – 23 bar (326 psi)

C – 24 bar (348 psi)

D – 26 bar (370 psi)

E – 27 bar (392 psi)

F – 29 bar (413 psi)

G – 30 bar (435 psi)

H – 23 bar (340 psi)

K – 22 bar (320 psi)

28 Charge Pump Special Features

0 – No charge pump special features

29 Paint and Packaging

0 – Painted primer blue
(standard)

30 Identification On Unit

0 – Standard

31 Design Code

A – A

Features and Options

Series 2 Pump

High Pressure Relief Valve Model Code Position 12 & 13

The High Pressure Relief Valves for ports A and B are direct acting and help protect system components from excessive pressure spikes. The valves activate whenever system pressure equals the relief valve setting. The valves

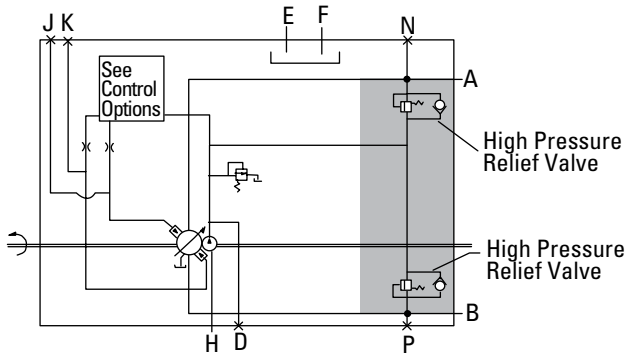

Pressure Override Model Code Position 14 & 15

The Pressure Override Control (POR) is used in combination with the high pressure relief valves, to protect the transmission when operated for extended periods at overload

pressures. If the system pressure reaches a preset limit, the pump destrokes and adjusts its displacement to the load. The POR is available in a number of pressure settings.

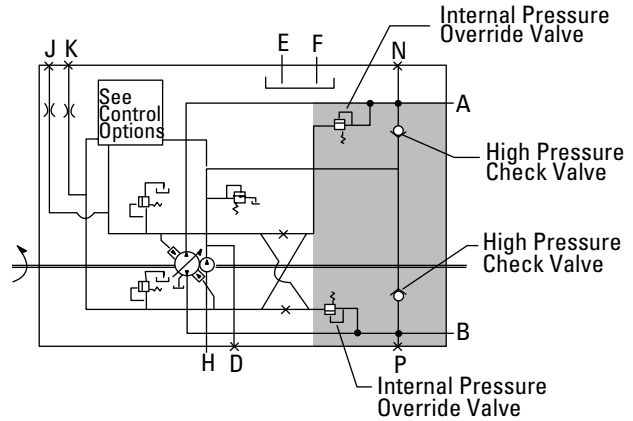

Special Pump Features Model Code 02 in Position 16 & 17

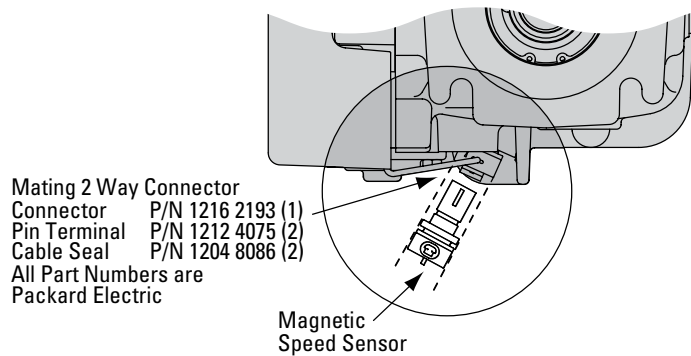

Special Pump Features Model Code 03, 13, or 14 in Position 16 & 17

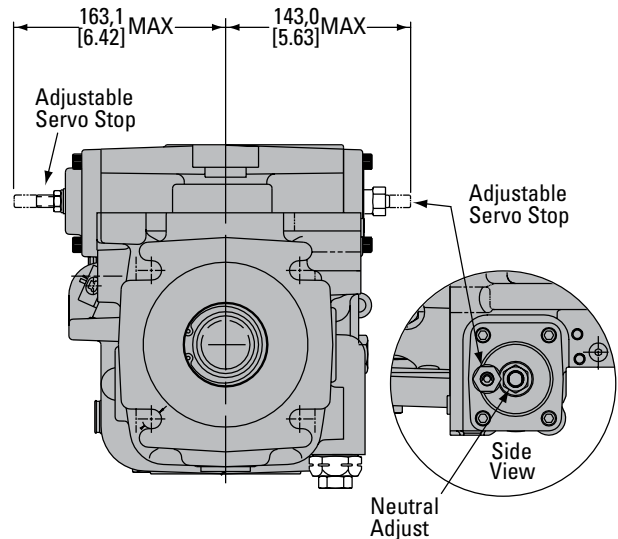

Charge Pump Options

The Series 2 Hydrostatic Pump contains an integral charge pump that may be provided with various filtration options. A standard charge pump will use suction filtration where practi-

cal. This arrangement is detailed in the diagram on page 29 and followed by the filter recommendations on page 31. For applications where suction filtration is not practical, the option below may be selected.

Remote Filter Ports (Optional) Model Code A in Position 26

Remote pressure filter ports allow you to mount a pressure side filter in a more easily accessible

location. The filter ports accept 7/8-14 UNF-2B SAE O-ring fittings. The filter and lines must be able to withstand pressures up to 70 bar (1000 psi).

Control Options – Manual Control

Model Code Positions 18 & 19

The wide variety of available controls on the Eaton® Heavy Duty Series 2 Pump offers vehicle designers the control necessary for optimal vehicle performance. Many of these controls are combined as single control options; please refer to the model code for the specific option configuration. For combinations other than shown, contact an Eaton representative.

Standard Manual Displacement Control (MA)

The standard manual displacement control, the most common control option, typically connects

directly with mechanical linkages or cables.

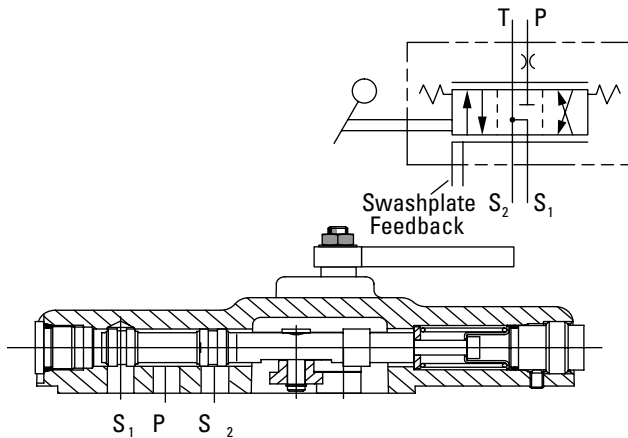

Manual Control with Neutral Lockout (MB)

The neutral lock-out feature is an electrical switch that is closed or open when the transmission is in neutral. This switch can be used to prevent the activation of certain functions that require the pump to be in

neutral. The lock-out feature is commonly used to prevent starting the prime mover or activating auxiliary functions. The electrical switch is available as normally open or normally closed.

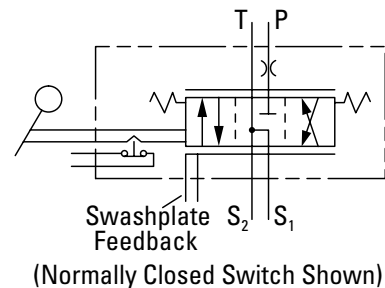

Manual Displacement Control with Wide Band Neutral Detent (ML)

This control is the same as the above with an increased neutral band.

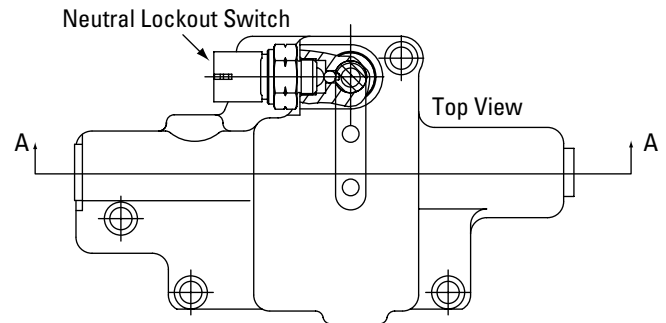

Manual Control with Neutral Detent (MC)

The neutral detent feature provides a more positive feel when finding neutral. This option is ideal for transmissions with long

control linkages or cables, or in other situations where there is a great deal of space between the operator station and the pump.

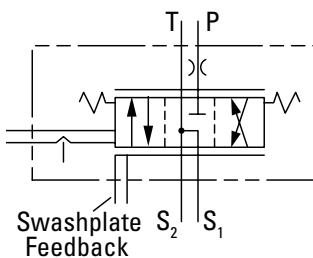
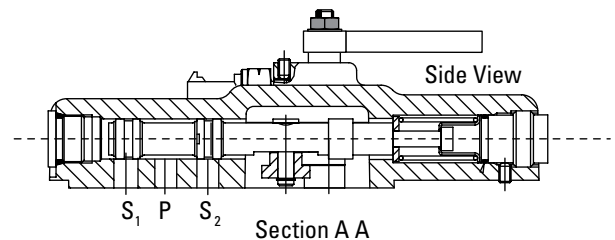

Mating Connector for MB

- Connector P/N 1201 5792 (1)
- Terminal P/N 1208 9040 (2)
- Cable Seal P/N 1201 5323 (2)
- All Part Numbers are Packard Electric

Control Options – Manual Control

Model Code Positions 18 & 19

Manual Controls – Dimensions

Displacement	Dim. A	Control Spool	Dim. B
64 cm ³ /r (3.9 in ³ /r)	18,5 (.73)	Standard	2° 30' ±1° 45'
75 cm ³ /r (4.6 in ³ /r)	18,5 (.73)	Wide Band	4° 15' ±1° 45'
89 cm ³ /r (5.4 in ³ /r)	107,3 (1.17)		
105 cm ³ /r (6.4 in ³ /r)	107,3 (1.17)		

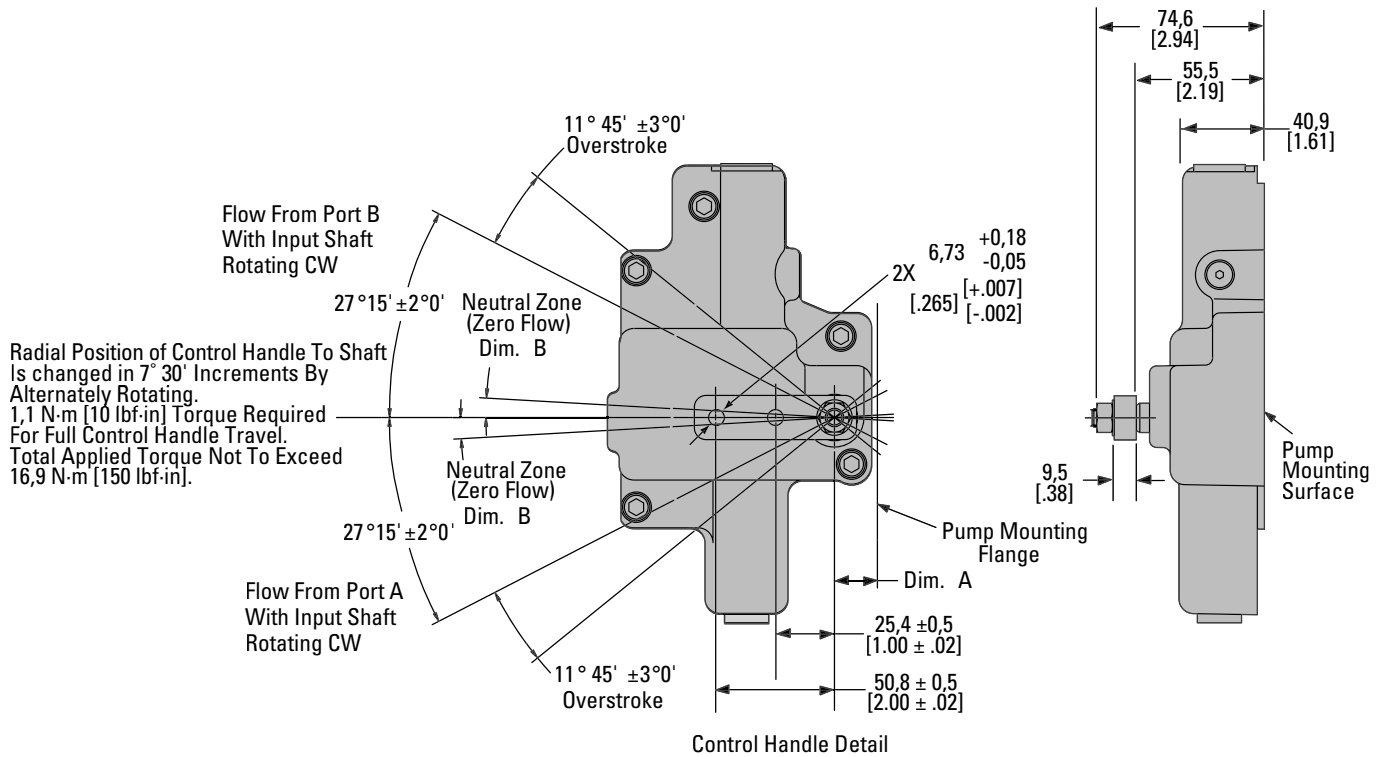

Control Options – Hydraulic Remote Control

Model Code HA in Position 18, 19

The hydraulic remote pump control makes it possible to control pump flow by changing pump displacement via a remote pilot pressure signal. The angle of the swashplate, that determines pump displacement, is proportional to the pilot pressure. Typical pressure requirements are 5-15 bar (72.5 -217.5 psi) with a swashplate angle from 0° to 18°.

The direction of flow, and therefore the direction of the vehicle, is reversed by applying the control pressure to the opposite inlet port of the hydraulic remote pump control.

The hydraulic remote pump control is readily adaptable in the following applications:

- Where remote transmission control is needed
- Where control cables or linkages are not feasible
- Where electronic controls cannot be used.

The Eaton hydraulic remote pump control is compatible with:

- All Eaton Series 2 Variable Pumps (Models 64-105)
- Other Eaton control options such as the destroke control, inching control, and pressure override
- Most commercially available hydraulic command stations

The hydraulic remote pump control is a three position, four-way closed center (spring centered) hydraulically activated servo control. This control, like the manual displacement control uses the feedback linkage connected directly to the swashplate.

The control spool is activated to position the swashplate by regulating the remote pilot pressure to the control piston. There are various manufacturers of command stations that can be used to supply this remote pilot pressure.

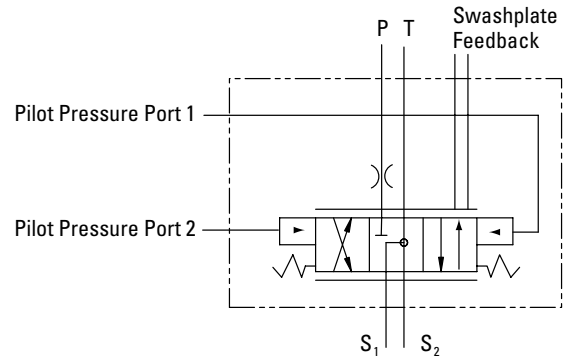

Hydraulic Remote Control

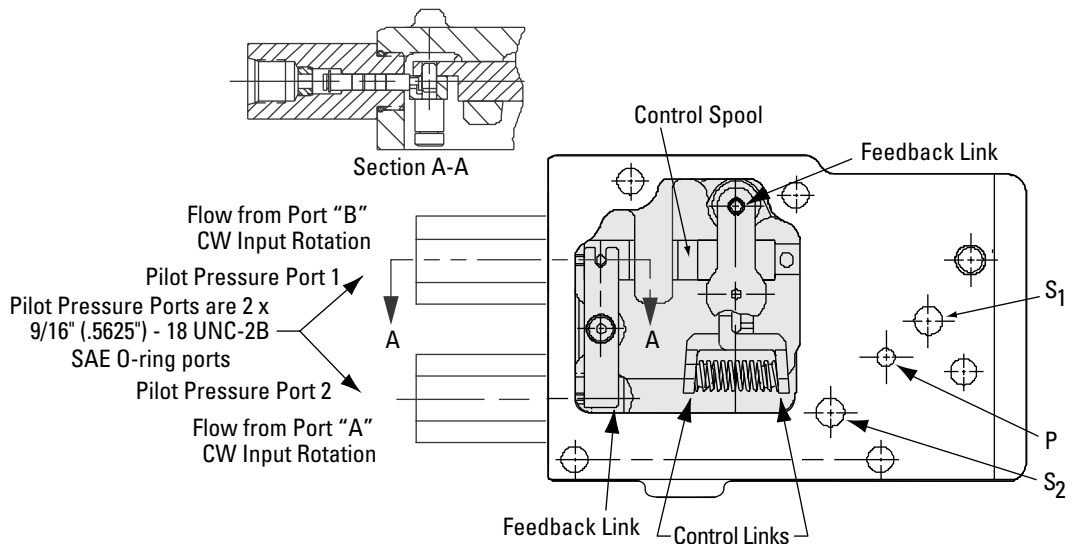

Control Options – Electronic Proportional Displacement Control

Model Code EC & ED Position 18,19

The Electronic Proportional (EP) displacement control is ideal for applications requiring electronic pump displacement control. The EP displacement control has been designed to withstand the rigors of off-highway equipment environmental conditions.

EP Control Features

- Ease of installation
- Automotive style environmentally sealed Metri-Pack connectors
- Return to neutral for loss of power, or loss of command input signal
- Mechanical feedback of swashplate position for closed loop control
- External neutral adjustment
- Manual override capability

Matting 4 Way Connector Packard Electric**

Packard 4 Pin, Weatherpack
P/N 1218 6568 Connector,
Qty 1

P/N 1204 8074 PIN Terminal,
Qty 4

P/N 1204 8086 Cable Seal,
Qty 4

P/N 1204 7948 TPA,
Qty 1

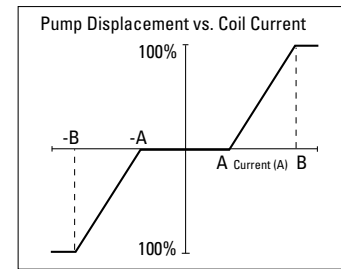
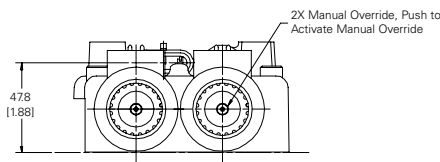
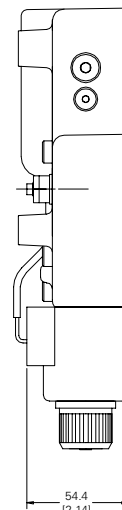
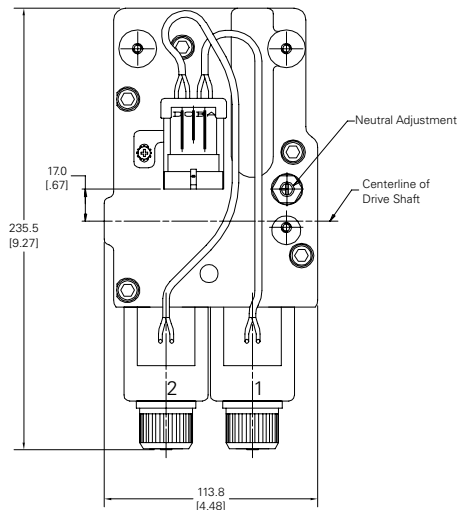
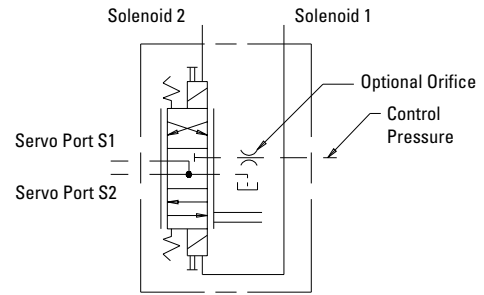
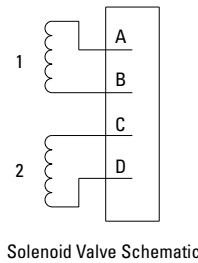

Voltage	Coil Current (A)	
	A	B
12V	0.5	1.25
24V	0.25	0.625

Note:

Coils have no internal Diodes. A-B Polarity and C-D Polarity Does Not affect operation

Modulation frequency flange for optimal performance is 75-200 Hz

Pin	Color	Signal
A	Yellow	Coil 1 PWM
B	White	Coil 1 Return
C	Orange	Coil 2 PWM
D	Black	Coil 2 Return

Input Shaft Rotation

	CCW		CW	
	1	2	1	2
Solenoid Energized	1	2	1	2
Port A Flow	Out	In	In	Out
Port B Flow	In	Out	Out	In

Proportional Valve Specification	EC	ED	Typical E Electronic Controller
Voltage	12 VDC	24 VDC	
Resistance	5.2 Ohms	20.8 Ohms	
Inductance	70 mH	277 mH	
Current	1500 mA	750 mA	
Threshold Current	200-600 mA	100-300 mA	
PWM Frequency*	70-200 Hz	70-200 Hz	
Dither Frequency	75 Hz	75 Hz	
Dither Amplitude	250 mA	125 mA	
Ambient Temperature	-65°F to 140°F (-54°C to 60°C)		
Coil Impedance	10 mH	42 mH	

* 100 Hz recommended when PWM driver does not have built-in dither capabilities

** Contact Eaton for other connector styles

Contact Eaton for TCA, Maestro, and EFX controller available from Eaton; or customer supplied controller.

PWM configuration: Closed loop current control (12/24 volts DC voltage cannot be applied to coil without exceeding continuous rated current)

Control Options – Solenoid Control with Swashplate Feedback Sensor

Model Code SE in Position 18, 19

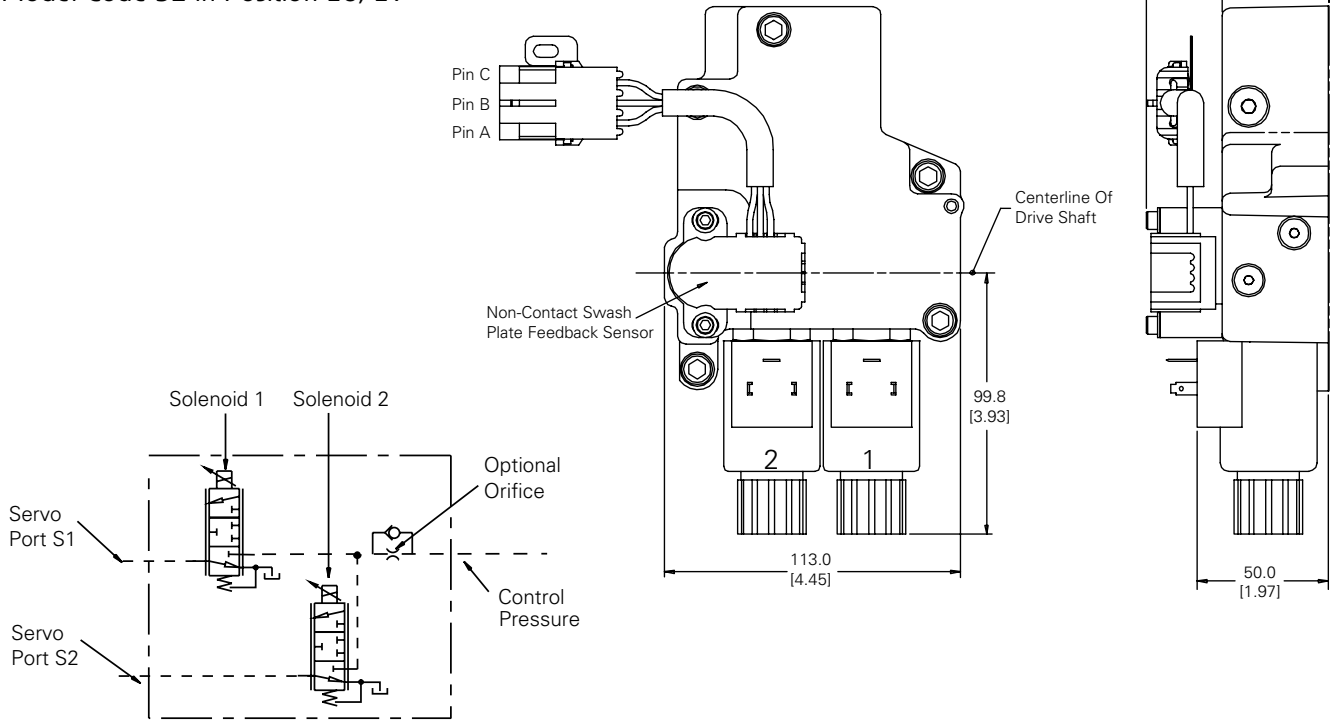

Sensor Connector

Pin	Wire Color	Function
A	Black	Return
B	Blue	V Out (Signal)
C	Red	+ 5 VDC

Mating Connector for Valve**

DIN 43650, Form A (IP65)
(Deutsch connector available upon request)

Mating Connector for Sensor (IP66)

Packard 3 Pin Weatherpack
P/N 12015793, Connector Qty 1
P/N 12089188, PIN Terminal, Qty 3
P/N 12015323, Cable Seal, Qty 3

** Contact Eaton for other connector styles

% Servo Piston Flow vs Valve Coil Current

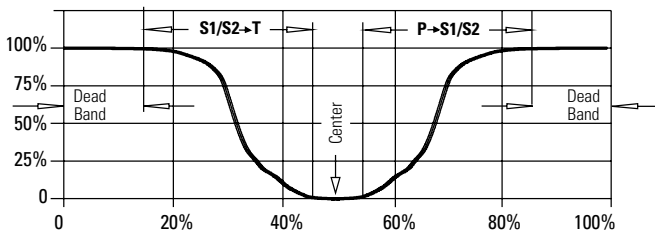

Input Shaft Rotation

	CCW		CW	
Solenoid Energized	1	2	1	2
Port A Flow	Out	In	In	Out
Port B Flow	In	Out	Out	In

Swashplate Sensor Electrical Data

Supply Voltage	5±0.50 VDC
Supply Current	10mA
Sensor Gain	10°/V, CW Shaft rotation increases output
Angle Sweep	-20° at 0.5V; +20° at 4.5V; 0° (pump neutral) at 2.5V
Max Output Error*	±3%

*Error includes thermal linearity, and sensitivity drift

Valve Specifications	SE	SG	Typical Electronic Controller
Voltage	12 VDC	24 VDC	Contact Eaton for Fx controllers or customer supplier controller.
Resistance	4.0 Ohms	16.0 Ohms	
Inductance	12.3 mH	49.4 mH	
Current	1750 mA	875 mA	
Ambient Temp	-65°F to 140°F (-54°C to 60°C)		

Control Options – Forward - Neutral - Reverse Control

Model Code FR, FS in Position 18, 19

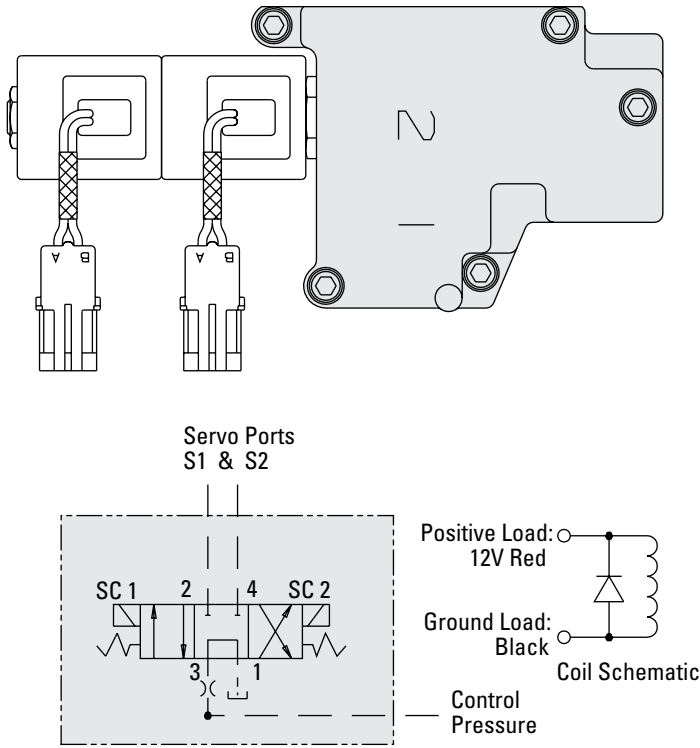

Control Special Features – Destroke Valve

Model Code 3 in Position 23

The destroke solenoid valve, when activated, causes the pump to destroke and go to zero displacement. This valve may be used as a safety device. Typically, the valve is activated by a seat switch detecting operator presence or by a remote emergency stop switch on the operator's console. It is available in 12 or 24 Vdc and either normally open or normally closed configurations.

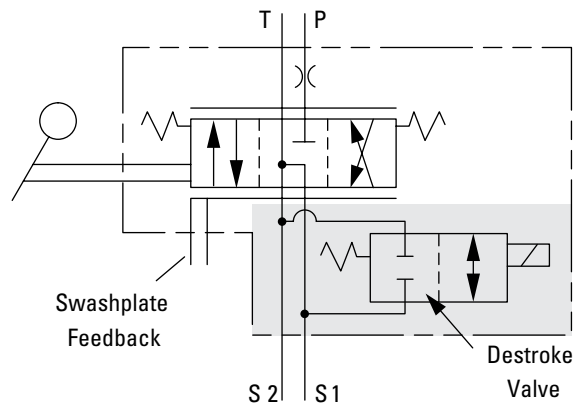

Pump Dimensions – Opposite Side Porting

Model Code 64, 75

64 cm³/r (3.9 in³/r)

75 cm³/r (4.6 in³/r)

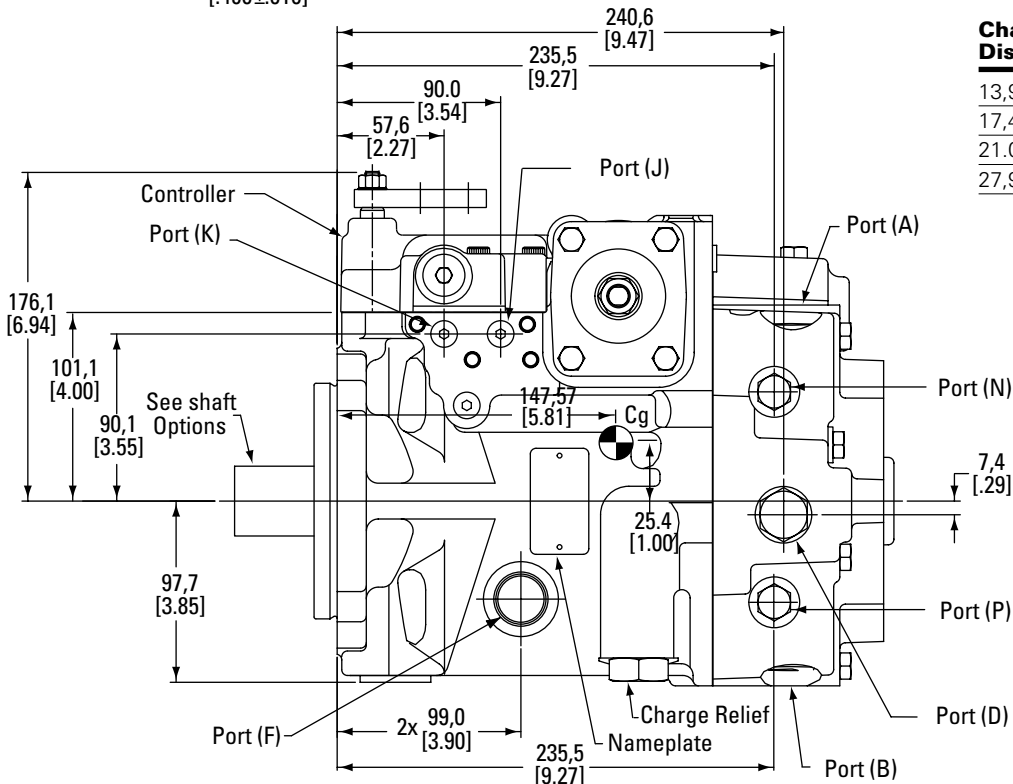
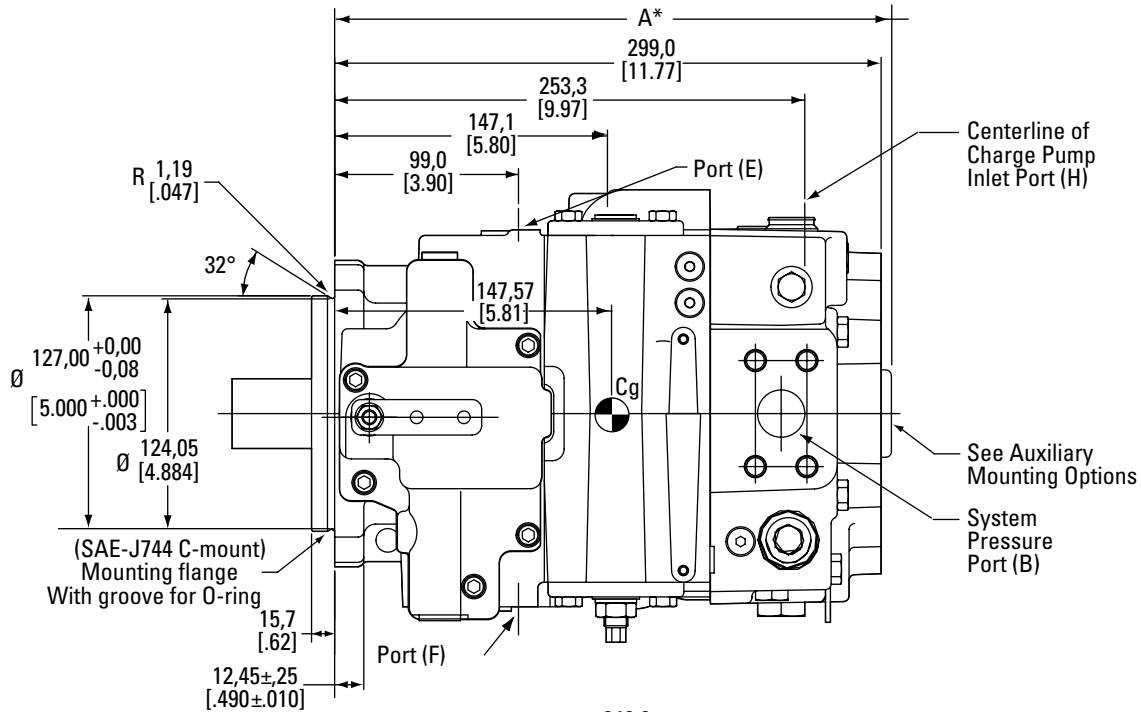

Charge Pump Displacement	*A Dimension
13,9 cm ³ /r (.85 in ³ /r)	300,3 (11.82)
17,4 cm ³ /r (1.06 in ³ /r)	303,7 (11.96)
21,0 cm ³ /r (1.28 in ³ /r)	307,2 (12.10)
27,9 cm ³ /r (1.70 in ³ /r)	314,1 (12.37)

Pump Dimensions – Opposite Side Porting

Model Code 64, 75

64 cm³/r (3.9 in³/r)

75 cm³/r (4.6 in³/r)

Optional Magnetic
Speed Sensor
Mating 2 Way Connector
Connector p/n 1216 2163 (1)
Pin Terminal p/n 121 4075 (2)
Cable Seal p/n 1204 8086 (2)
All part numbers are Packard Electric

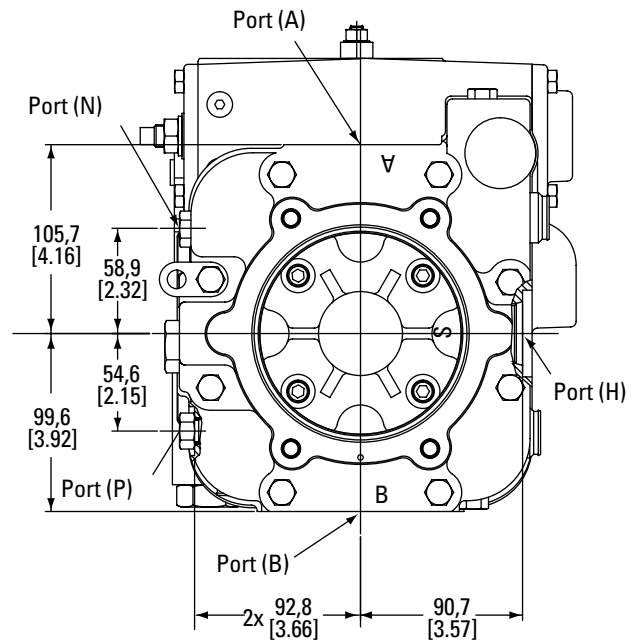
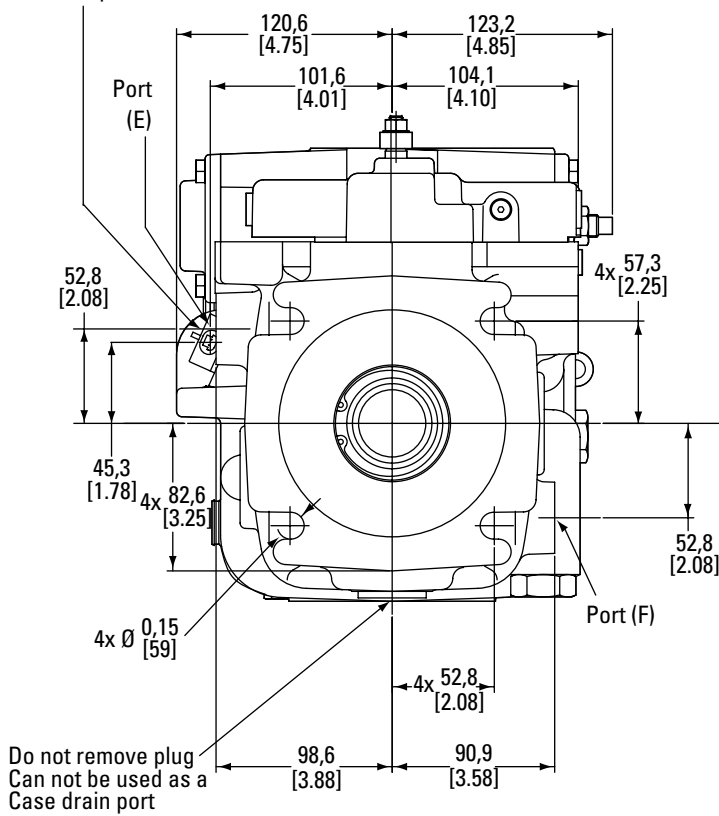

Weight

58 kg (128 lbs.)

Port Description S.A.E. O-ring Port Size

Port	Description	S.A.E. O-ring Port Size
A	Main Port	1" per Code 61 per J518
B	Main Port	1" per Code 61 per J518
D	Charge Gauge Port	7/8-14 UN-2B
E	Case Drain Port	1-1/16-12 UN-2B
F	Case Drain Port	1-1/16-12 UN-2B
H	Charge Pressure Inlet Port	1-5/16-12 UN-2B
P	Gauge Port, System Port B	9/16-18 UNF-2B
N	Gauge Port, System Port A	9/16-18 UNF-2B
J	Gauge Port Servo 1	7/16-20 UNF-2B
K	Gauge Port Servo 2	7/16-20 UNF-2B

Pump Dimensions – Same Side Porting

Model Code 64, 75

64 cm³/r (3.9 in³/r)

75 cm³/r (4.6 in³/r)

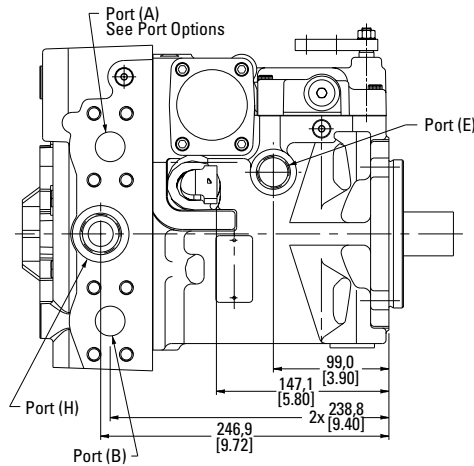
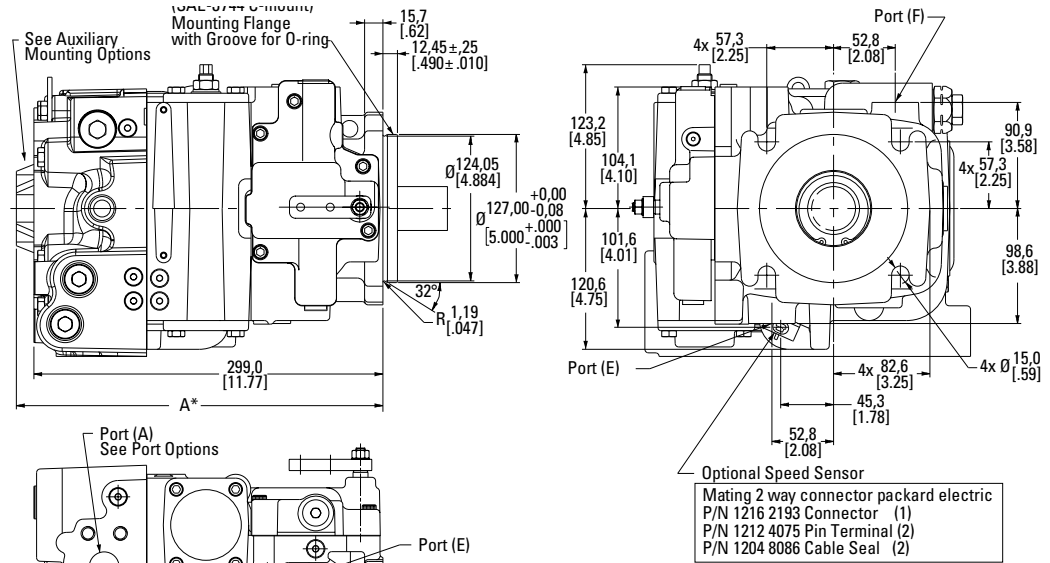

Charge Pump Displacement	*A Dimension
13,9 cm ³ /r (.85 in ³ /r)	300,3 (11.82)
17,4 cm ³ /r (1.06 in ³ /r)	303,7 (11.96)
21,0 cm ³ /r (1.28 in ³ /r)	307,2 (12.10)
27,9 cm ³ /r (1.70 in ³ /r)	314,1 (12.37)

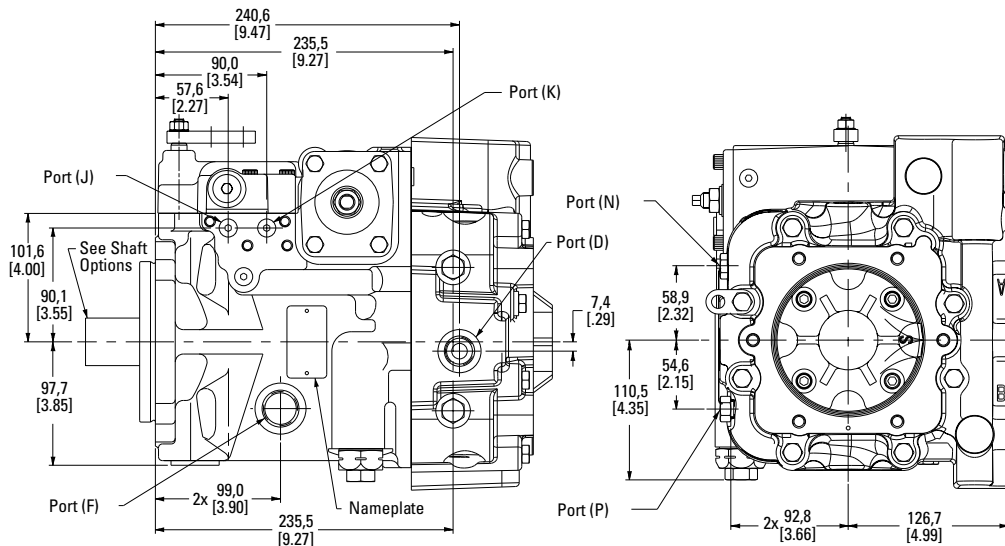

Port	Description	S.A.E. O-ring Port Size
A	Main Port	1" per Code 61 per J518
B	Main Port	1" per Code 61 per J518
D	Charge Gauge Port	7/8-14 UN-2B
E	Case Drain Port	1-1/16-12 UN-2B
F	Case Drain Port	1-1/16-12 UN-2B
H	Charge Pressure Inlet Port	1-5/16-12 UN-2B
P	Gauge Port, System Port B	9/16-18 UNF-2B
N	Gauge Port, System Port A	9/16-18 UNF-2B
J	Gauge Port Servo 1	7/16-20 UNF-2B
K	Gauge Port Servo 2	7/16-20 UNF-2B

Pump Dimensions – Opposite Side Porting

Model Code 89, 105

89 cm³/r (5.4 in³/r)

105 cm³/r (6.4 in³/r)

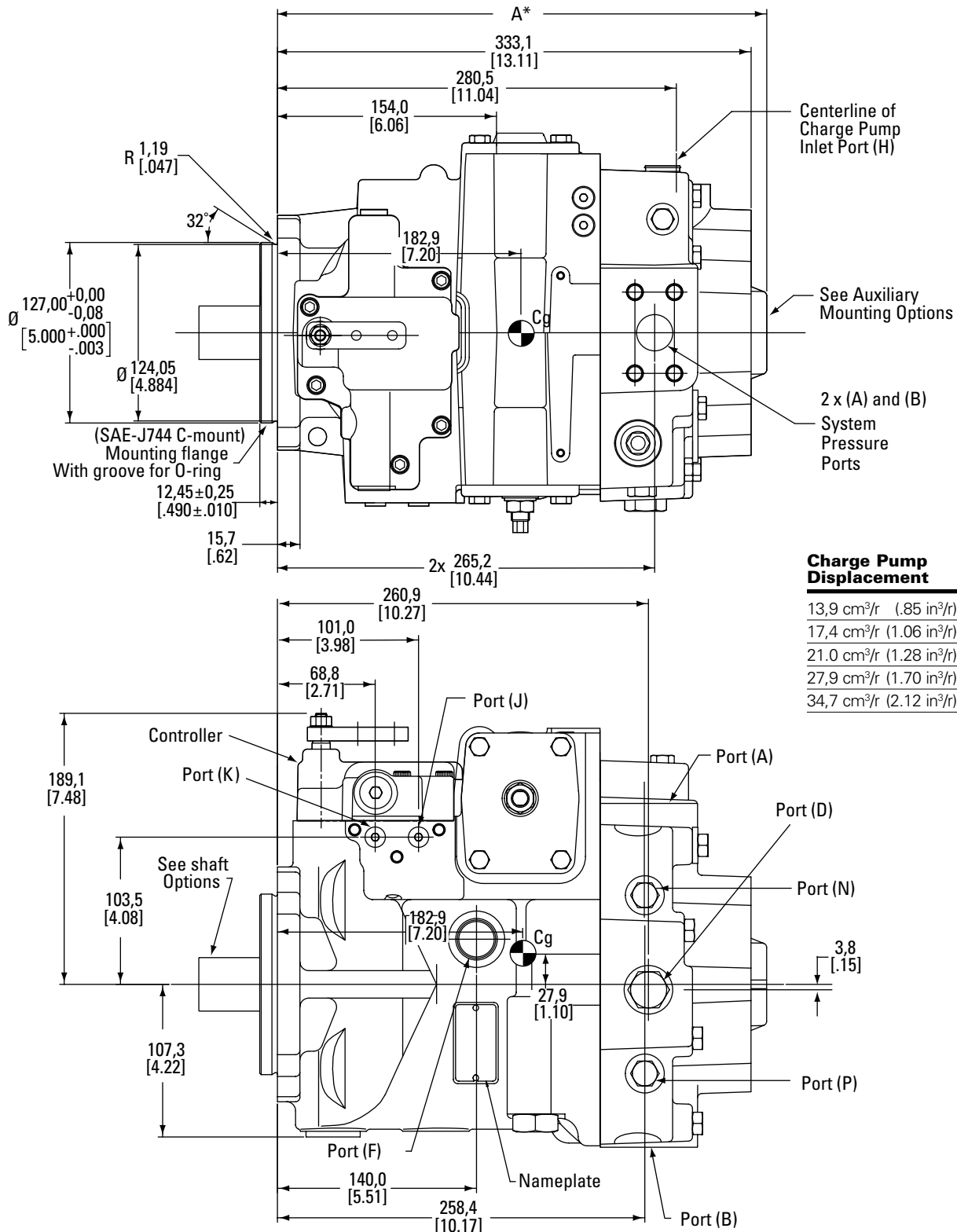

Charge Pump Displacement	*A Dimension
13,9 cm ³ /r (.85 in ³ /r)	337,1 (13.27)
17,4 cm ³ /r (1.06 in ³ /r)	340,5 (13.40)
21,0 cm ³ /r (1.28 in ³ /r)	344,0 (13.55)
27,9 cm ³ /r (1.70 in ³ /r)	350,9 (13.81)
34,7 cm ³ /r (2.12 in ³ /r)	357,7 (14.08)

Pump Dimensions – Opposite Side Porting

Model Code 89, 105

89 cm³/r (5.4 in³/r)

105 cm³/r (6.4 in³/r)

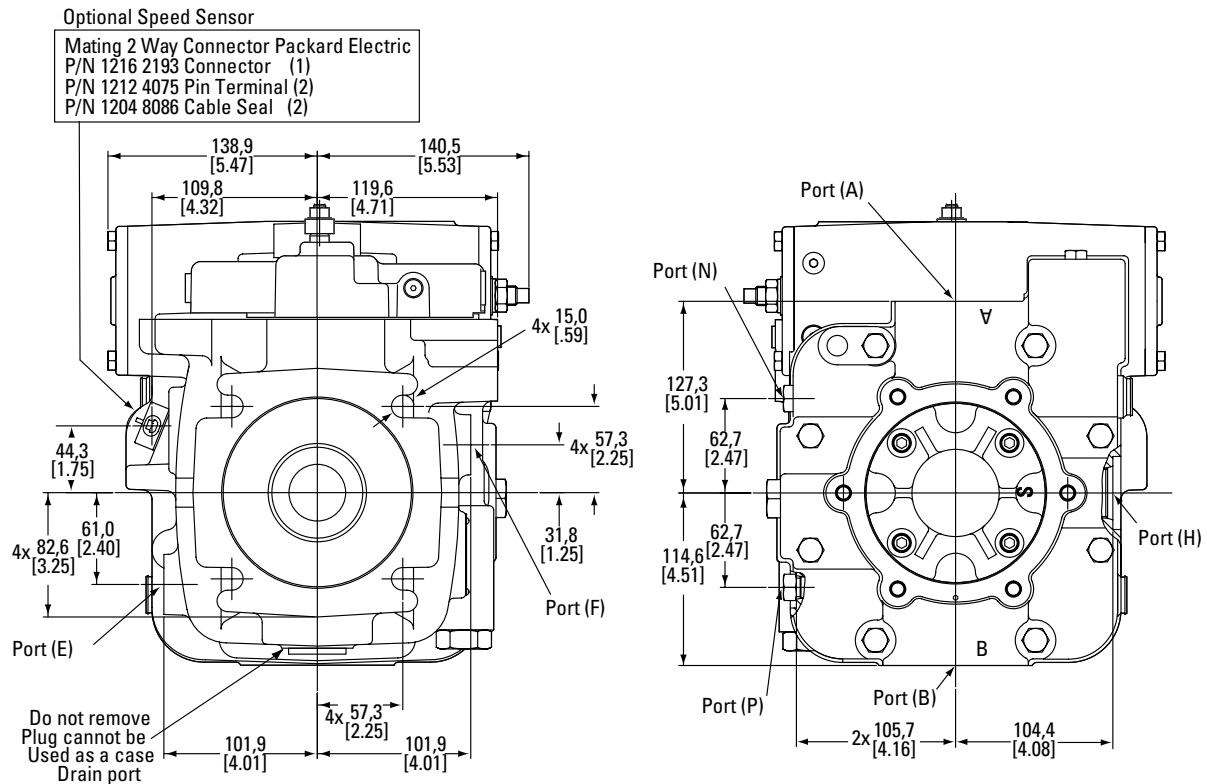

Weight

81 kg (178 lbs.)

Port	Description	S.A.E. O-ring Port Size
A	Main Port	1" per Code 61 per J518
B	Main Port	1" per Code 61 per J518
D	Charge Gauge Port	7/8-14 UN-2B
E	Case Drain Port	1-1/16-12 UN-2B
F	Case Drain Port	1-1/16-12 UN-2B
H	Charge Pressure Inlet Port	1-5/16-12 UN-2B
P	Gauge Port, System Port B	9/16-18 UNF-2B
N	Gauge Port, System Port A	9/16-18 UNF-2B
J	Gauge Port Servo 1	7/16-20 UNF-2B
K	Gauge Port Servo 2	7/16-20 UNF-2B

Pump Dimensions – Same Side Porting

Model Code 89, 105

89 cm³/r (5.4 in³/r)

105 cm³/r (6.4 in³/r)

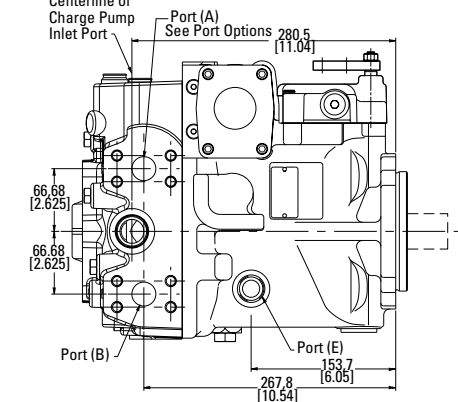
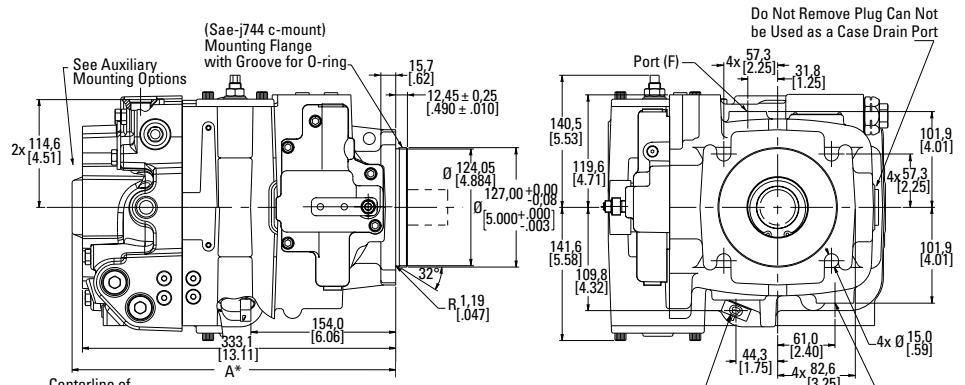

Charge Pump Displacement	*A Dimension
13,9 cm ³ /r (.85 in ³ /r)	337,1 (13.27)
17,4 cm ³ /r (1.06 in ³ /r)	340,5 (13.40)
21,0 cm ³ /r (1.28 in ³ /r)	344,0 (13.55)
27,9 cm ³ /r (1.70 in ³ /r)	350,9 (13.81)
34,7 cm ³ /r (2.12 in ³ /r)	357,7 (14.08)

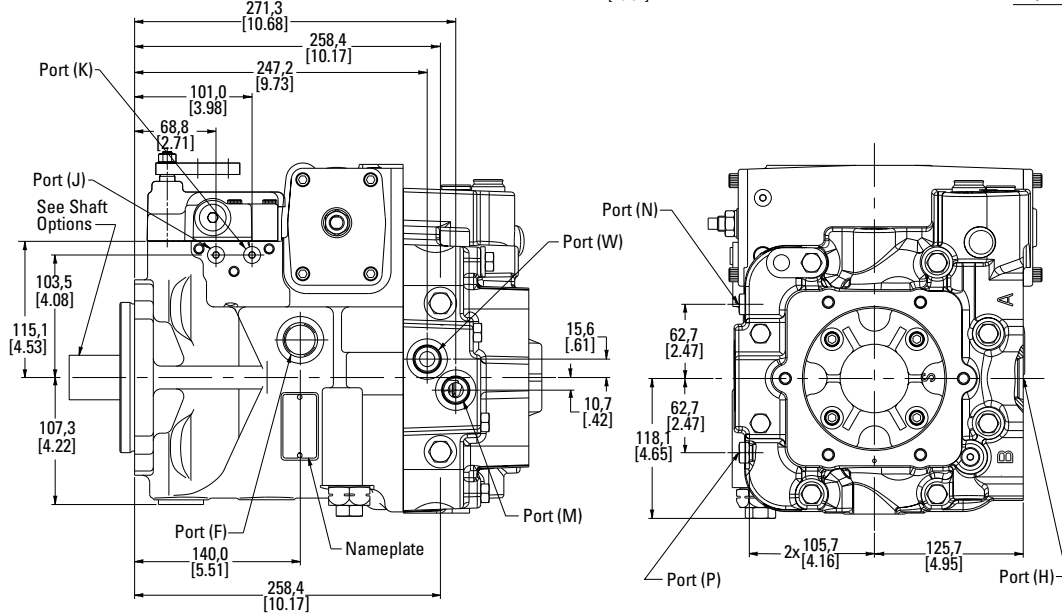

Port	Description	S.A.E. O-ring Port Size
A	Main Port	1" per Code 61 per J518
B	Main Port	1" per Code 61 per J518
D	Charge Gauge Port	7/8-14 UN-2B
E	Case Drain Port	1-1/16-12 UN-2B
F	Case Drain Port	1-1/16-12 UN-2B
H	Charge Pressure Inlet Port	1-5/16-12 UN-2B
P	Gauge Port, System Port B	9/16-18 UNF-2B
N	Gauge Port, System Port A	9/16-18 UNF-2B
J	Gauge Port Servo 1	7/16-20 UNF-2B
K	Gauge Port Servo 2	7/16-20 UNF-2B
M	Remote Filter Port, Connect to Filter Outlet (Charge Pump Return)	7/8-14 UN-2B
W	Remote Filter Port, Connect to Filter Inlet (Charge Pump Outlet)	7/8-14 UN-2B

Input Shaft Options

Model Code Position 7, 8

Model Code 02 - 23 Tooth

Torque: 1469 N·m (13.000 lbf·in)

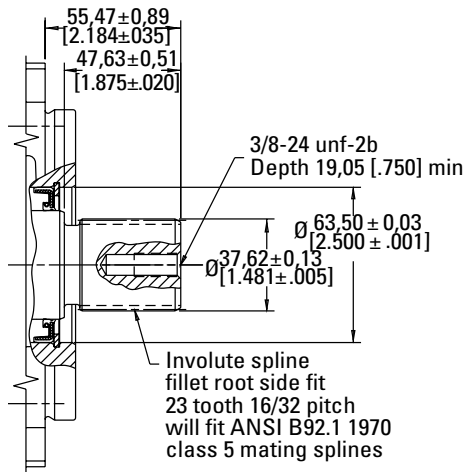

Model Code 03 - 1.50 Tapered

Torque: 836 N·m (7.400 lbf·in)

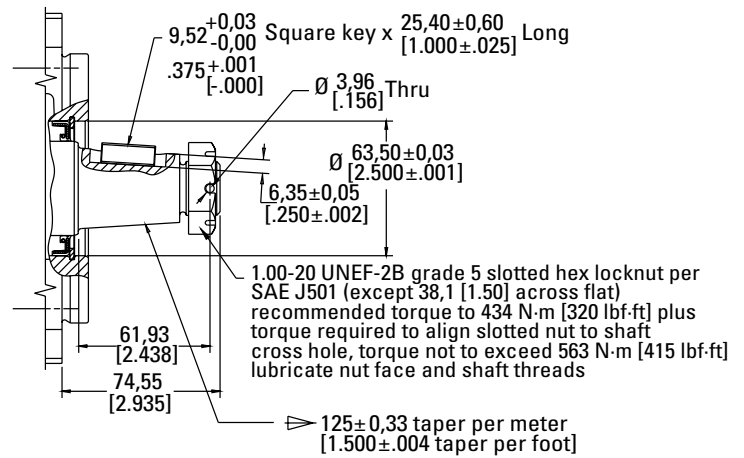

Model Code 13 - 13 Tooth

Torque: 1921 N·m (17.000 lbf·in)

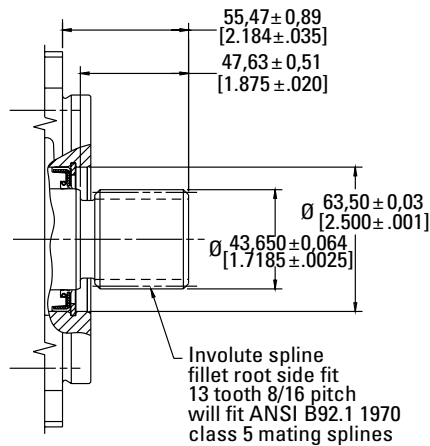

Model Code 14 - 14 Tooth

Torque: 791 N·m (7.000 lbf·in)

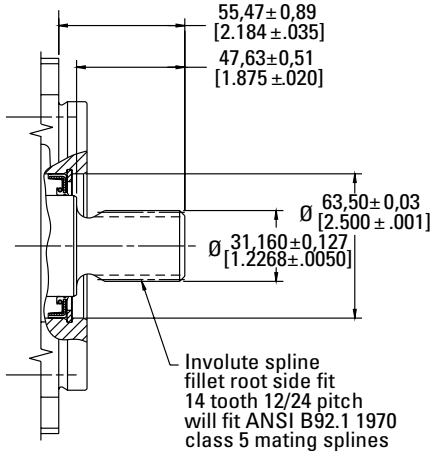

Model Code 21 - 21 Tooth

Torque: 1130 N·m (10.000 lbf·in)

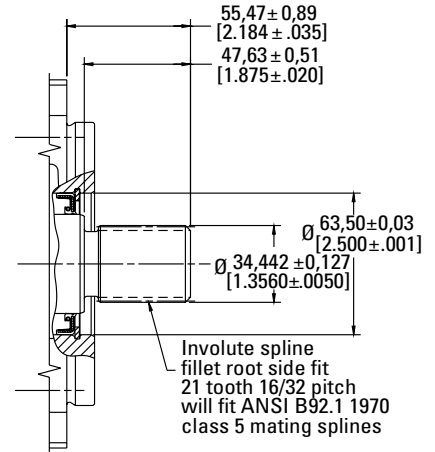

Model Code 23 - 23 Tooth

Torque: 1469 N·m (13.000 lbf·in)

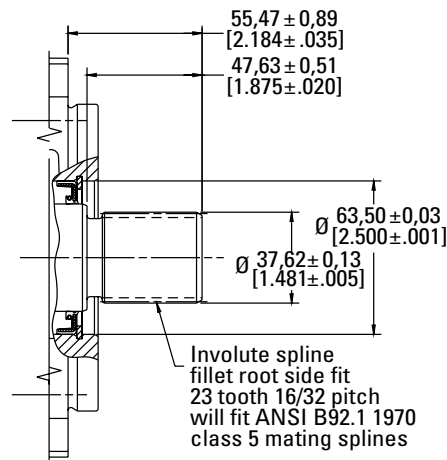

Model Code 28 - 27 Tooth

Torque: 734 N·m (6.500 lbf·in)

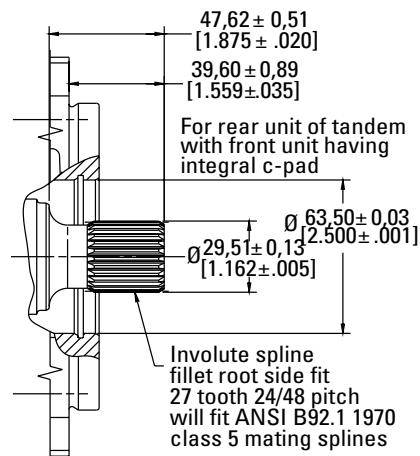

Auxiliary Mount Options

Position 25

Model Code C - A-pad adapter with 9 tooth
Torque: 113 N·m (1.000 lbf·in)

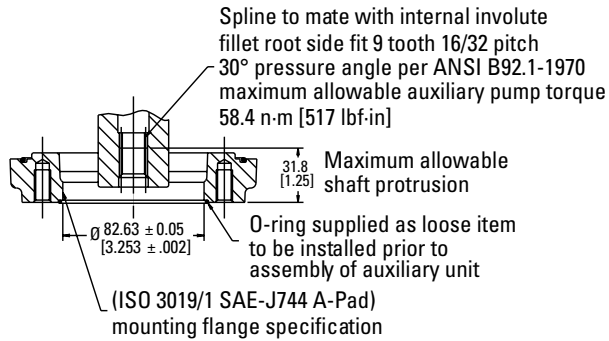

Section A-A

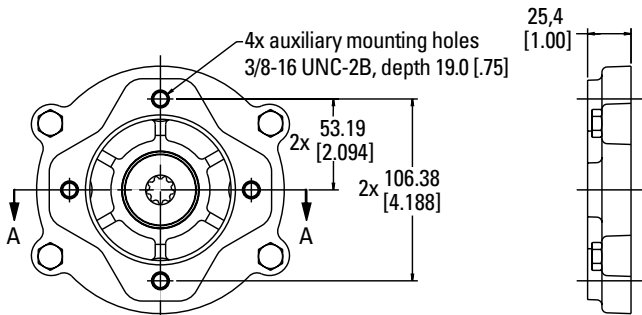

Model Code K - A-pad adapter with 11 tooth
Torque: 170 N·m (1.500 lbf·in)

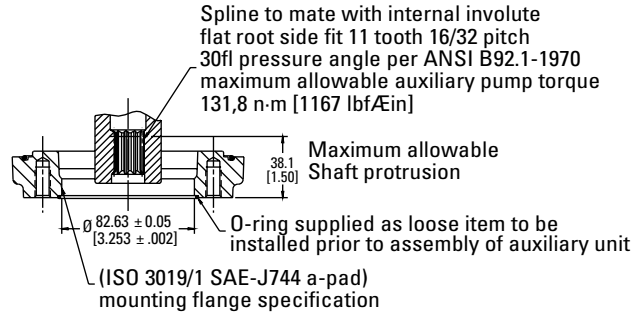

Section B-B

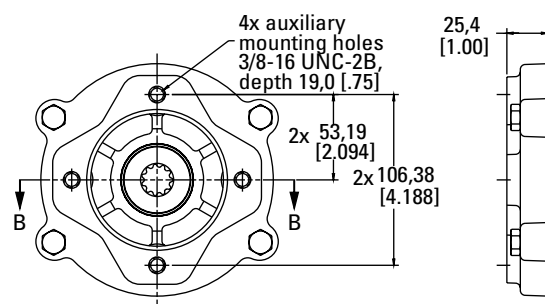

Model Code D - B-pad adapter with 13 tooth
Torque: 283 N·m (2.500 lbf·in)

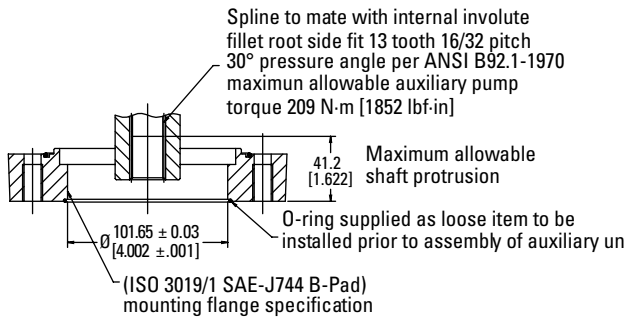

Section C-C

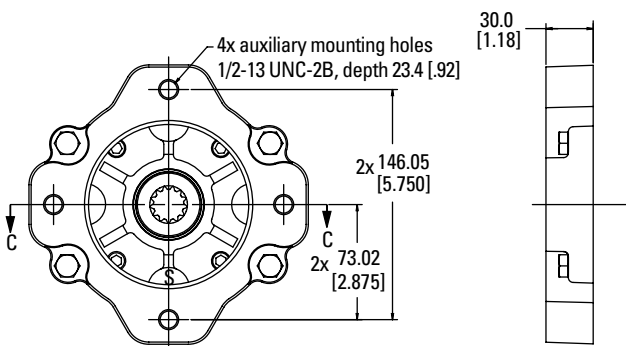

Model Code E - B-B pad adapter with 15 tooth
Torque: 407 N·m (3.600 lbf·in)

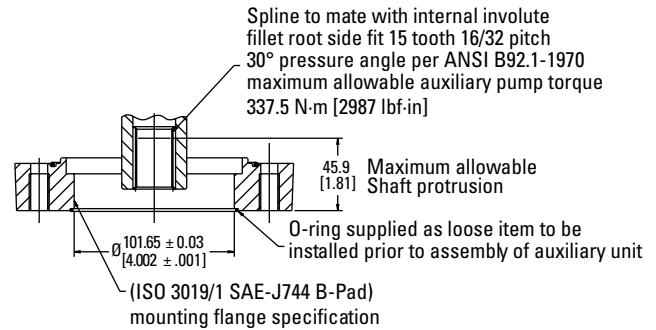

Section D-D

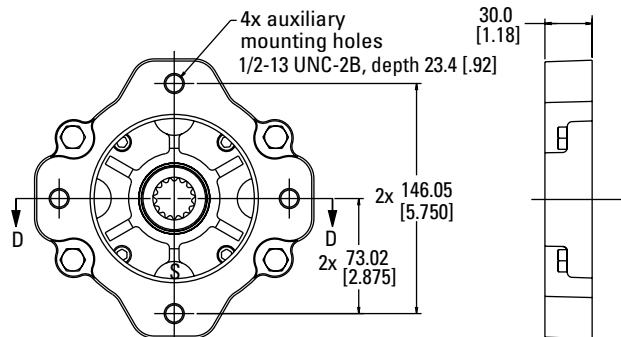

Auxiliary Mount Options

Position 25

Model Code F - C-pad adapter with 14 tooth and charge pump
Torque: 701 N·m (6.200 lbf·in)

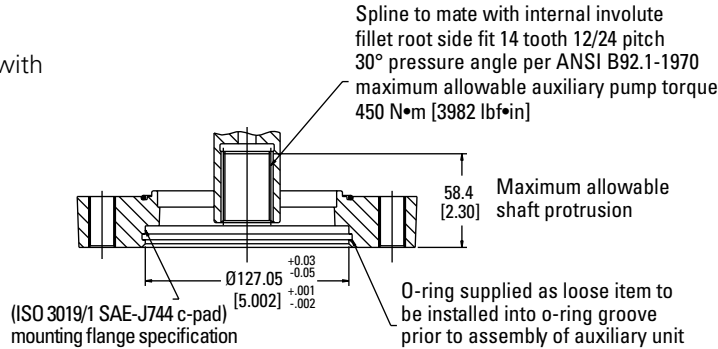

Section E-E

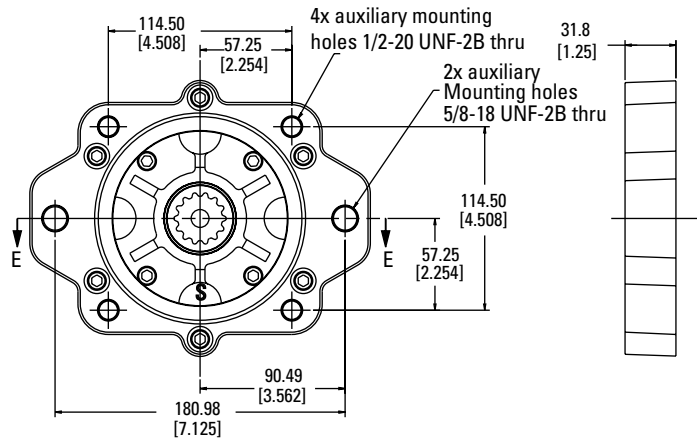

Model Code H - C-pad mount with 27 tooth w/out charge pump
Torque: 814 N·m (7.200 lbf·in)

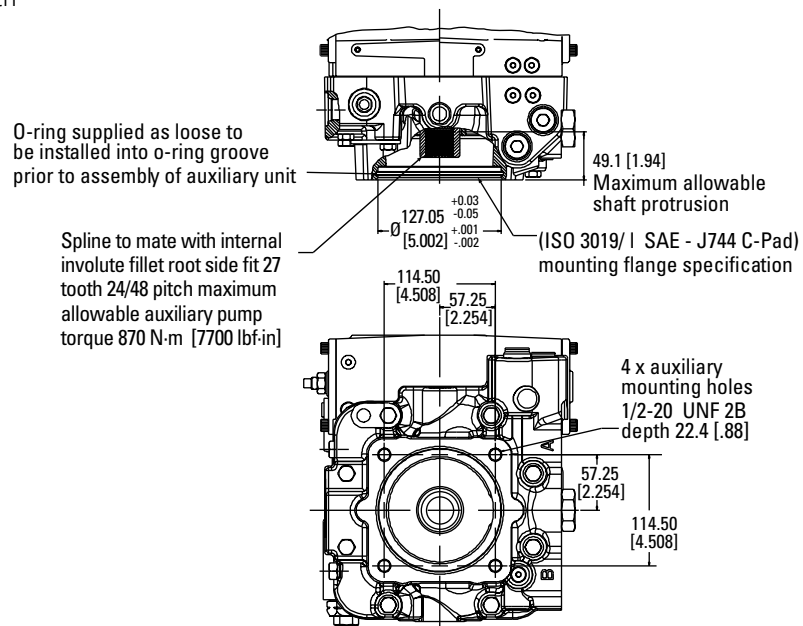

Operational Diagram

Typical Series 2 Variable Displacement Pump/Fixed Displacement Motor Schematic

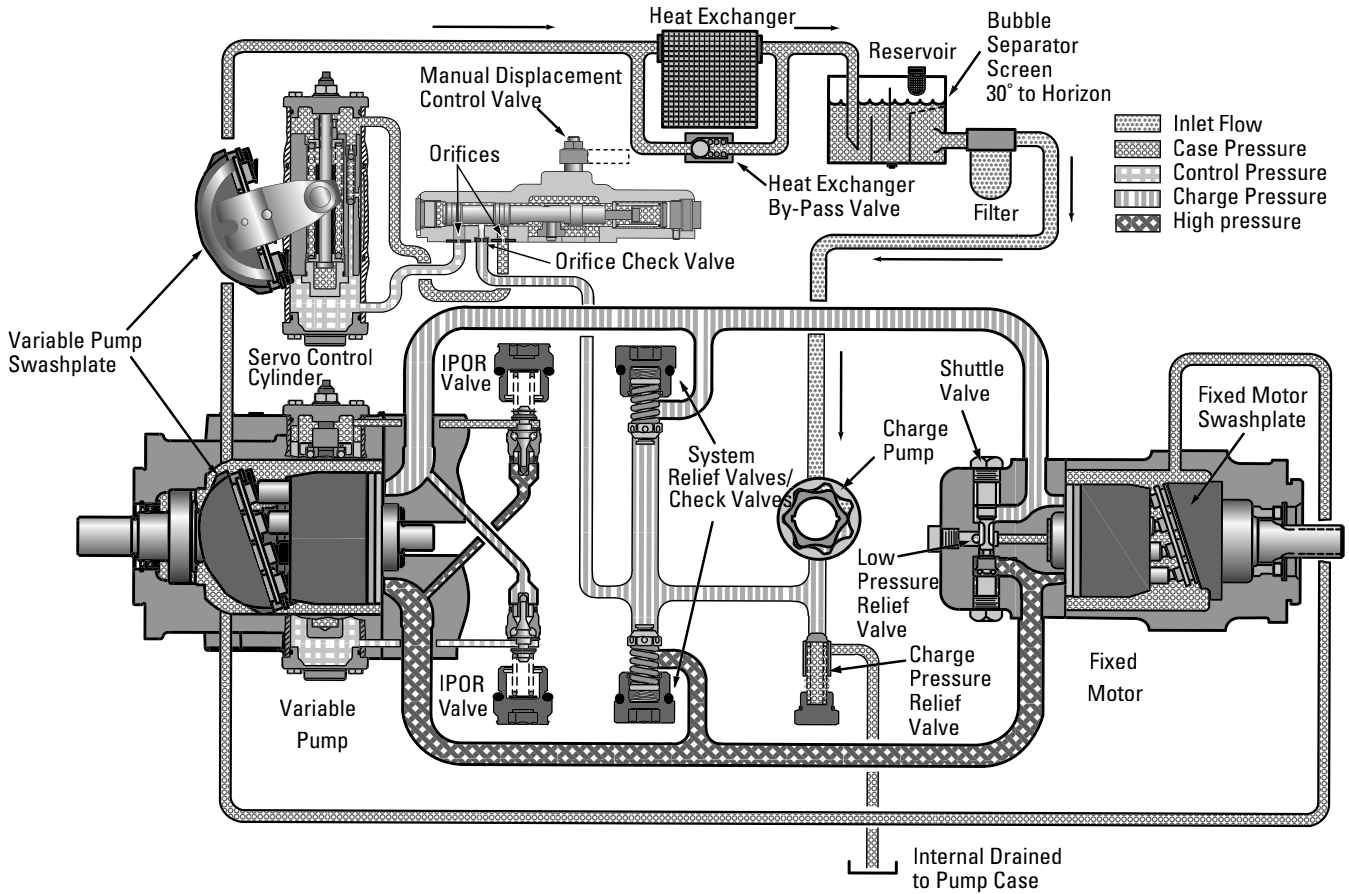

Note:

For ease of viewing, the Servo Control Cylinder, Swashplate, and Control Valve are shown removed from the pump.

Application Information

Component Descriptions

The operational diagram on page 29 shows a typical heavy duty hydrostatic transmission. The axial piston pump and axial piston motor are the main components. The filter, reservoir, heat exchanger, and oil lines make up the rest of the system. The function of each of these components is described below:

A separate energy source, such as an electric motor or internal combustion engine, turns the input shaft of the pump.

Variable Displacement Axial Piston Pump

The variable displacement pump provides a flow of high pressure oil. Pump output flow can be varied to obtain the desired motor output speed. For example, when the pump's displacement is zero, no oil is pumped and the transmission's motor output shaft is stopped. Conversely, maximum pump displacement produces maximum motor shaft speed. The direction of high pressure flow can also be reversed; doing so reverses the direction the motor output shaft rotates.

A charge pump is integrated into the piston pump and driven by the shaft of the piston pump. The drawing illustrates a suction filtration circuit. Eaton recommends a suction filter without a bypass valve. The charge pump has a Low Pressure Relief Valve that regulates the output pressure.

Eaton's Series 2 Pump offers High Pressure Relief Valves and Pressure

Override Control for system high pressure protection. (see page 29 for a description of these features).

Fixed Displacement Axial Piston Motor

The motor uses the high pressure oil flow from the pump to produce transmission output. The high pressure oil comes to the motor through one of the high pressure lines. It enters the motor, turns the output shaft, then returns to the pump. Eaton piston motors integrate an hot oil shuttle and low pressure relief valve into the end cover. The shuttle valve and low pressure relief valve direct excess charge pump flow into the motor case. The shuttle valve is activated by high pressure and directs excess charge pump flow over the low pressure relief valve. This flushing action allows the charge pump to provide clean, cool oil to the closed loop circuit.

Reservoir

The reservoir is an important part of the hydrostatic transmission system. It should provide adequate oil storage and allow easy oil maintenance.

The reservoir must hold enough oil to provide a continuous oil supply to the charge pump inlet. It must also have enough room for the hydraulic oil to expand as the system warms up. Consider charge pump flow when sizing the reservoir: One half (.5) minute times (X) the maximum charge pump flow should be the minimum oil volume in the

reservoir. Maintaining this oil volume will give the oil a minimum of thirty (30) seconds in the reservoir. This will allow any entrained air to escape and contamination to settle out of the oil.

To allow for oil expansion, the reservoir's total volume should be at least six tenths (.6) minute times (X) the maximum charge pump flow.

The reservoir's internal structure should cut down turbulence and prevent oil aeration.

The line returning flow to the reservoir should be fitted with a diffuser to slow the incoming oil to 1 to 1.2 meters (3-4 feet) per second to help reduce turbulence. The return flow line should also be positioned so that returning oil enters the reservoir below the liquid surface. This will help reduce aeration and foaming of the oil.

The reservoir should have baffles between the return line and suction line. Baffles prevent return flow from immediately reentering the pump.

A sixty mesh screen placed across the suction chamber of the reservoir will act as a bubble separator. The screen should be placed at a thirty degree angle to the horizon.

The entrance to the suction line should be located well below the fluid surface so there is no chance of air being sucked into the charge pump inlet. However, the suction line entrance should not be located on the bottom of the reservoir where there may be a buildup of

sediment. The suction line entrance should be flared and covered with a screen.

The reservoir should be easily accessible. The fill port should be designed to minimize the possibility of contamination during filling and to help prevent over filling. There should be a drain plug at the lowest point of the reservoir and it should also have a clean-out and inspection cover so the reservoir can be thoroughly cleaned after prolonged use. A vented reservoir should have a breather cap with a micron filter.

Sealed reservoirs must be used at altitudes above 2500 feet. These reservoirs should be fitted with a two-way micron filter pressure cap to allow for fluid expansion and contraction.

In both cases the caps must be designed to prevent water from entering the reservoir during bad weather or machine washing.

A hydrostatic transmission with a well designed reservoir will run quieter, stay cleaner and last longer.

Application Information

Filter

A filter must be used to keep the hydraulic fluid clean. Either a suction filter or a pressure side filter may be used. The filter must be a no-bypass type. A suction filter is shown in the operational diagram on page 29.

System oil particulate levels should not exceed ISO 18/13. Refer to Eaton Hydraulic Fluid Recommendations on page 33.

Recommended beta ratios for each filter type are listed below:

Suction Filter
 $\beta_{10} = 1.5$ to 2.0

Pressure Side Filter
 $\beta_{10} = 10$ to 20

When a suction filter is used, its flow capacity must be large enough to prevent an excessive pressure drop between the reservoir and charge pump inlet. The pressure at the charge pump inlet port must not be less than 0.8 bar (11.6 psi) absolute at normal continuous operating temperatures.

Charge Pump Inlet Line

The inlet line to the charge pump should be large enough to keep the pressure drop between the reservoir and charge pump inlet within the limits described in the filter section. Fittings will increase the pressure drop, so their number should be kept to a minimum. It is best to keep fluid velocities below 1,25 meters (4 feet) per second.

Fluid and temperature compatibility must be considered when selecting the inlet line.

Pump and Motor Case Drain Lines

The case drain lines should be large enough to limit the pump and motor case pressures to 2,8 bar (40 psi) at normal operating temperatures. Fluid and temperature compatibility must also be considered when selecting the case drain lines.

High Pressure Lines

The high pressure lines that connect the pump and motor must be able to withstand the pressures generated in the high pressure loop.

Heat Exchanger

Use of a heat exchanger is dependent on the transmission's duty cycle and on machine layout. The normal continuous operating fluid temperature measured in the pump and motor cases should not exceed 80°C (180°F) for most hydraulic fluids. The maximum fluid temperature should not exceed 105°C (220°F).

The heat exchanger should be sized to dissipate 25% of the maximum input power available to the transmission. It must also be sized to prevent the case pressures in the pump and motor from getting too high. Case pressure up to 2.8 bar (40 psi), at normal operating temperatures, are acceptable.

Heat Exchanger Bypass Valve

The heat exchanger bypass valve is a pressure and/or temperature valve in parallel with the heat exchanger. Its purpose is to prevent case pressures from getting too high. The heat exchanger bypass valve opens when the oil is thick, especially during cold starts.

Reservoir Return Line

The same general requirements that apply to case drain lines apply to the reservoir return line.

Application Information

Shaft Couplings and Mounting Brackets

Shaft couplings must be able to withstand the torque that will be transmitted to the pump or motor. If the pump or motor is to be directly coupled to the drive, the misalignment should not exceed .050 mm (.002 in.) total indicator run-out for the combination of perpendicularity and concentricity measurements.

The hardness of the couplings connected to Eaton pump or motor shafts should be 35 Rc for tapered or straight keyed shafts and 50-55 Rc for splined shafts.

Pump Valve Plates

Eaton Heavy duty pumps may be fitted with either a V-groove valve plate or a propel valve plate. Propel valve plates should be used in applications where overrunning loads may be present.

Open Loop Circuits

Eaton heavy duty pumps and heavy duty motors may be used in open loop circuits under certain operating conditions.

Consult your Eaton representative for details.

Orientation

The mounting orientation of Eaton heavy duty pumps and motors is unrestricted. The case drain line that carries the flow leaving the pump or motor should be connected to the highest drain port on each of the units. This assures that the pump and motor cases remain full.

Multiple Pump or Motor Circuits

Multiple pumps or motors can be combined in the same circuit. When two pumps are used in a parallel circuit, their swashplate controls can be operated in phase or in sequence. The following precautions should be observed whenever multiple pumps and/or motors are connected in the same circuit:

1. Charge pump flow must be greater than the sum of the charge pump flow requirements of the individual units.
2. The possibility of motor overspeeding increases in multiple motor circuits. The parallel motor circuit will act as a frictionless differential. Should one of the motors stall the other could overspeed. The motors used in parallel circuits should, therefore, be sized to prevent overspeeding. Valves that will limit the flow to each of the motors may be used to prevent overspeeding. This will allow the use of smaller motors, however the flow limiting valves will create heat.

3. When using one pump with multiple motors, the case drain lines should be connected in series. The case flow should be routed from the most distant motor, through the remaining motors, to the pump, and finally back to the reservoir. The most distant motor should have the valve block or integral shuttle valve while the additional motors do not need a valve block or integral shuttle valve. A remote valve block is also available for multiple motor circuits. A series-parallel drain line circuit may be needed for the high case flow created in multiple pump circuits. In either case, each pump and motor should be checked for proper cooling when testing the prototype circuit.
4. Series circuits present a unique problem for axial piston motors. Pressure applied to the input port and discharge port are additive as regards to the load and life of the drive shaft and the drive shaft bearings. Please consult with your Eaton representative regarding series circuits.

Hydraulic Fluid Recommendations

Introduction

The ability of Eaton hydrostatic components to provide the desired performance and life expectancy depends largely on the fluid used. The purpose of this document is to provide readers with the knowledge required to select the appropriate fluids for use in systems that employ Eaton hydrostatic components.

One of the most important characteristics to consider when choosing a fluid to be used in a hydraulic system is viscosity. Viscosity choice is always a compromise; the fluid must be thin enough to flow easily but thick enough to seal and maintain a lubricating film between bearing and sealing surfaces. Viscosity requirements for Eaton's Heavy Duty Hydrostatic product line are specified later in this document.

Viscosity and Temperature

Fluid temperature affects viscosity. In general, as the fluid warms it gets thinner and its viscosity decreases. The opposite is true when fluid cools. When choosing a fluid, it is important to consider the start-up and operating temperatures of the hydrostatic system. Generally, the fluid is thick when the hydraulic system

is started. With movement, the fluid warms to a point where the cooling system begins to operate. From then on, the fluid is maintained at the temperature for which the hydrostatic system was designed. In actual applications this sequence varies; hydrostatic systems are used in many environments from very cold to very hot. Cooling systems also vary from very elaborate to very simple, so ambient temperature may affect operating temperature. Equipment manufacturers who use Eaton hydrostatic components in their products should anticipate temperature in their designs and make the appropriate fluid recommendations to their customers.

In general, an ISO viscosity grade 68 fluid is recommended for operation in cold to moderate climates. An ISO viscosity grade 100 fluid is recommended for operation in moderate to hot climates.

Cleanliness

Cleanliness of the fluid in a hydrostatic system is extremely important. Eaton recommends that the fluid used in its hydrostatic components be maintained at ISO Cleanliness Code

18/13 per SAE J1165. This code allows a maximum of 2500 particles per milliliter greater than 5 mm and a maximum of 80 particles per milliliter greater than 15 mm. When components with different cleanliness requirements are used in the same system, the cleanest standard should be applied. OEM's and distributors who use Eaton hydrostatic components in their products should provide for these requirements in their designs. A reputable filter supplier can supply filter information.

Fluid Maintenance

Maintaining correct fluid viscosity and cleanliness level is essential for all hydrostatic systems. Since Eaton hydrostatic components are used in a wide variety of applications it is impossible for Eaton to publish a fluid maintenance schedule that would cover every situation. Field testing and monitoring are the only ways to get accurate measurements of system cleanliness. OEM's and distributors who use Eaton hydrostatic components should test and establish fluid maintenance schedules for their products. These maintenance schedules should be designed to meet the viscosity and

cleanliness requirements laid out in this document.

Fluid Selection

Premium grade petroleum based hydraulic fluids will provide the best performance in Eaton hydrostatic components. These fluids typically contain additives that are beneficial to hydrostatic systems. Eaton recommends fluids that contain anti-wear agents, rust inhibitors, antifoaming agents, and oxidation inhibitors. Premium grade petroleum based hydraulic fluids carry an ISO VG rating.

Hydraulic Fluid Recommendations

Viscosity and Cleanliness Guidelines

Product Line	Minimum	Optimum Range	Maximum	ISO Cleanliness Requirements	Comments
Heavy Duty Piston	10cSt	16 - 39 cSt	2158 cSt	18/13	
Pumps and Motors	(60 SUS)	(80 - 180 SUS)	(10,000 SUS)		

Additional Notes:

- Fluids too thick to flow in cold weather start-ups will cause pump cavitation and possible damage. Motor cavitation is not a problem during cold start-ups. Thick oil can cause high case pressures which in turn cause shaft seal problems.
- If the natural color of the fluid has become black it is possible that an overheating problem exists.
- If the fluid becomes milky, water contamination may be a problem.
- Take fluid level reading when the system is cold.
- Contact your Eaton representative if you have specific questions about the fluid requirements of Eaton hydrostatic components.

Biodegradable Oil (Vegetable) Guidelines

Product Line	Rating With Biodegradable Oil	Comments
Heavy Duty Piston	80% of normal pressure rating listed for mineral oils.	82° C (180° F) max fluid temp (unit)
Pumps and Motors		71° C (160° F) max fluid temp (reservoir)

Additional Notes:

- Viscosity and ISO cleanliness requirements must be maintained as outlined on previous page.
- Based on limited product testing to date, no reduction in unit life is expected when operating at the pressure ratings indicated above.
- Vegetable oil is miscible with mineral oil. However, only the vegetable oil content is biodegradable. Systems being converted from mineral oil to vegetable oil should be repeatedly flushed with vegetable oil to ensure 100% biodegradability.
- Specific vegetable oil products may provide normal unit life when operating at pressure ratings higher than those indicated above.
- Vegetable oils oxidize more quickly than petroleum based hydraulic fluid. Care must be taken to maintain fluid temperature within specified limits and to establish more frequent fluid change intervals.