

# Danfoss D1P Open Circuit high power axial piston pumps Service Manual



**Revision history**

*Table of revisions*

<b>Date</b>	<b>Changed</b>	<b>Rev</b>
December 2021	Updated shaft specifications drawings	0501
October 2021	Added new auxiliary mounting options, updated inlet pressure gauge port section, corrected displacement setting sections	0401
February 2021	Added angle sensor section for D1P 260	0305
June 2020	Changed document number from 'BC00000243' and 'L1426007' to 'BC157786485289' and corrected shaft descriptions	0304
June 2019	Updated Model Code chapter	0202
December 2018	Updated shaft torque specifications	0201
November 2018	Added shaft option K	0113
October 2018	Minor Update	0112
August 2018	Minor Update (Model Code)	0111
July 2018	Minor Update	0110
July 2018	Added NPNR Control	0109
June 2018	Major Update	0108
May 2018	Added units and drawing	0107
January 2017	Added Size 130	0106
September 2016	some update of drawing and numbers	0105
May 2016	Added Size 260	0104
March 2016	minor update	0103
February 2016	minor update	0102
January 2016	Converted to Danfoss layout - DITA CMS	0101
July 2015	Updated drawings	AC
April 2015	Added 145 cc information	AB
May 2014	First edition	AA

## Contents

### General Information

Overview.....	6
Features and benefits.....	6
Typical applications.....	6
Design.....	7

### Technical Specifications

Pump specifications.....	9
Fluid specifications.....	10
D1P 260 angle sensor.....	11
Angle sensor principle.....	11
Location.....	11
Angle sensor characteristics.....	12
Angle sensor electrical specifications.....	13
Angle sensor calibration.....	13
Angle sensor functionality.....	14

### Model Code

Model code.....	15
Displacement, rotation and product version.....	16
Control types.....	16
Input shaft options.....	17
Mounting flange options.....	17
End cap and main port options.....	17
Auxiliary mounting flange options.....	18
Power control settings.....	18
Pressure compensated control settings.....	19
Load sensing control settings.....	19
Hydraulic displacement control setting.....	19
Maximum and minimum displacement settings.....	19
Minimum displacement settings.....	19
Special hardware and features.....	20
Tandem pump information.....	21

### Parameters

Pressure.....	22
Speed.....	22
Performance.....	23
Input power.....	23
Output flow.....	25
Efficiency.....	26
Fluid.....	27
Viscosity.....	27
Temperature.....	27
Fluid velocity.....	27
Shaft torque ratings.....	28
Shaft load.....	28
Mounting flange loads.....	28
Auxiliary mounting pads.....	28
Estimating overhung load moments.....	29
Understanding and minimizing system noise.....	30
Installation.....	30
Filtration.....	30
Reservoir.....	31
Sizing Equations.....	31

### Control Type

NPNN (Pressure Compensated Control).....	32
NPSN (Pressure Compensated Control + Load Sensing Control).....	34
NPNR (Pressure Compensated Control + Remote Pressure Compensated Control).....	36
TPSN (Power Control + Pressure Compensated Control + Load Sensing Control).....	38

**Contents**

NNES (Electric Displacement Control + Load Sensing Control).....	40
Solenoid Specification.....	42
Standard EDC Valve.....	43
NNES Priority.....	43
TPE2/TPE5 (Power Control + Pressure Compensated Control + Electric Displacement Control).....	44
TPE2/TPE5 Priority.....	44
NPE2/NPE0 (Pressure Compensated Control + Electric Displacement Control).....	45

**Installation Drawings**

Size 130/145.....	46
Dimensions (mm) and port descriptions.....	46
Size 130/145: TPSN w/o Charge Pump.....	46
Size 130/145: TPE5 w/o Charge Pump.....	48
Size 130/145: TPSN w/ Charge pump .....	50
Size 130/145: TPE5 w/ Charge Pump.....	52
Input shaft.....	54
Shaft specifications.....	54
Aux mounting flange.....	56
Size 130/145: Option NN (No Coupling).....	56
Size 130/145: Option A1 (SAE-A, 9 teeth).....	56
Size 130/145: Option A2 (SAE-A, 11 teeth).....	57
Size 130/145: Option B1 (SAE-B, 13 teeth).....	58
Size 130/145: Option B2 (SAE-B, 15 teeth).....	58
Size 130/145: Option BA (SAE-B, 13 teeth).....	59
Size 130/145: Option C5 (SAE-C, 14 teeth).....	59
Size 130/145: Option D5 (SAE-D, 24 teeth).....	60
Size 193.....	61
Dimensions (mm) and port descriptions.....	61
Size 193: TPE2 w/ Charge Pump.....	61
Size 193: TPSN w/ Charge Pump.....	63
Input shaft.....	65
Shaft specifications.....	65
Aux mounting flange.....	68
Size 193: Option NN (No Coupling).....	68
Size 193: Option A1 (SAE-A, 9 teeth).....	68
Size 193: Option A3 (SAE-A, 13 teeth).....	69
Size 193: Option B1 (SAE-B, 13 teeth).....	69
Size 193: Option B2 (SAE-B, 15 teeth).....	70
Size 193: Option BA (SAE-B, 13 teeth) .....	71
Size 193: Option BB (SAE-B, 13 teeth).....	72
Size 193: Option C5 (SAE-C, 14 teeth).....	73
Size 193: Option C9 (SAE-C, 13 teeth).....	73
Size 193: Option D2 (SAE-D, 13 teeth).....	74
Size 193: Option D5 (SAE-D, 24 teeth).....	74
Size 193: Option E2 (SAE-E, 24 teeth).....	75
Size 260.....	76
Dimensions (mm) and port descriptions.....	76
Size 260: TPE2 w/ Charge Pump.....	76
Size 260: TPSN w/ Charge Pump.....	78
Input shaft.....	80
Shaft specifications.....	80
Aux mounting flange.....	83
Size 260: Option A1 (SAE-A, 9 teeth).....	83
Size 260: Option A3 (SAE-A, 13 teeth).....	83
Size 260: Option B1 (SAE-B, 13 teeth).....	84
Size 260: Option B2 (SAE-B, 15 teeth).....	84
Size 260: Option BA (SAE-B, 13 teeth).....	85
Size 260: Option BB (SAE-B, 13 teeth).....	86
Size 260: Option C5 (SAE-C, 14 teeth).....	87
Size 260: Option C9 (SAE-C, 13 teeth).....	88

**Contents**

Size 260: Option D2 (SAE-D, 13 teeth).....	88
Size 260: Option D5 (SAE-D, 24 teeth).....	89
Size 260: Option E2 (SAE-E, 24 teeth).....	89
Size 260: Option E3 (SAE-E, 28 teeth).....	90
Inlet pressure gauge port.....	91

**Additional Information**

Tandem with Danfoss pumps.....	93
Tandem pump torque.....	93
Tightening torque.....	94

**Installation Notes**

Below reservoir (standard).....	95
Above reservoir.....	96
Reservoir installation.....	97

**Displacement Limiter**

Displacement limiter setting.....	98
-----------------------------------	----

## General Information

### D1P overview

The D1 pump series are high performance variable axial piston pumps designed primarily for open circuit hydraulic systems used in heavy duty mobile applications.

#### Displacement options

- 130 cm<sup>3</sup> [7.93 in<sup>3</sup>]
- 145 cm<sup>3</sup> [8.85 in<sup>3</sup>]
- 193 cm<sup>3</sup> [11.78 in<sup>3</sup>]
- 260 cm<sup>3</sup> [15.87 in<sup>3</sup>]

#### Product highlights

- Maximum working pressure: 350 bar [5076 psi], peak pressure (intermittent): 400 bar [5802 psi].
- Input speed up to 2,500 rpm.

#### Control options

- Mechanical power control
- Electric power control
- Pressure compensated control
- Remote pressure compensated control
- Electric proportional displacement control
- Load sensing control

### D1P features and benefits

- Robust design for harsh conditions.
- Swashplate, servo-controlled design, with proven reliability and performance.
- Angled piston bore design improves self-priming capability.
- The spherical valve plate and cylinder block interface provide stable cylinder block rotation, thus achieving high efficiency.
- Integral charge pump option allows the pump to run at higher speed and achieve good cold start performance.
- Full through-drive capability is suitable for adding axial piston pumps and gear pumps.
- Optimized cradle bearing improves pump service life.
- PLUS+1® compliant controls.
- Can be used together in combination with other Danfoss Power Solutions products in the overall hydraulic system, such as:
  - Pumps (S45, S90, H1P, gear pumps, etc.)
  - PVG valves
  - Motors (S90, H1B, etc.)

### D1P typical applications

- Concrete Machinery
- Mining Machinery
- Drilling Machinery
- Material Handling
- Marine and Off-shore Machinery
- Oil Machinery

**General Information**

- Excavators
- Wheel Loaders
- Industrial Hydraulics

**Design**

**D1P sectional view**

The cross sectional view of the D1P can be used to identify individual parts of the product.

*Series D1 pump (w/charge pump) cross-section view*

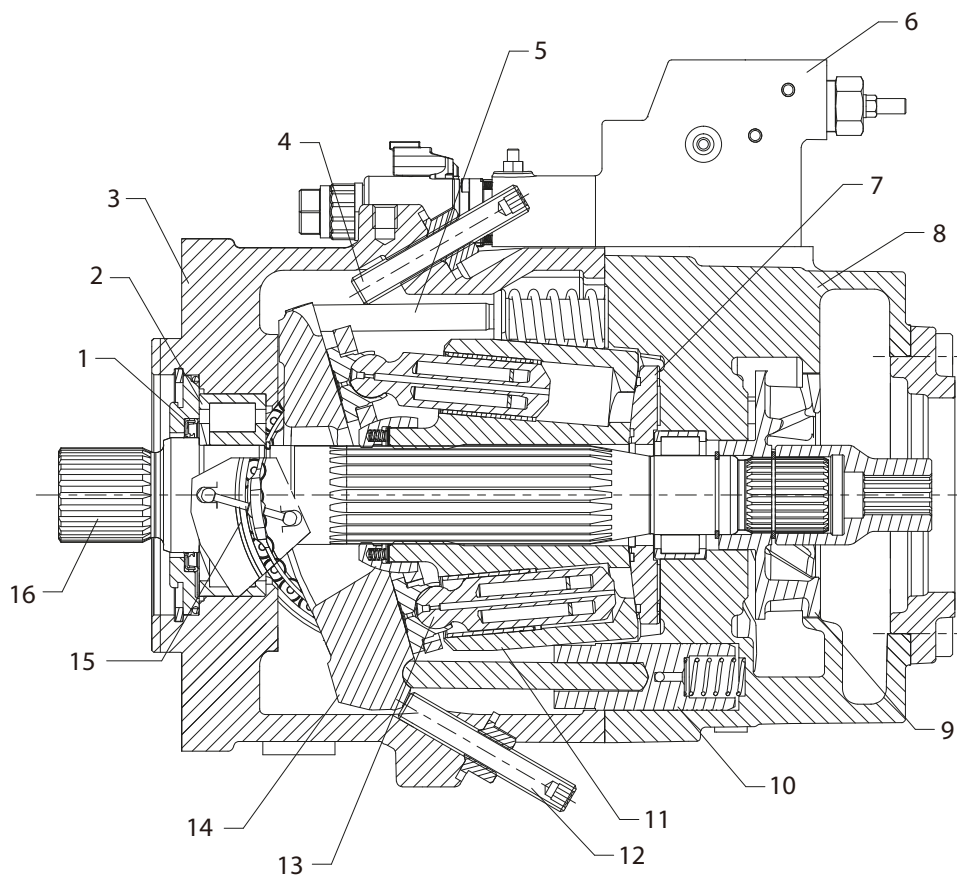

- |  |                           |   |
|--|---------------------------|---|
| <b>1.</b> Shaft Seal                   | <b>2.</b> Roller Bearing  | <b>3.</b> Housing                       |
| <b>4.</b> Minimum Displacement Limiter | <b>5.</b> Bias Piston     | <b>6.</b> Control (TPE5/TPE2)           |
| <b>7.</b> Valve Plate                  | <b>8.</b> End cap         | <b>9.</b> Charge Pump                   |
| <b>10.</b> Servo Piston                | <b>11.</b> Cylinder Block | <b>12.</b> Maximum Displacement Limiter |
| <b>13.</b> Piston                      | <b>14.</b> Swashplate     | <b>15.</b> Swashplate Bearing           |
| <b>16.</b> Input Shaft                 |                           |   |

Some internal parts may be different depending on frame size and options desired.

**General Information**

**D1P schematic with charge pump**

*Basic schematic without control/with charge pump*

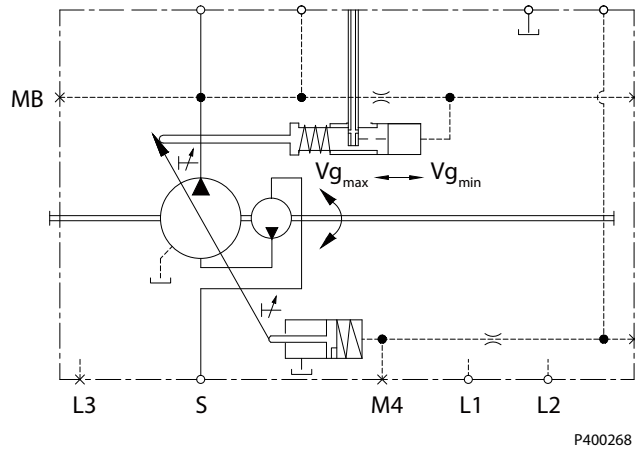

P400268

The charge pump (see schematic) is a circulating pump with which the pump is charged and therefore can be operated at higher speeds. This also improves cold starting at low temperatures and high viscosity of the hydraulic fluid. The pressurized reservoir is therefore unnecessary in most cases. A reservoir pressure of a max. 2 bar is permissible with charge pump.



**Technical Specifications**
**D1 130-260 pump specifications**
*(Theoretical values, without efficiency and tolerances; value rounded)*

Features		Unit	130		145		193		260
			W/O Impeller	W/ Impeller	W/O Impeller	W/ Impeller	W/O Impeller	W/ Impeller	W/ Impeller
Displacement	Maximum	cm <sup>3</sup> [in <sup>3</sup> ]	130 [7.93]	130 [7.93]	145 [8.85]	145 [8.85]	193 [11.78]	193 [11.78]	260 [15.87]
	Minimum		0	0	0	0	0	0	0
Available rotation		CCW [L]	●	●	●	●		●	●
		CW [R]	●	●	●	●	●	●	●
Input speed	Min.	rpm	500	500	500	500	500	500	500
	Rated at max. displacement (Vg max.)		2200 <sup>1</sup>	2500 <sup>2</sup>	2200 <sup>1</sup>	2500 <sup>2</sup>	2200 <sup>1</sup>	2500 <sup>1</sup>	2300 <sup>2</sup>
	Maximum at Vg < Vg max. <sup>3</sup>		2500	2500	2200	2500	2500	2500	2300
Flow at max. speed & displacement (n max. & Vg max.)		l/min [US gal/min]	286 [76]	325 [86]	319 [84]	363 [96]	425 [112]	483 [128]	598 [158]
System (working) pressure <sup>4</sup>	Max. working pressure	bar [psi]	350 [5076]						
	Max. pressure		400 [5802]						
Inlet pressure (absolute)	Minimum	bar [psi]	0.8 [11.6]	0.6 [8.7]	0.8 [11.6]	0.6 [8.7]	0.8 [11.6]	0.6 [8.7]	0.6 [8.7]
	Maximum		30 [435] <sup>5</sup>	2 [29]	30 [435]	2 [29]	30 [435]	2 [29]	2 [29]
Case pressure (absolute)	Maximum above inlet	bar [psi]	1.2 [17.4]						
	Maximum		2 [29]						
Filling capacity		L [US gal]	2.9 [0.77]		2.9 [0.77]		3.8 [1]		4.6 [1.3]
Torque at Vg max. & Δp = 350 bar		N·m [lbf·in]	724 [6408]		808 [7151]		1075 [9515]		1448 [12816]
Power at Q max. (max. flow) & Δp = 350 bar		kW [hp]	159 [213]	190 [255]	186 [249]	211 [283]	248 [332]	281 [377]	349 [468]
Mass moment of inertia of internal rotating components		kg·m <sup>2</sup> [slug·ft <sup>2</sup> ]	0.0299 [0.0221]	0.0306 [0.0226]	0.0299 [0.0221]	0.0306 [0.0226]	0.0547 [0.0403]	0.0576 [0.0426]	0.2080 [0.1537]
Mass		kg [lb]	68 [150]	74 [163]	68 [150]	74 [163]	101 [222]	106 [234]	141 [311]
External shaft loads	External moment M <sub>e</sub>	N·m [lbf·in]	476 [4213]		476 [4213]		822 [7275]		1081 [9568]
Mounting flange load moments	Vibratory (continuous)	N·m [lbf·in]	4553 [40297]		4553 [40297]		6286 [55636]		8477 [75027]
	Shock (maximum)		8692 [76930]		8692 [76930]		13782 [121980]		16338 [144603]

<sup>1</sup> The values apply at absolute pressure (Pabs) of at least 0.8 bar [11.6psi] at the suction port S and mineral hydraulic fluid.

<sup>2</sup> The values apply at absolute pressure (Pabs) of at least 0.6 bar [8.7psi] at the suction port S and mineral hydraulic fluid.

<sup>3</sup> The values apply at Vg ≤ Vg max or in case of an increase in the inlet pressure (Pabs) at the suction port S. Please refer to *Inlet Pressure vs Speed Graph* at [D1P speed overview](#) on page 22

<sup>4</sup> Applied pressures above maximum working pressure requires Danfoss application approval. Maximum (peak) pressure is the highest intermittent (t<1s) outlet pressure allowed.

<sup>5</sup> If the application requires the higher inlet pressure than 5 bar [72.5psi] (up to 30 bar [435psi]), please contact.Danfoss Power Solutions.

[Counterclockwise \(CCW\) & Clockwise \(CW\) directions as viewed from the shaft end of the pump.](#)

Exceeding the permissible values could cause a loss of function, reduced life or the destruction of the pump.

Do not exceed the values shown in the table above.

**Technical Specifications**
**D1P fluid specifications**

Features		Units	Value
Viscosity	Intermittent <sup>1)</sup>	mm <sup>2</sup> /sec [SUS]	5 [42]
	Minimum		7 [49]
	Recommended range		16 - 36 [81 - 168]
	Maximum (cold start) <sup>2)</sup>		1600 [xxxxx]
Temperature range	Minimum (cold start) <sup>2)</sup>	°C [°F]	-40 [-40 °F]
	Maximum intermittent <sup>1)</sup>		115 [239 °F] <sup>3)</sup>
Filtration (minimum) Cleanliness per ISO 4406	Temperature Range: -40 - 90 °C [-40 - 194°F]		20/18/15
	Temperature Range: 90 - 115 °C [194 - 239°F]		19/17/14

<sup>1)</sup> Intermittent = Short term  $t < 3\text{min}$  per incident.

<sup>2)</sup> Cold start = Short term  $t < 3\text{min}$ ,  $p \leq 30\text{ bar}$  [435 psi],  $n \leq 1000\text{ min}^{-1}$ (rpm) , please contact Danfoss Power Solutions especially when the temperature is below  $-25\text{ °C}$  [-13 °F].

<sup>3)</sup> Must not be exceeded locally either (e.g. in the bearing area) . The temperature in the bearing area is (depending on pressure and speed ) up to  $5\text{ °C}$  [41 °F] higher than the average case drain temperature.

**Technical Specifications**

**D1P 260 angle sensor**

**Angle sensor principle**

The angle sensor option is exclusive to the D1P 260.

The angle sensor option offered in D1P allows users to measure the angle of pump displacement. The angle sensor is an electronic sensor mounted to the housing of the pump, which reads the pump stroke angle based on the swashplate position. Interfacing with the angle sensor is achieved through a 4-pin DEUTSCH DTM04-4P receptacle attached to a flexible connection cable (for a mating connector, use DEUTSCH plug DTM06-4S). The sensor is mounted to the pump within an aluminum housing to prevent magnetic interference.

**Location**

When the input shaft with the control is on the top side, the angle sensor will be viewed on the right-hand side. This convention is true for both clockwise and counterclockwise rotation.

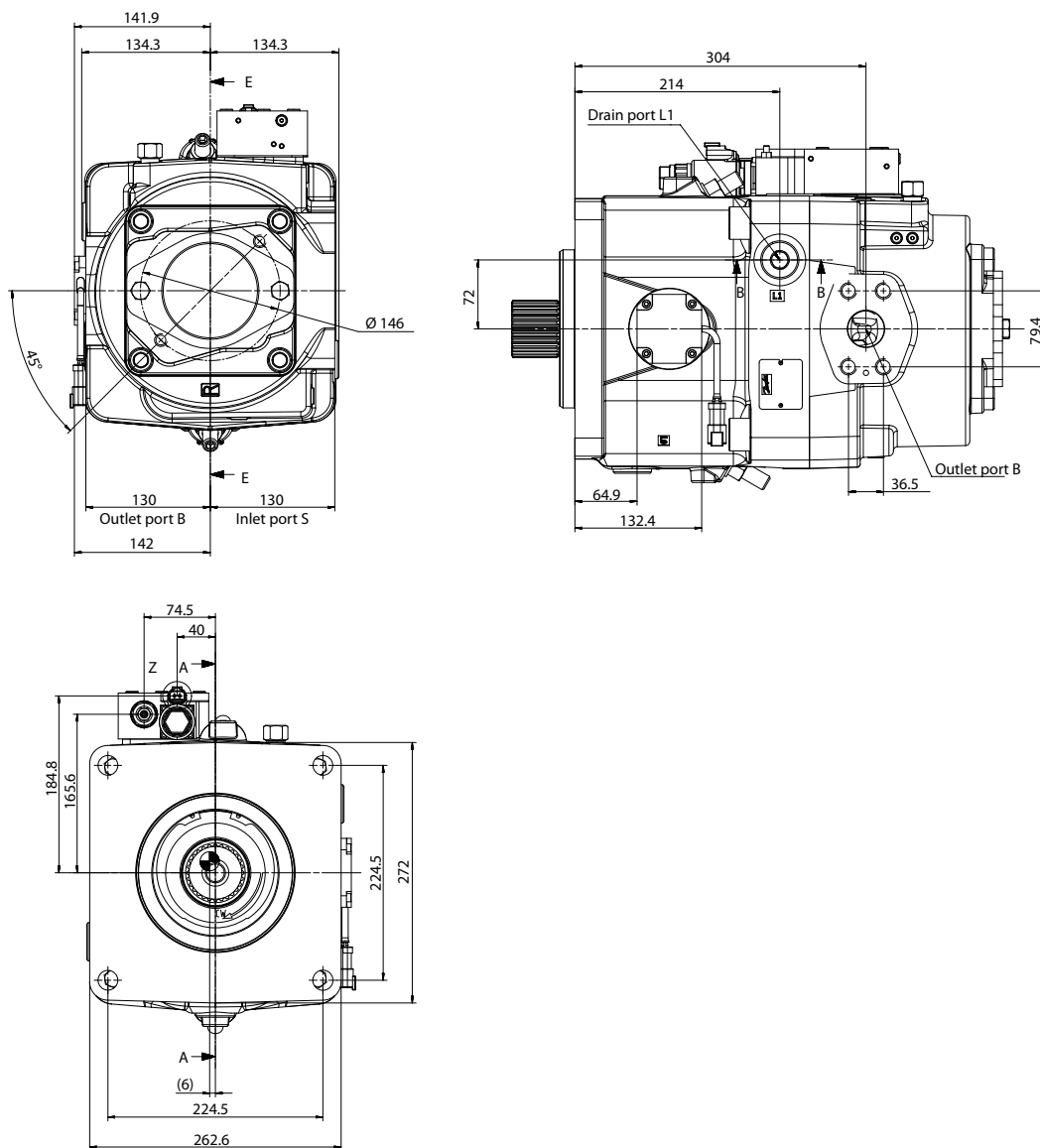

**Technical Specifications**

**Angle sensor characteristics**

The angle sensor package incorporates two sensor signals (primary & secondary) within a single sensor housing. This package allows for improved accuracy and troubleshooting.

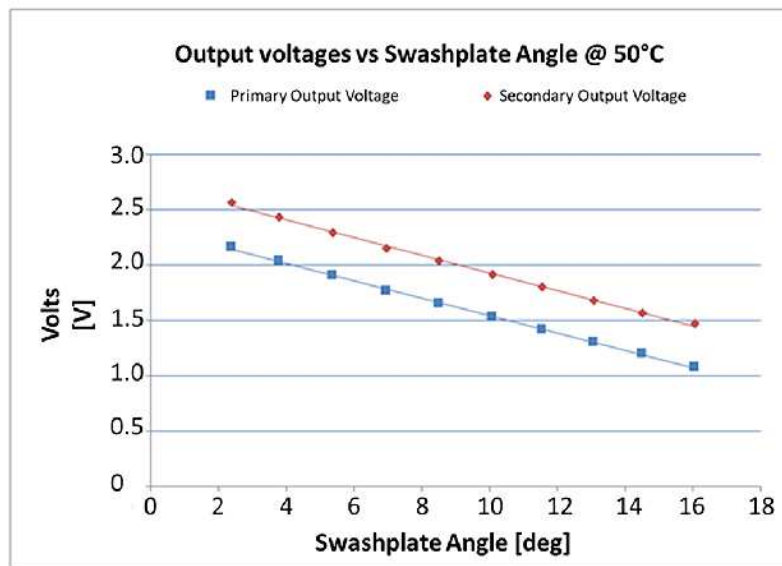
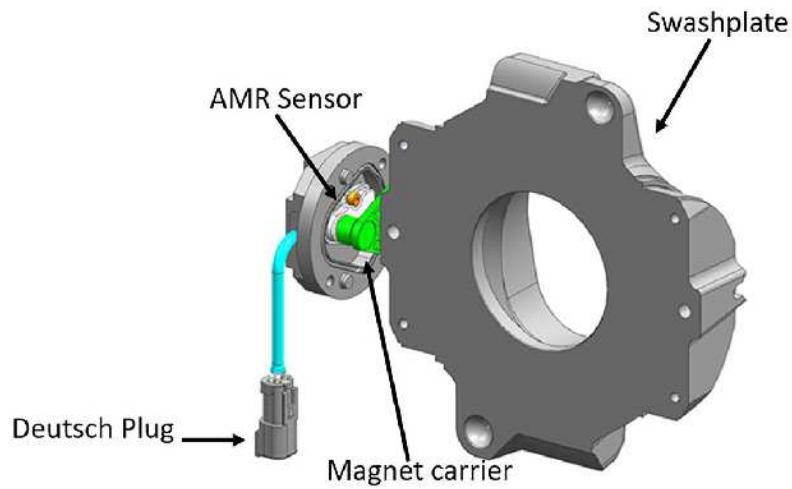

**Technical Specifications**
**Angle sensor electrical specifications**

Description	Minimum	Typical	Maximum	Unit	Note
Supply (V+)	4.75	5	5.25	Vdc	Sensor is ratiometric in the voltage range
Supply protection	-	-	28	Vdc	Sensor will switch off above 5.5 V
Supply current drawn	-	22	25	mA	Sensor supply at 5 V
Output short circuit current (VDD to SIG ½ and GND to SIG ½)	-	-	7.5	mA	Additional 7.5 mA for each sensor signal, total sensor 7.5x2+22=37 mA typical for FSO
Resolution	-	0.03	-	Degree	11 bit output channel
Hysteresis	-	-	-	-	Design of sensor eliminates any mechanical hysteresis
Environment temperature range	-40 [-40]	80 [176]	104 [220]	°C [°F]	If temperature limits are exceeded, the sensor will function at a reduced level of performance
Operating temperature range	20 [68]	50 [122]	104 [220]	°C [°F]	Temperature of oil
Storage temperature	-40 [-40]	-	125 [257]	°C [°F]	-
Refresh rate of the sensor	-	-	100	µs	Internal ADC refresh rate

**Angle sensor calibration**

A 2-point calibration of the sensor is recommended, with points measured at pump standby and maximum pump stroke. Maximum pump stroke can be achieved when the pump input shaft is not being turned, as D1P pumps are biased to maximum displacement. In some cases, the pump may need to be turned momentarily to ensure the pump is in the maximum displacement position; this can be achieved through a momentary switching of the engine starter on/off.

For minimum displacement calibration, the angle sensor can be calibrated by sending the pump to a standby condition, either high-pressure with a pressure compensator (PC control) or low-pressure with a flow compensator (LS control). Low-pressure standby is recommended if the control has load sensing or remote PC functionality. For best results, it is recommended to rotate the prime mover at the highest operating speed to achieve the lowest angle possible at standby conditions.

**Technical Specifications****Angle sensor functionality**

The D1P angle sensor option is intended for advanced functionality such as electronic torque limiting, duty cycle measurement, troubleshooting, etc. The angle sensor is PLUS+1<sup>®</sup> compliant with an available hardware compliance block.

## Angle Sensor Intended Functionality:

- Electronic Torque Limiting\*
- Duty Cycle Recording
- Troubleshooting

## Angle Sensor Unsupported Functionality:

- Displacement/Flow Control

---

\* Pre-programmed Electronic Torque Limiting control packages are currently not offered for D1P.

**Model Code**

**D1P model code**

The below illustration and the following sections describe how to identify parts of the model code and availability of certain part options based on frame size.

Example model code; D1P 260 shown

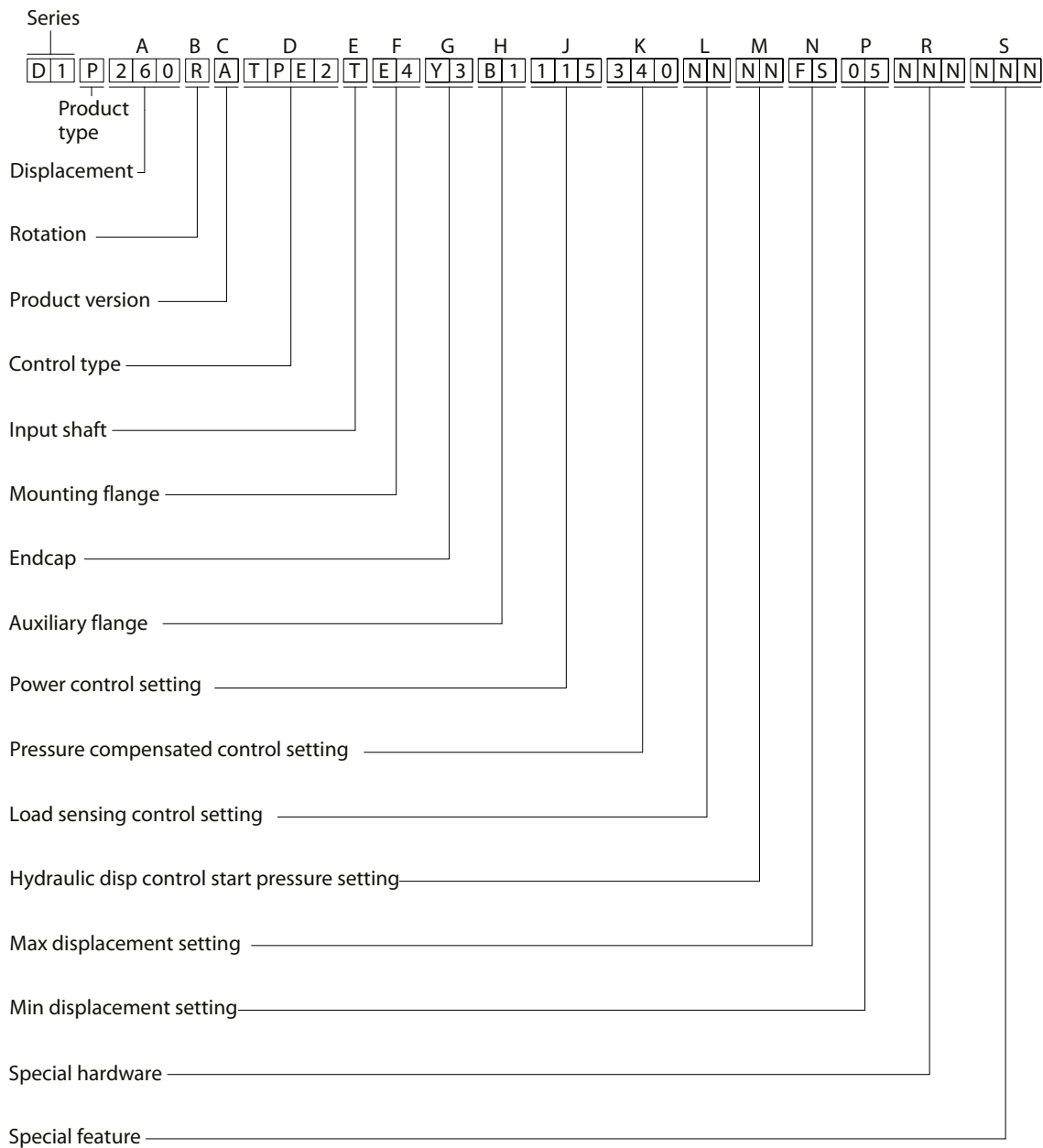

**Model Code**
**D1P 130-260 displacement, rotation and product version**
*Displacement*

Code	Description	130	145	193	260
130	130 cm <sup>3</sup> [7.93 in <sup>3</sup> ] max. displacement per revolution	●			
145	145 cm <sup>3</sup> [8.85 in <sup>3</sup> ] max. displacement per revolution		●		
193	193 cm <sup>3</sup> [11.78 in <sup>3</sup> ] max. displacement per revolution			●	
260	260 cm <sup>3</sup> [15.87 in <sup>3</sup> ] max. displacement per revolution				●

*Rotation*

Code	Description	130	145	193	260
R	Clockwise [CW]	●	●	●	●
L	Counter Clockwise [CCW]	●	●	●	●

*Product Version*

Code	Description	130	145	193	260
A		●	●	●	●

**D1P 130-260 control types**

Code	Description	130	145	193	260
NPNN	Pressure Compensated Control	●	●	●	●
NPSN	Pressure Compensated Control + Load Sensing Control	●	●	●	●
NPNR	Pressure Compensated Control + Remote Pressure Compensated Control	●	●	●	●
TPSN	Power Control + Pressure Compensated Control + Load Sensing Control	●	●	●	●
NNES	Positive Electric Displacement Control (24V DEUTSCH, 2-pin) w/Manual Override + Load Sensing Control	●	●	●	●
TPE2	Power Control + Pressure Compensated Control + Positive Electric Displacement Control (24V DEUTSCH, 2-pin) w/Manual Override			●	●
TPE5	Power Control + Pressure Compensated Control + Positive Electric Displacement Control (24V DEUTSCH, 2-pin) w/Manual Override (The control outline and size is the same as the 193/260 TPE2 control)	●	●		
NPE2	Pressure Compensated Control + Positive Electric Displacement Control (24V DEUTSCH, 2-pin) w/Manual Override	●	●	●	●
NPE0	Pressure Compensated Control + Positive Electric Displacement Control (24V DEUTSCH, 2-pin) w/Manual Override w/o Shuttle valve	●	●	●	●

*Control Code Explanation:*

- First digit: Power control (Torque control) , "N" means no power control.
- Second digit: Pressure compensated control, "N" means no pressure compensated control.
- Third & Fourth digits: Proportional displacement control or Load sensing control , "NN" means no control in either category.

 **Warning**

A relief valve is required to be installed in the pump outlet for additional system protection. Failure to install the relief valve can lead to system damage and/or injury.



**Model Code**
**D1P 130-260 input shaft options**

Code	Description	130	145	193	260
T	130/145/193: Spline, DIN 5480 W50 x 2 x 30 x 24 x 9g; 260: Spline, DIN 5480 W60 x 2 x 30 x 28 x 9g; Shaft Seal Material: FKM	●	●	●	●
S	Spline, SAE J744 1 3/4in, 13T 8/16 DP; Shaft Seal Material: FKM	●	●	●	●
A	193: Spline, SAE J744 2in, 15T 8/16 DP; 260: Spline, SAE J744 2 1/4in, 17T 8/16 DP; Shaft Seal Material: FKM			●	●
P	Straight Keyed DIN 6885, 130/145: AS14 x 9 x 80 193: AS16 x 10 x 100 260: AS18 x 11 x 100 Shaft Seal Material: FKM	●	●	●	●
K*	SAE J744 (D/E) 3in straight keyed shaft 0.4375x3.000in			●	●

\* There is no impeller option for sizes 130 and 145 with this shaft.

**D1P 130-260 mounting flange options**

Code	Description	130	145	193	260
D4	SAE J744 152-4 (D)	●	●		
E4	SAE J744 165-4 (E)			●	●

**D1P 130-260 end cap and main port options**
*End cap and main ports*

Code	Description	Rotation	130	145	193	260
N1	Radial, side, flange ports Inlet: 3in port, M16 x 2; Outlet: 1in port, M12 x 1.75 SAE J518 without impeller	CW [R] CCW [L]	●	●		
N2	Radial, side, flange ports Inlet: 3 1/2in, M16 x 12; Outlet: 1 1/2in, M16 x 2 SAE J518 Without impeller	CW [R]			●	
Y1	Radial, side, flange ports Inlet: 3in port, M16 x 2; Outlet: 1 1/4in port, M14 x 2 SAE J518 With impeller	CW [R] CCW [L]	●	●		
Y2	Radial, side, flange ports Inlet: 3 1/2in port, M16 x 2; Outlet: 1 1/2in port, M16 x 2 SAE J518 With impeller	CW [R] CCW [L]			●	
Y3	Radial, side, flange ports Inlet: 4in port, M16 x 2; Outlet: 1 1/2in port, M16 x 2 SAE J518 With impeller	CW [R] CCW [L]				●

**Model Code**
**D1P 130-260 auxiliary mounting flange options**
*Auxiliary mounting flange (through-drive flange)*

Code	Description	130	145	193	260
NN	No auxiliary flange	●	●	●	●
A1	SAE J744 82-2 (A); Spline coupling: 5/8in 9T 16/32DP	●	●	●	●
A2	SAE J744 82-2 (A); Spline coupling: 3/4in 11T 16/32DP	●	●		
A3	SAE J744 82-2 (A); Spline coupling: 7/8in 13T 16/32DP			●	●
B1	SAE J744 101-2 (B) ; Spline coupling: 7/8in 13T 16/32DP	●	●	●	●
B2	SAE J744 101-2 (B); Spline coupling: 1in 15T 16/32DP	●	●	●	●
BA	SAE J744 101-2 (B); Spline coupling: 7/8in 13T 16/32DP; Adapter 90°	●	●	●	●
BB	SAE J744 101-2 (B); Spline coupling: 7/8in 13T 16/32DP; Cover 45°			●	●
C5	SAE J744 127-2&4 (C) ; Spline coupling:1 1/4in 14T 12/24DP	●	●	●	●
C9	SAE J744 127-2&4 (C); Spline coupling: 1 3/4in 13T 8/16DP			●	●
D2	SAE J744 152-4 (D); Spline coupling: 1 3/4in 13T 8/16DP	●	●	●	●
D5	SAE J744 152-4 (D) ; Spline coupling: N50x2x30x24x9H	●	●	●	●
E2	SAE J744 165-4 (E) ; Spline coupling: N50 x 2 x 30 x 24 x 9H			●	●
E3	SAE J744 165-4 (E) ; Spline coupling: N60 x 2 x 30 x 28 x 9H				●

**D1P 130-260 power control settings**
*Power control setting at 1500rpm (kW), "3 digit code"*

Code <sup>1</sup>	Description	130	145	193	260
NNN	No Power Control	●	●	●	●
XXX	xxx kW between ranges specified below (For example: Code "090" means 90kW) at 1500 rpm				
030-115	30-115 kW [40-154 hp] at 1500 rpm <sup>2</sup>	●	●		
035-155	35-155 kW [47-208 hp] at 1500 rpm <sup>2</sup>			●	
040-210	40-210 kW [54-282 hp] at 1500 rpm <sup>2</sup>				●

<sup>1</sup> For settings out of these ranges, please contact Danfoss Power Solutions.

<sup>2</sup> Only increments of 5kW [6.7 hp] are allowed. E.g. 035, 040, 045, etc.)

If the speed is not 1500rpm, please make a conversion using the following formula, assuming constant torque:

$$P_{\text{setting@1500 rpm}} = P_{\text{actual}} * \frac{1500}{n_{\text{actual}}}$$

For example:

If actual power is 110 kW at 2100 rpm, the conversion to obtain the power control setting at 1500 rpm should be  $110 * 1500 / 2100 = 79$ , choose 080 option (round to closest 5 kW increment option).

**Model Code**
**D1P 130-260 pressure compensated control setting**

*Pressure compensated control setting (bar), "3 digit code"*

Code*	Description	130	145	193	260
NNN	No Pressure compensated control	●	●	●	●
XXX	xxx bar between the range specified below (For example: Code "320" means 320 bar [4641 psi])				
150~350	150~350 bar [2176~5076 psi] (Please select pressure compensated control setting in increments of 10 bar [145 psi]. E.g. 150 or 160 or 170, etc.)	●	●	●	●

\* For settings out of these ranges, please contact Danfoss Power Solutions.

**D1P 130-260 load sensing control settings**

*L - Load Sensing Control Setting (bar), "2 digit code"*

Code	Description	130	145	193	260
NN	No load sensing control	●	●	●	●
XX	xx bar between the range specified below (For example: Code "25" means 25 bar [363 psi])				
10~35*	10~35 bar [145~508 psi] (Please select load sensing control setting in increments of 1 bar [14.5 psi]. E.g. 10 or 11 or 12, etc.)	●	●	●	●

\* For settings out of these ranges, please contact Danfoss Power Solutions. Range allowed for NPNR (Pressure compensated + Remote Pressure compensated control) is 15-35 bar

**D1P 130-260 hydraulic displacement control setting**

*Hydraulic displacement control start pressure setting, "2 digit code"*

Code	Description	130	145	193	260
NN	No hydraulic displacement control	●	●	●	●
04-10	4-10 bar			●	●

**D1P 130-260 maximum displacement settings**

*Maximum displacement setting, "2 digit code"*

Code	Description	130	145	193	260
FS	Factory setting : 100%	●	●	●	●
XX <sup>1</sup>	XX% of maximum displacement (For example: Code "90" means 90% of maximum displacement) <sup>2</sup>	●	●	●	●

<sup>1</sup> Please consider frame sizing and increments when selecting a maximum displacement setting (see [displacement limiter](#) for more information).

<sup>2</sup> Only increments of 5% are allowed. (E.g. 70, 75, 80 etc.)

**D1P 130-260 minimum displacement settings**

*Minimum displacement setting, "2 digit code"*

Code	Description	130	145	193	260
FS	0% of maximum displacement limit setting	●	●	●	●
XX	XX% of maximum displacement limit setting <sup>1</sup>	●	●	●	●

<sup>1</sup> Only increments of 5% are allowed. (E.g. 05, 10, etc.)

**Model Code**

[If a different minimum displacement setting is required, please contact Danfoss Power Solutions.](#)

**D1P 130-260 special hardware and special features**

*Special hardware*

Code	Description	130	145	193	260
NNN	None	●	●	●	●
NNA	No special hardware; with angle sensor				●

*Special features*

Code	Description	130	145	193	260
NNN	Factory Setting (Paint-black, tag, Danfoss, format A)	●	●	●	●
NXN	Factory Setting (No paint, tag, Danfoss, format A, w/o filter)	●	●	●	●
NNF	Factory Setting (Paint-black, tag, Danfoss, format A) with control oil filter				●

**Model Code**

**D1P tandem pump information**

Information about tandem pump direction and ordering instructions are found below.

**Pump direction**

Auxiliary pump  
INDEX = 0°

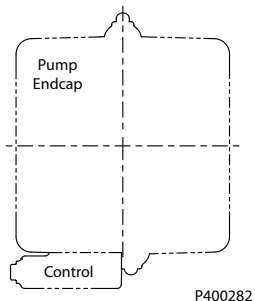

Auxiliary pump  
INDEX = 90°

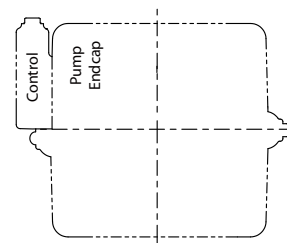

When assembling a system the first pump is always to be considered at 0° INDEX as shown below.

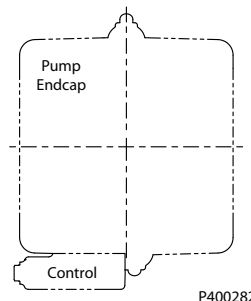

Auxiliary pump  
INDEX = 270°

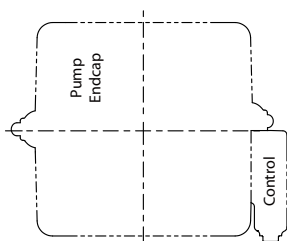

Auxiliary pump  
INDEX = 180°

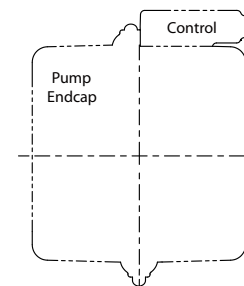

For gear pump tandem angle information, please contact Danfoss Power Solutions.

**Ordering tandem pumps**

When ordering tandem pumps, the type designations of the 1st and 2nd pumps must be connected by a "+", and tandem pump angle should be given as indicated below.

*Ordering example:*

D1P193RATPE2TE4Y2E2090320NNNNFSSFNNNNNNN +

D1P193RATPE2TE4Y2NN090320NNNNFSSFNNNNNNN

Tandem angle 0° + 180°

**Parameters**
**D1P pressure overview**

<b>Maximum working pressure</b>	The highest recommended outlet (application). Operating at or below this pressure should yield satisfactory product life. For all applications, the load should move below this pressure. This corresponds to the maximum allowable pressure compensated control setting.
<b>Maximum (peak) pressure</b>	The highest intermittent ( $t < 1s$ ) outlet pressure allowed. Maximum machine load should never exceed this pressure, and pressure overshoots should not exceed this pressure.
<b>Inlet pressure</b>	The absolute pressure in the pump suction port, it is related to pump speed. Make sure it is in the allowable range, see <a href="#">D1 pump specifications</a> .
<b>Case pressure</b>	The case pressure at the ports L1 and L2 may be a maximum of 1.2 bar [17.4 psi] higher than the inlet pressure at the port S but not higher than 2 bar. Size drain plumbing accordingly and connect it to tank directly. The housing must always be filled with hydraulic fluid.

**D1P speed overview**

<b>Rated speed</b>	The fastest recommended operating speed at full displacement and at least 0.6 bar [8.7 psi] abs with charge pump (0.8 bar [11.6 psi] abs without charge pump) inlet pressure. Operating at or below this speed should yield satisfactory product life.
<b>Maximum speed</b>	The highest recommended operating speed at full power conditions. Operating at or beyond maximum speed requires positive inlet pressure and/or a reduction of pump outlet flow. Refer to the <i>Inlet pressure vs. speed</i> chart below.

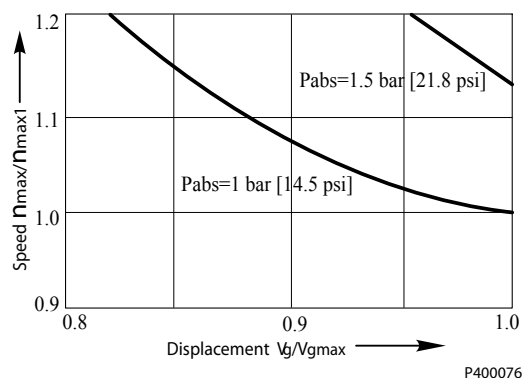
*Inlet pressure vs. speed*

<b>Minimum speed</b>	The lowest operating speed allowed. Operating below this speed will not yield satisfactory performance.
----------------------	---

**Caution! Threat to pump life!**

Working outside of the pump's operating parameters may result in shortened life expectancy of the pump.

Always work within the operating conditions of the pump application.

With accurate duty cycle information, your Danfoss Power Solutions representative can assist you in calculating expected pump life.

**Parameters**

**Performance**

**D1P input power**

Input power requirements depend on displacement per revolution, speed, efficiency, and operating pressure.

*130cc power vs input speed*

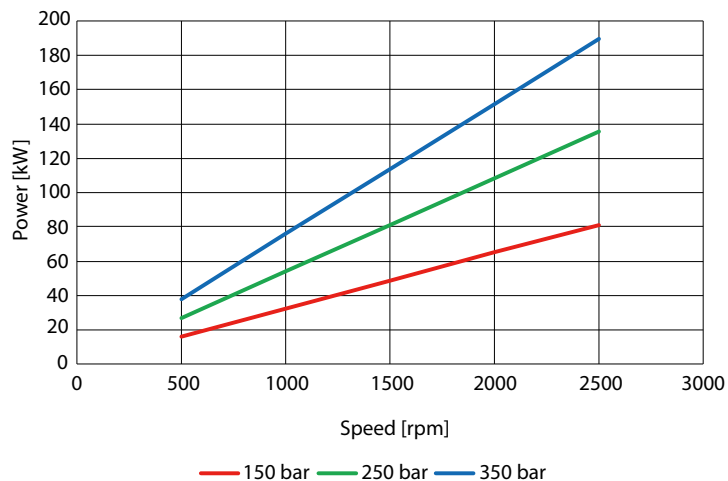

*145cc power vs input speed*

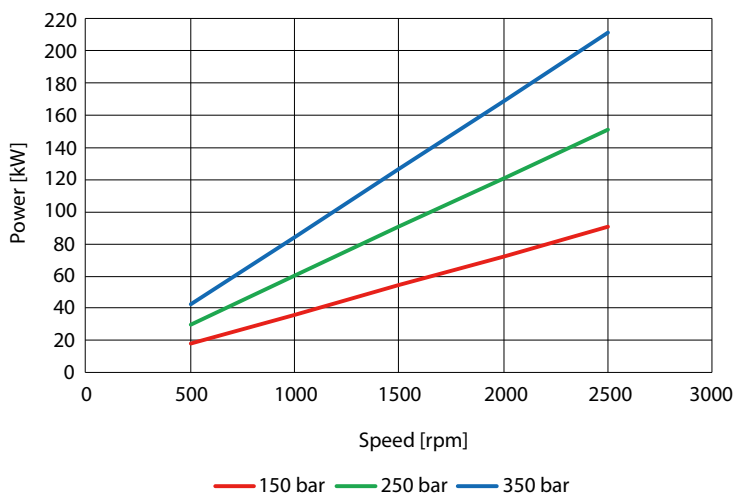

**Parameters**

*193cc power vs input speed*

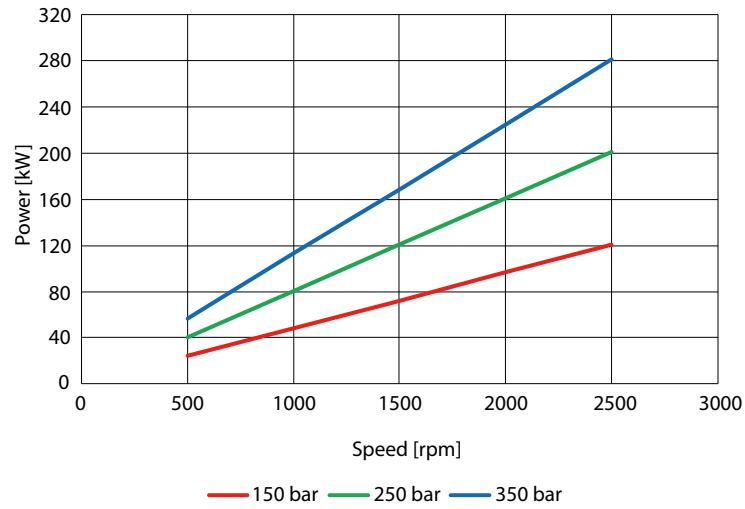

*260cc power vs input speed*

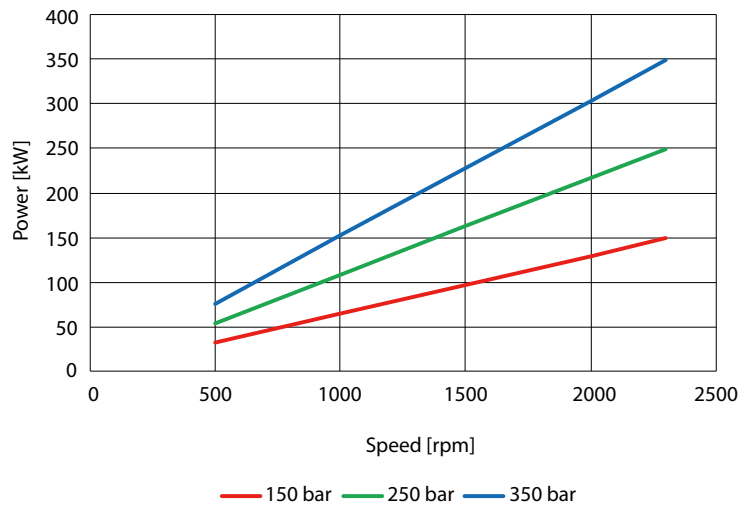



**Parameters**

**D1P output flow**

Output flow depends on displacement per revolution, speed, and efficiency.

*130cc flow vs speed*

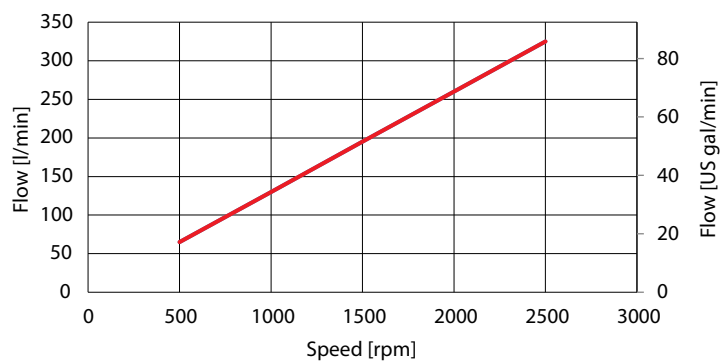

*145cc flow vs speed*

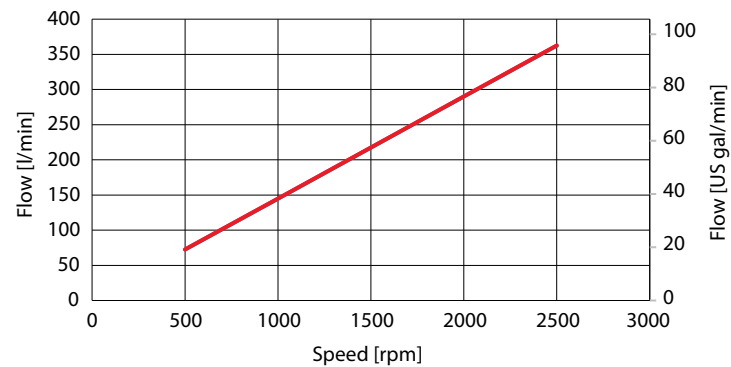

**Parameters**

*193cc flow vs speed*

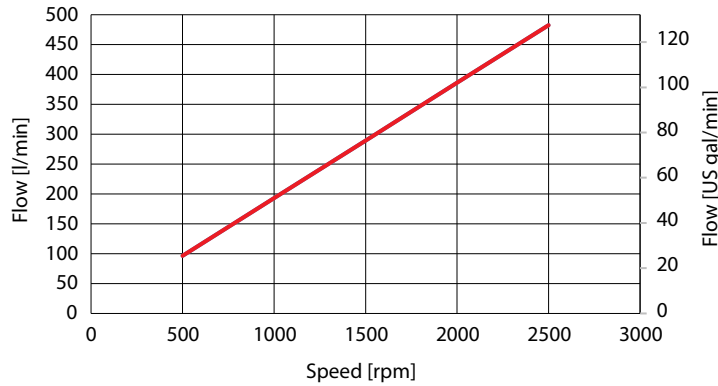

*260cc flow vs speed*

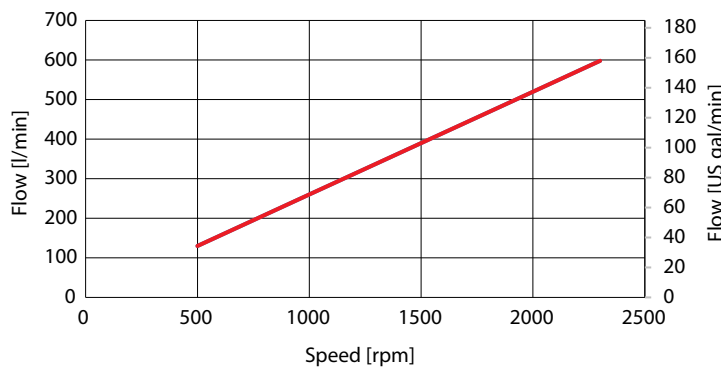

**D1P efficiency overview**

Efficiency data depends on various operating parameters such as: working and inlet pressure, operating temperature, displacement, and fluid viscosity. For an accurate efficiency calculation, please contact your Danfoss Power Solutions representative.

All performance data are theoretical values, without efficiency or tolerances. Data valid at full displacement and operation parameters within the recommended ranges.

## Parameters

### D1P fluid overview

Ratings and performance data for D1 pumps are based on operating with premium hydraulic fluids containing oxidation, rust, and foam inhibitors. These include premium turbine oils, API CD engine oils per SAE J183, M2C33F or G automatic transmission fluids (ATF), Dexron II (ATF) meeting Allison C-3 or Caterpillar T0-2 requirements, and certain specialty agricultural tractor fluids. For more information on hydraulic fluid selection, see Danfoss Power Solutions publications **BC152886484524** *Hydraulic Fluids and Lubricants*, Technical Information, and **520L0465** *Experience with Biodegradable Hydraulic Fluids*, Technical Information.

### D1P viscosity

**Minimum Viscosity** This should only occur during brief occasions of maximum ambient temperature and severe duty cycle operation.

**Maximum Viscosity** This should only occur at cold start. Pump performance will be reduced. Limit speeds until the system warms up.

Maintain fluid viscosity within the recommended range for maximum efficiency and pump life.

### D1P temperature overview

**Minimum Temperature** Relates to the physical properties of the component materials. Cold oil will not affect the durability of the pump components. However, it may affect the ability of the pump to provide flow and transmit power

**Maximum Temperature** Relates to material properties. Don't exceed it. Measure maximum temperature at the hottest point in the system. This is usually the case drain.

### D1P fluid velocity

Choose piping sizes and configurations sufficient to maintain optimum fluid velocity, and minimize pressure drops. This reduces noise, pressure drops, overheating and maximizes system life and performance.

#### *Recommended fluid velocities*

<b>System lines</b>	6 to 9 m/sec
<b>Suction line</b>	1 to 2 m/sec
<b>Case drain</b>	3 to 5 m/sec

Typical guidelines; obey all pressure ratings.

### Velocity equations

#### **SI units**

Q = flow (l/min)

A = area (mm<sup>2</sup>)

Velocity = (16.67·Q)/A (m/sec)

## Parameters

### D1P shaft torque ratings

Shaft drawings and maximum torque ratings are found in these sections:

- [Size 130/145 shaft specifications](#)
- [Size 193 shaft specifications](#)
- [Size 260 shaft specifications](#)

Maximum torque ratings are based on shaft strength with no radial force; do not exceed the torque limits.

### D1P shaft load

Series D1 pump bearing is capable of accepting external radial and thrust (axial) loads. The external radial shaft load limits are a function of the load position, orientation, and the operating conditions of the pump.

The maximum allowable radial load ( $R_e$ ) is based on the maximum external moment ( $M_e$ ) and the distance ( $L$ ) from the mounting flange to the load. Compute radial loads using the formula below. [D1 pump specifications](#) gives maximum external radial load ( $R_e$ ) and thrust (axial) load ( $T_{in}$ ,  $T_{out}$ ) limits.

$$M_e = R_e \cdot L$$

$L$  = Distance from mounting flange to point of load

$M_e$  = Maximum external moment

$R_e$  = Maximum radial side load

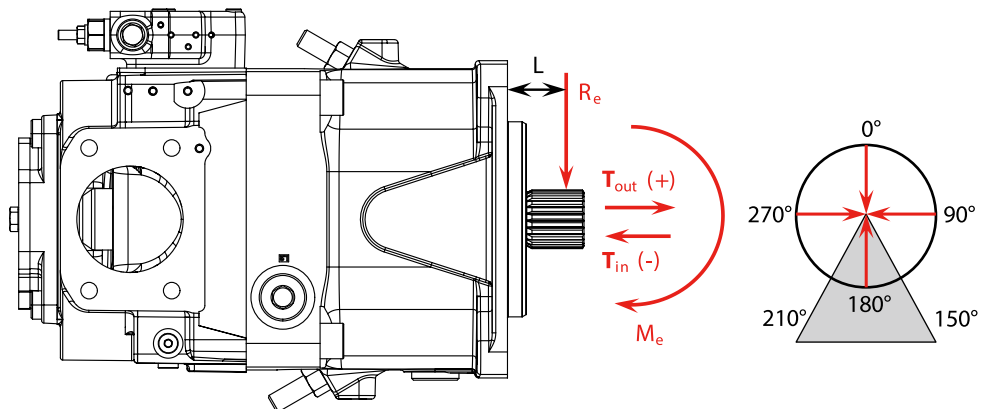

P400077

All shaft loads affect bearing life. In applications where external shaft loads cannot be avoided, maximize bearing life by orienting the load between the 150° and 210° positions, as shown.

### D1P mounting flange loads

Adding auxiliary pumps and/or subjecting pumps to high shock loads may overload the pump mounting flange. [D1 pump specifications](#) gives allowable continuous and shock load moments. Applications with loads outside allowable limits require additional pump support.

- **Shock load moment ( $M_S$ )** is the result of an instantaneous jolt to the system.
- **Continuous load moments ( $M_C$ )** are generated by the typical vibratory movement of the application.

### D1P auxiliary mounting pads

Auxiliary mounting pads are available. Since the auxiliary pad operates under case pressure, use an O-ring to seal the auxiliary pump mounting flange to the pad. Oil from the main pump case lubricates the drive coupling.

**Parameters**

- The combination of auxiliary shaft torque and main pump torque must not exceed the maximum pump input shaft rating. Shaft drawing section in Installation drawings chapter gives input shaft torque ratings.
- Applications subject to severe vibratory or shock loading may require additional support to prevent mounting flange damage. The table gives allowable continuous and shock load moments.

**D1P estimating overhung load moments**

Use the equations below to estimate the overhung load moments for multiple pump mounting. See Installation drawings chapter to find the distance from the mounting flange to the center of gravity. Refer to the to find pump weight.

*Overhung load example*

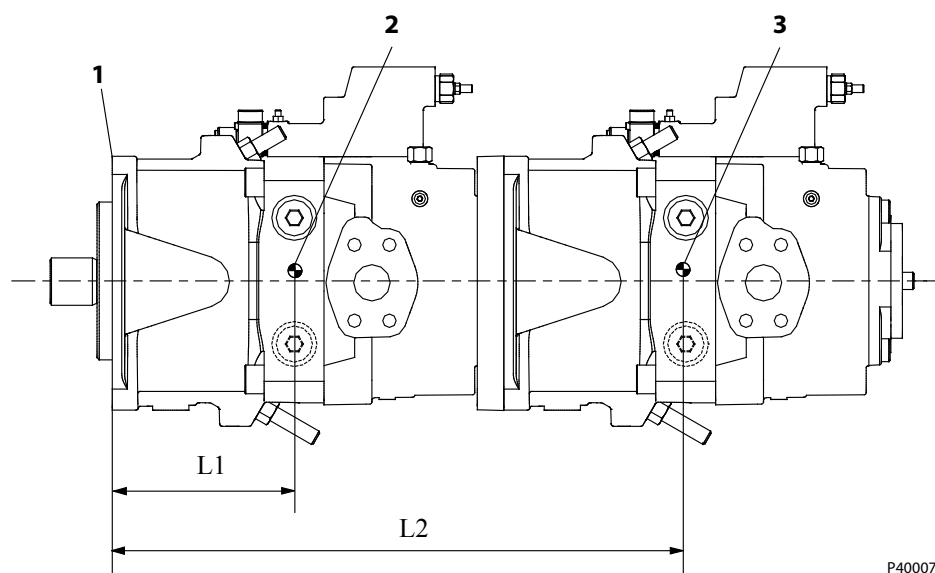

P400078

1. Mounting Flange                      2. Center of Gravity (CG), Pump 1                      3. Center of Gravity (CG), Pump 2
- **Shock load formula**  $M_S = G_S \cdot K \cdot (W_1 \cdot L_1 + W_2 \cdot L_2 + \dots + W_n \cdot L_n)$
  - **Continuous load formula**  $M_C = G_C \cdot K \cdot (W_1 \cdot L_1 + W_2 \cdot L_2 + \dots + W_n \cdot L_n)$

**SI units**

$M_S$  = Shock load moment (N·m)

$M_C$  = Continuous (vibratory) load moment (N·m)

$G_S$  = Acceleration due to external shock (G's)

$G_C$  = Acceleration due to continuous vibration (G's)

K = Conversion factor = 0.00981

$W_n$  = Mass of n<sup>th</sup> pump (kg)

$L_n$  = Distance from mounting flange to n<sup>th</sup> pump CG (mm)

## Parameters

### Understanding and minimizing system noise

Noise is transmitted in fluid power systems in two ways: as fluid borne noise, and structure borne noise.

**Fluid-borne noise** (pressure ripple or pulsation) is created as pumping elements discharge oil into the pump outlet. It is affected by the compressibility of the oil, and the pump's ability to transition pumping elements from high to low pressure. Pulsations travel through the hydraulic lines at the speed of sound until there is a change (such as an elbow) in the line. Amplitude varies with overall line length and position.

**Structure borne noise** is transmitted wherever the pump casing connects to the rest of the system. The way system components respond to excitation depends on their size, form, material, and mounting.

---

[System lines and pump mounting can amplify pump noise.](#)

---

**Follow these suggestions to help minimize noise in your application:**

- Use flexible hoses.
- Limit system line length.
- If possible, optimize system line position to minimize noise.
- If you must use steel plumbing, clamp the lines.
- If you add additional support, use rubber mounts.
- Test for resonance in the operating range; if possible avoid them.

### D1P installation

Series D1 pumps may be installed in any position. To optimize inlet conditions, install the pump at an elevation below the minimum reservoir fluid level. Design inlet plumbing to maintain inlet pressure within prescribed limits (see Inlet pressure limits on [D1 pump specifications](#))

Fill the pump housing and inlet line with clean fluid during installation. Connect the case drain line to the uppermost drain port (L1, L2 or L3) to keep the housing full during operation.

To allow unrestricted flow to the reservoir, use a dedicated drain line. Connect it below the minimum reservoir fluid level and as far away from the reservoir outlet as possible. Use plumbing adequate to maintain case pressure within prescribed limits (see case pressure limits on [D1 pump specifications](#)).

### D1P filtration

To prevent damage to the pump, including premature wear, fluid entering the pump inlet must be free of contaminants. Series D1 pumps require system filtration capable of maintaining fluid cleanliness at class 20/18/15 according to ISO 4406-1999 or better.

Danfoss Power Solutions does not recommend suction line filtration. Suction line filtration can cause high inlet vacuum, which limits pump operating speed. Instead we recommend a 125 µm (150 mesh) screen in the reservoir covering the pump inlet. This protects the pump from coarse particle ingestion.

Return line filtration is the preferred method for open circuit systems. Consider these factors when selecting a system filter:

- Cleanliness specifications
- Contaminant ingress rates
- Flow capacity
- Desired maintenance interval

Typically, a filter with a beta ratio of  $\beta_{10} = 10$  is adequate. However, because each system is unique, only a thorough testing and evaluation program can fully validate the filtration system.

For more information, see Danfoss Power Solutions publication **BC152886482150** *Design Guidelines for Hydraulic Fluid Cleanliness*.

## Parameters

### Reservoir

The reservoir provides clean fluid, dissipates heat, and removes entrained air from the hydraulic fluid. It allows for fluid volume changes associated with fluid expansion and cylinder differential volumes. Minimum reservoir capacity depends on the volume needed to perform these functions. Typically, a capacity of one to three times the pump flow (per minute) is satisfactory.

Locate the reservoir outlet (suction line) near the bottom, allowing clearance for settling foreign particles. Place the reservoir inlet (return lines) below the lowest expected fluid level, as far away from the outlet as possible.

### Sizing Equations

Use these equations to help choose the right pump size and displacement for your application.

#### Based on SI units

**Flow** Output flow  $Q = \frac{V_g \cdot n \cdot \eta_v}{1000}$  (l/min)

**Torque** Input torque  $M = \frac{V_g \cdot \Delta p}{20 \cdot \pi \cdot \eta_m}$  (N·m)

**Power** Input power  $P = \frac{M \cdot n \cdot \pi}{30\,000} = \frac{Q \cdot \Delta p}{600 \cdot \eta_t}$  (kW)

#### Based on US units

Output flow  $Q = \frac{V_g \cdot n \cdot \eta_v}{231}$  (US gal/min)

Input torque  $M = \frac{V_g \cdot \Delta p}{2 \cdot \pi \cdot \eta_m}$  (lbf·in)

Input power  $P = \frac{M \cdot n \cdot \pi}{198\,000} = \frac{Q \cdot \Delta p}{1714 \cdot \eta_t}$  (hp)

### Variables

SI units [US units]

$V_g$  = Displacement per revolution  $\text{cm}^3/\text{rev}$  [ $\text{in}^3/\text{rev}$ ]

$P_o$  = Outlet pressure bar [psi]

$P_i$  = Inlet pressure bar [psi]

$\Delta p$  =  $p_o - p_i$  (system pressure) bar [psi]

$n$  = Speed  $\text{min}^{-1}$  (rpm)

$\eta_v$  = Volumetric efficiency

$\eta_m$  = Mechanical efficiency

$\eta_t$  = Overall efficiency ( $\eta_v \cdot \eta_m$ )

**Control Type**

**NPNN (Pressure Compensated Control)**

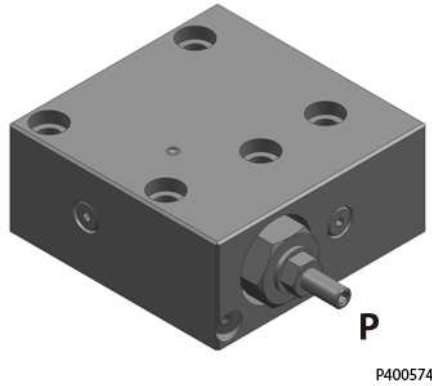

D1P 130/145/193/260+NPNN

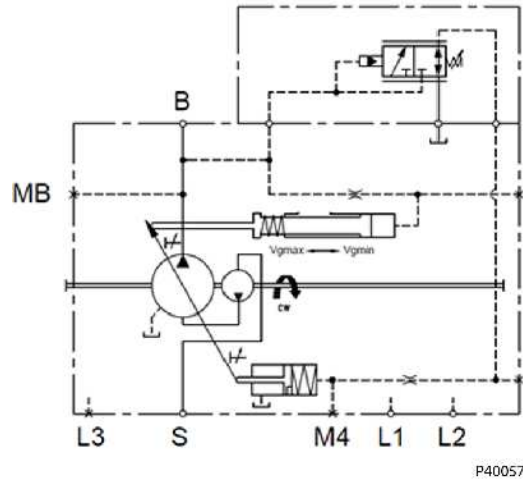

**Pressure Compensated Control (P) Principle**

The P control design maintains a constant pressure in the hydraulic circuit as flow varies. The P control modulates pump flow accordingly to maintain system pressure at the P setting as the P adjusting screw and spring defines.

**Pressure Compensated Control (P) Operation**

When system pressure, acting on the non-spring end of the P spool, overcomes the force of the P spring, the spool shifts porting system pressure to the servo piston and the swashplate angle decreases. When system pressure drops below the P setting, the P spring shifts the spool in the opposite direction connecting the servo piston to pump case and the swashplate angle increases. The swashplate is maintained at whatever angle is required to keep system pressure at the P setting.

*P characteristic*

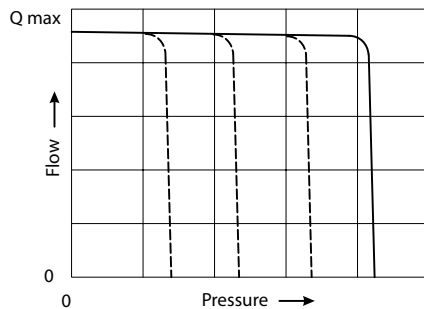

**Warning**

A relief valve is required to be installed in the pump outlet for additional system protection. Failure to install the relief valve can lead to system damage and/or injury.



**Control Type****Response/Recovery**

<b>Pressure Compensated (PC) Control Response/Recovery Times* @80°C, 350 bar, 1500rpm</b>		
<b>Frame Size</b>	<b>Response (msec)</b>	<b>Recovery (msec)</b>
130cc	150	270
145cc	150	270
193cc <sup>1</sup>	280	500
260cc	154	327

<sup>1</sup> Tested at 1800rpm

---

Values may vary depending on application conditions. For more information, please contact Danfoss Power Solutions.

---

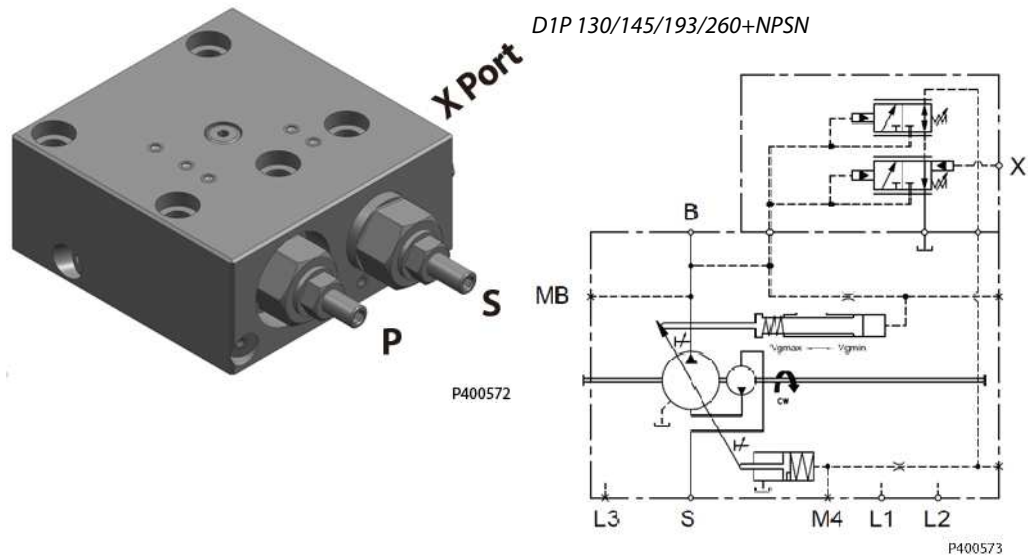
**Control Type**
**NPSN (Pressure Compensated Control + Load Sensing Control)**

**Pressure Compensated Control (P) Principle and Operation**

Please refer to [NPNN \(Pressure Compensated Control\)](#) on page 32

**Load Sensing Control (S) Principle**

The S control design matches pump flow with system demand. The S control senses the flow demand of the system as a pressure drop across the external control valve (1).

As (1) opens and closes, the pressure difference ( $\Delta$ ) across the valve changes. When opening, the  $\Delta$  decreases. When closing, the  $\Delta$  increases. The S control then increases or decreases pump flow to the system until the pressure  $\Delta$  becomes equal to the S setting as defined by the S adjusting screw and spring.

**Load Sensing Control (S) Operation**

Through internal porting, system pressure [upstream of (1)] is applied to the non-spring end of the S spool, and through hydraulic line connected at port X, load pressure [downstream of (1)] is applied to the spring end. This arrangement allows the S spool to act on the  $\Delta$  between system pressure and load pressure. The S spring sets the threshold of operation (S setting).

Because the swashplate is biased to maximum angle, the pump attempts to deliver full flow to the hydraulic system. When the flow being delivered exceeds demand, the pressure  $\Delta$  across the (1) is great enough to overcome spring force and shift the S spool porting system pressure to the servo piston. The pump de-strokes reducing flow until the  $\Delta$  across the (1) becomes equal to the S setting.

When flow being delivered is less than demand, the  $\Delta$  across the (1) drops below the S setting and the S spring shifts the spool connecting the servo piston to pump case. The pump strokes increasing flow until the  $\Delta$  across the (1) becomes equal to the S setting.

When the external control valve (1) is placed in neutral, it connects the LS signal line to drain. With no LS pressure acting on the non-spring end of the LS spool, the pump adjusts stroke to whatever position necessary to maintain system pressure at the LS setting. The pump is now in low pressure standby mode.

(1) is not in the scope of supply.

## Control Type

### S characteristic

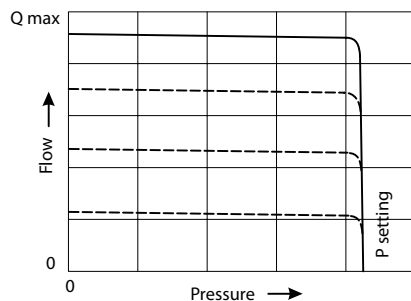

### Warning

A relief valve is required to be installed in the pump outlet for additional system protection. Failure to install the relief valve can lead to system damage and/or injury.

### NPSN Priority

The Pressure Compensated Control (P) has priority over the Load Sensing Control (S).

### Response/Recovery

Load Sensing (LS) Response/Recovery Times @80°C, 1500rpm, LS Setting at 25 bar		
Frame Size	Response (msec)	Recovery (msec)
130cc	260	360
145cc	260	360
193cc <sup>1</sup>	233	264
260cc	309	327

<sup>1</sup> Tested with a LS setting of 20bar

Values may vary depending on application conditions. For more information, please contact Danfoss Power Solutions

**Control Type**

**NPNR (Pressure Compensated Control + Remote Pressure Compensated Control)**

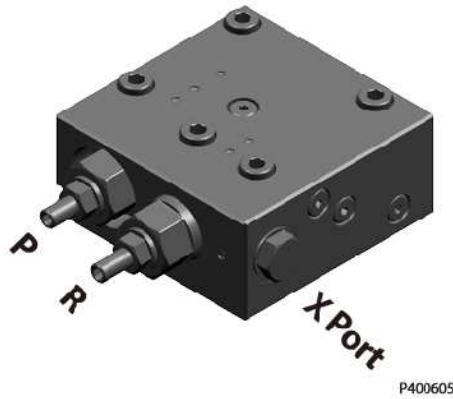

D1P 130/145/193/260+NPNR

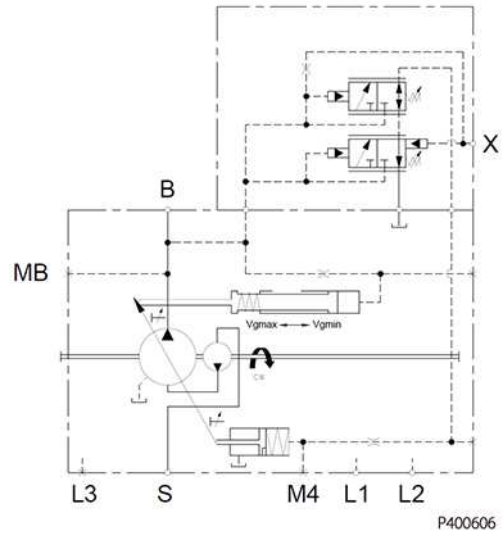

**Pressure Compensated Control (P) Principle and Operation**

Please refer to [NPNN \(Pressure Compensated Control\)](#) on page 32.

**Remote Pressure Compensated Control (R) Principle**

The remote PC control is a two-stage control that allows multiple PC settings. Remote PC controls are commonly used in applications requiring low and high pressure PC operation.

For this control, Danfoss recommends a load sense setting of 25 bar.

**Remote Pressure Compensated Control (R) Operation**

The remote PC control uses a pilot line connected to an external hydraulic valve. The external valve changes pressure in the pilot line, causing the PC control to operate at a lower pressure. When the pilot line is vented to reservoir, the pump maintains pressure at the load sense setting. When pilot flow is blocked, the pump maintains pressure at the PC setting. An on-off solenoid valve can be used in the pilot line to create a low-pressure standby mode. A proportional solenoid valve, coupled with a microprocessor control, can produce an infinite range of operating pressures between the low pressure standby setting and the PC setting.

*R characteristic*

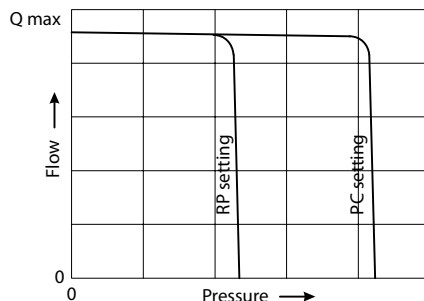

## Control Type

 **Warning**

---

A relief valve is required to be installed in the pump outlet for additional system protection. Failure to install the relief valve can lead to system damage and/or injury.

---

### **NPNR Priority**

When the pump's X-port is vented to tank, or limited to some pressure setting via a remote valve, the remote pressure compensator function will control the maximum outlet pressure of the pump. If the pump's outlet pressure reaches the pressure setting of the pressure compensator (PC) function, the PC function will take priority and limit the pump's maximum pressure.

**Control Type**

**TPSN (Power Control + Pressure Compensated Control + Load Sensing Control)**

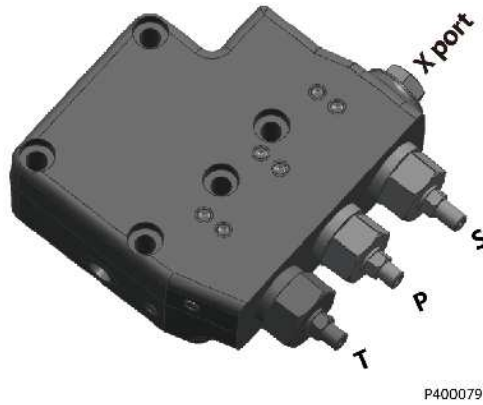

D1P 130/145/193/260+TPSN

\*Control oil filter is optional

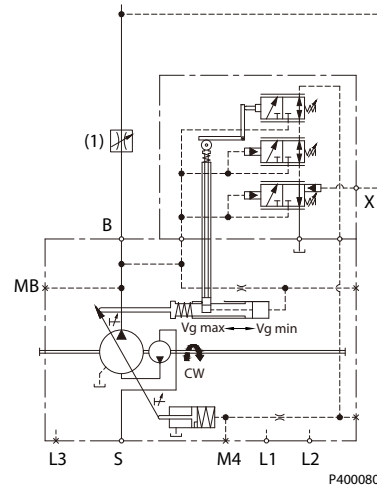

**Power Control (T) Principle**

The power control regulates the displacement of the pump depending on the working pressure so that a given drive power is not exceeded at constant drive speed, this function can prevent engine stall or protect electric generator.

$$P_B \cdot V_g = C$$

$P_B$  = working pressure  
 $V_g$  = displacement  
 $C$  = constant

The precise control with a hyperbolic control characteristic, provides an optimum utilization of available power.

**Power Control (T) Operation**

The working pressure acts on a rack-pivot via a roller jack which produces a rotating torque, an externally adjustable spring force counteracts this which determines the power setting.

If the moment generated by working pressure exceeds the moment generated by spring force, the control valve is actuated by the rack-pivot, and pump reduces displacement. The lever length at the rack-pivot is shortened and the working pressure can increase at the same rate as the displacement decreases without the drive powers being exceeded.

$$(P_B \cdot V_g = C).$$

The hydraulic output power (characteristic T) is influenced by the efficiency of the pump.

## Control Type

*T characteristic*

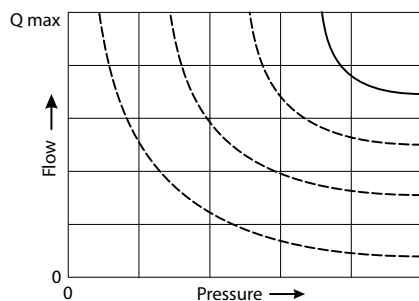

### **Pressure Compensated Control (P) Principle and Operation**

Please refer to [NPNN \(Pressure Compensated Control\)](#) on page 32

### **Load Sensing Control (S) Principle and Operation**

Please refer to [NPSN \(Pressure Compensated Control + Load Sensing Control\)](#) on page 34

### **TPSN Priority**

The Pressure Compensated Control (P) has priority over the Power Control (T), Power Control has priority over Load Sensing Control (S).

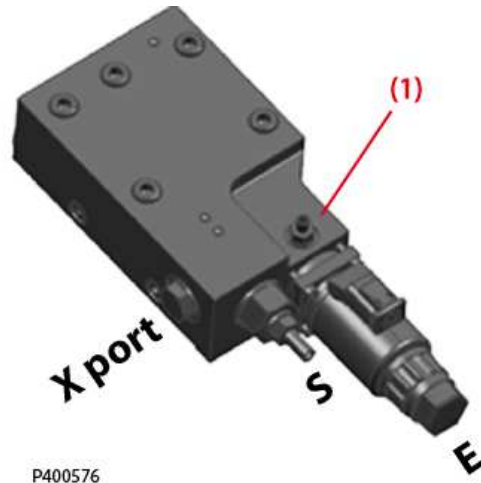
**Control Type**
**NNES (Electric Displacement Control + Load Sensing Control)**

**Warning**

(1) Adjustment is not permissible

D1P 130/145/193/260 NNES

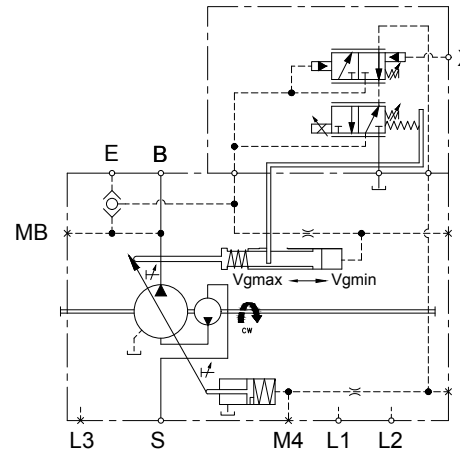
**Electric Displacement Control (E) Principle**

The electric displacement control uses an electric proportional solenoid valve to vary the pump's displacement from minimum displacement to maximum displacement or from maximum displacement to minimum displacement. The swashplate angle (pump displacement) is proportional to the electrical input signal (control current).

**Electric Displacement Control (E) Operation**

This control is current driven, requiring a Pulse Width Modulated (PWM) signal. Pulse width modulation allows more precise control of current to the solenoid. The PWM signal causes the solenoid pin to push against the E spool, which depressurizes the end of servo piston, the swashplate angle increases under the force of the bias piston

A swashplate feedback link provides swashplate position force to the solenoid through the E spool's linear spring. The control reaches equilibrium when the position of the swashplate spring feedback force exactly balances the input command solenoid force from the operator. As working pressure changes with load, the control and servo/swashplate system work constantly to maintain the commanded position of the swashplate.

**Electric Displacement Control (E) Operating Instruction**

To make sure the electric displacement control works properly, a minimum control pressure of 30 bar [435 psi] is required. The required control pressure is taken either from the working pressure, or from the externally applied control pressure at the E port.

If you can't make sure that the working pressure is above 30 bar all the time, then a minimum of 30bar [435 psi] pressure supply at the E port is mandatory in order to control the displacement of the pump at all times. This pressure supply can be provided from different sources, such as an additional small gear or piston pump and a relief valve, or an accumulator.

If E port is not connected, remove the shuttle valve



## Control Type

*Typical operating curve*

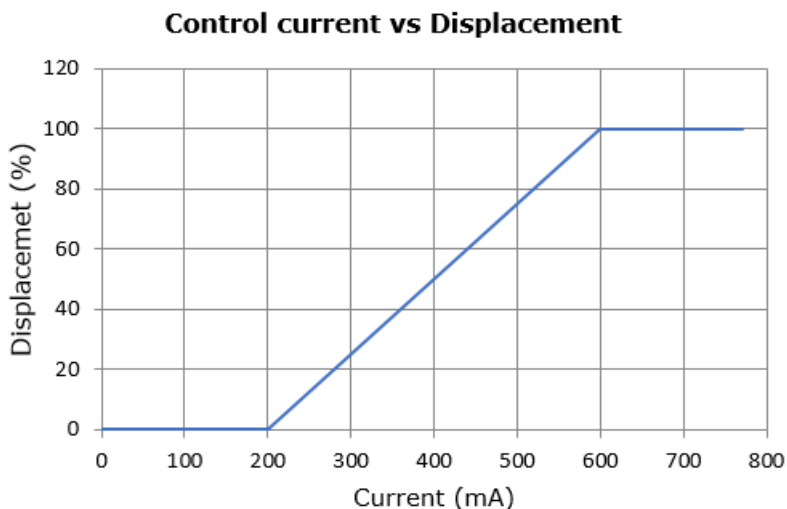

### Hysteresis

<b>EDC Hysteresis<sup>1</sup></b>	
Input hysteresis	<4.5%
Output hysteresis @50% displacement	<4.0%

<sup>1</sup> Values may vary depending on application conditions. For more information, please contact Danfoss Power Solutions

### Response/Recovery

<b>Response/Recovery Times @ 1500rpm (50°C)<sup>1</sup></b>		
Recovery 0%-100%	130cc (263 bar)	260 msec
	145cc (263 bar)	260 msec
	193cc (160 bar)	272 msec
	260cc (200 bar)	370 msec
Response 100%-0%	130cc (263 bar)	390 msec
	145cc (263 bar)	390 msec
	193cc (160 bar)	186 msec
	260cc (200 bar)	390 msec

### MOR

Each Electric Displacement Control (EDC) is equipped with a Manual Over Ride (MOR) function for temporary actuation of the control to aid in diagnostics, even if insufficient or no current is supplied to the solenoid actuator. Initial activation of the MOR function will require a higher force to overcome the sticking effect between the pin and O-ring seal. Repeated activation of this functionality should provide better controllability.

**Control Type**

**Warning**

Do not actuate the MOR unless the machine is in a "SAFE" mode. Unintended MOR operation will cause the pump to go into stroke, use only for diagnosis purposes.

**Solenoid Specification**
*Technical data - Solenoid*

<b>Voltage</b>	24V (±20%)
<b>Start current at Vg min.</b>	200 mA
<b>End Current at Vg max.</b>	600 mA
<b>Maximum current</b>	770 mA
<b>Coil Resistance @ 20 °C [70 °F]</b>	22.7 Ω
<b>PWM Range</b>	70~200 Hz
<b>PWM Frequency (preferred)*</b>	100 Hz
<b>IP Rating (IEC 60 529) + DIN 40 050, part 9</b>	IP 67
<b>IP Rating (IEC 60 529) + DIN 40 050, part 9 with mating connector</b>	IP 69K

\* PWM signal required for optimum control performance

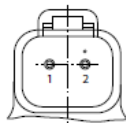
**Mating connector for Solenoid**

Description	Ordering Number	Quantity
Mating Connector	DEUTSCH DT06-2S	1
Wedge Lock	DEUTSCH W2S	1
Socket contact (16 and 18 AWG)	DEUTSCH 0462-201-16141	2
Danfoss mating connector kit	K29657	1
The mating connector is not included in the delivery contents, this can be delivered by Danfoss on request.		

Plug polarity is not necessary (Ex. either pin 1 or pin 2 can be used as positive).

**Compatible PLUS+1® controllers(see below):**

MC012	AI152986480902
MC024	AI152986480953
MC038	AI152886480992

**Control Type**

MC050	AI152986480864
MC088	AI152886480776

For further information: please visit: <http://www.danfoss.com/Products/MobileElectronics/index.htm>

**Standard EDC Valve**

The position of the connector can be changed by turning the solenoid body. Proceed as follows:

1. Loosen protection cap (1).
2. Loosen lock nut (2).
3. Turn the solenoid body (3) to the desired position.
4. Tighten the lock nut (2).
5. Tighten the protection cap (1).

Tightening Torque of lock nut:  $5 \pm 1 \text{ N}\cdot\text{m}$  [ $44.25 \pm 8.85 \text{ lbf}\cdot\text{in}$ ]

*Standard EDC Valve*

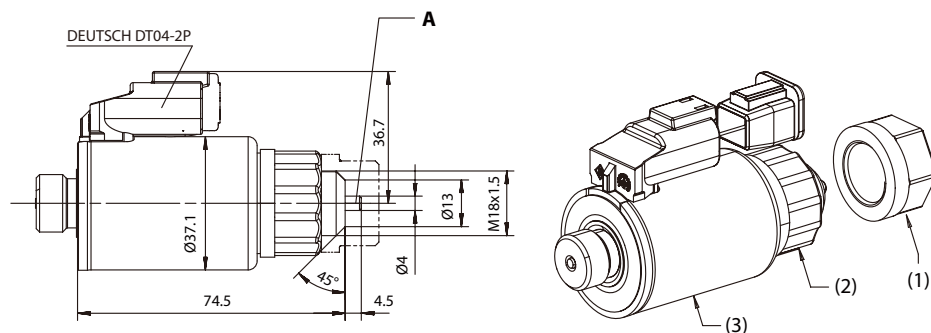

<b>A - Actuation Forces</b>	
Breakaway Force (First actuation)	45 N [10.12 lbf] max.
Repeat of Actuation	25 N [5.62 lbf] max.

**NNES Priority**

Both the Electric Displacement Control (EDC) and the Load Sensing Control (LS) are used to control the pump's displacement. The pump will output the smallest displacement when both control functions are given control instruct.

**Control Type**

**TPE2/TPE5 (Power Control + Pressure Compensated Control + Electric Displacement Control)**



D1P 130/145+TPE5

D1P 193/260+TPE2

\*Control oil filter is optional

**Warning**

(1) Adjustment is not permissible

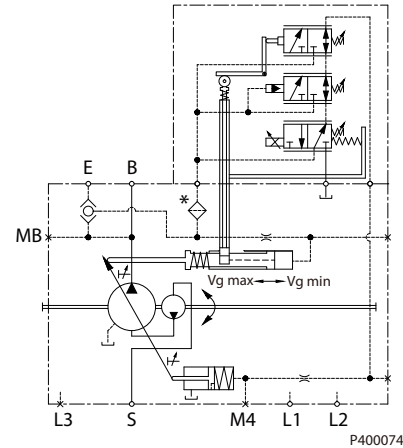

**Power Control (T) Principle and Operation**

Please refer to [TPSN \(Power Control + Pressure Compensated Control + Load Sensing Control\)](#) on page 38

**Pressure Compensated Control (P) Principle and Operation**

Please refer to [NPNN \(Pressure Compensated Control\)](#) on page 32

**Electric Displacement Control (E2/E5) Principle and Operation**

Please refer to [NNES \(Electric Displacement Control + Load Sensing Control\)](#) on page 40

**TPE2/TPE5 Priority**

The Pressure Compensated Control (P) has priority over the Power Control (T), and the Power Control (T) has priority over Electric Displacement Control (EDC).

**Control Type**

**NPE2/NPE0 (Pressure Compensated Control + Electric Displacement Control)**

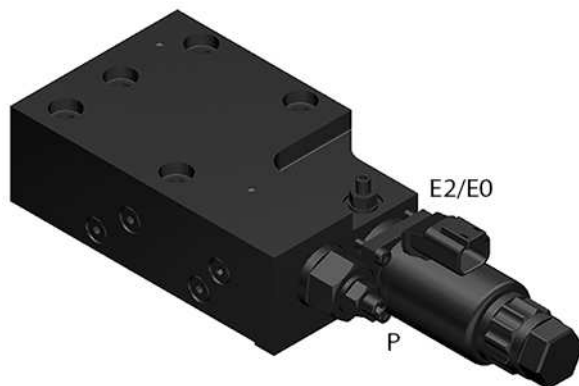

D1P with NPE2 (left); D1P with NPE0 (right)

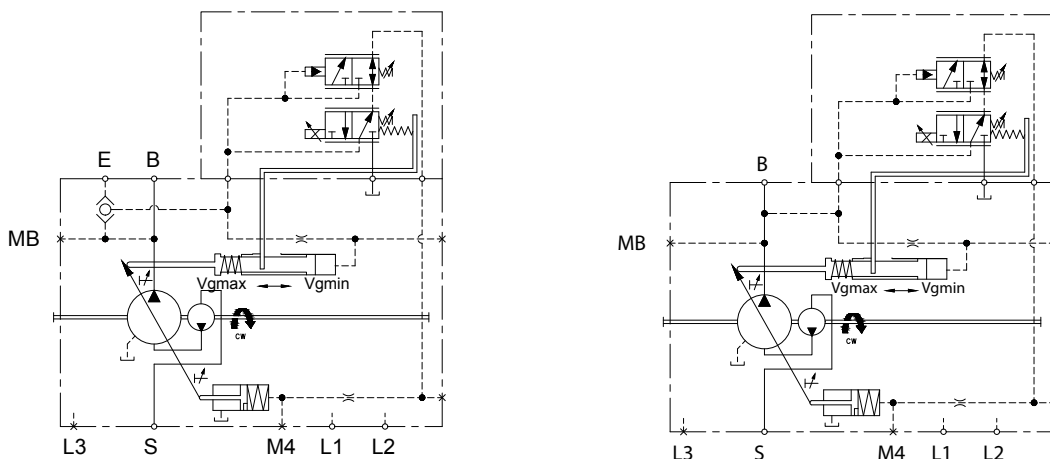

**Pressure Compensated Control (P) Principle and Operation**

Please refer to [NPNN \(Pressure Compensated Control\)](#) on page 32.

**Electric Displacement Control (E2/E0) Principle and Operation**

Please refer to [NNE5 \(Electric Displacement Control + Load Sensing Control\)](#) on page 40.

**Shuttle Valve/Pilot Supply**

Please refer to Electric Displacement Control (E) Operating Instruction section at [NNE5 \(Electric Displacement Control + Load Sensing Control\)](#) on page 40.

To determine if an external control pilot supply is needed, please consult your Danfoss Power Solutions representative.

D1P pumps configured with an NPE2 control will come with a shuttle valve installed at the E port. D1P pumps with an NPE0 control will not include the shuttle valve.

Installation Drawings

Size 130/145

Dimensions (mm) and port descriptions

**Size 130/145: TPSN w/o Charge Pump**

**Control : TPSN**

Power Control (T) + Pressure Compensated Control (P) + Load Sensing Control (S)

**Auxiliary flange : NN (No Auxiliary flange)**

**Charge pump : Without**

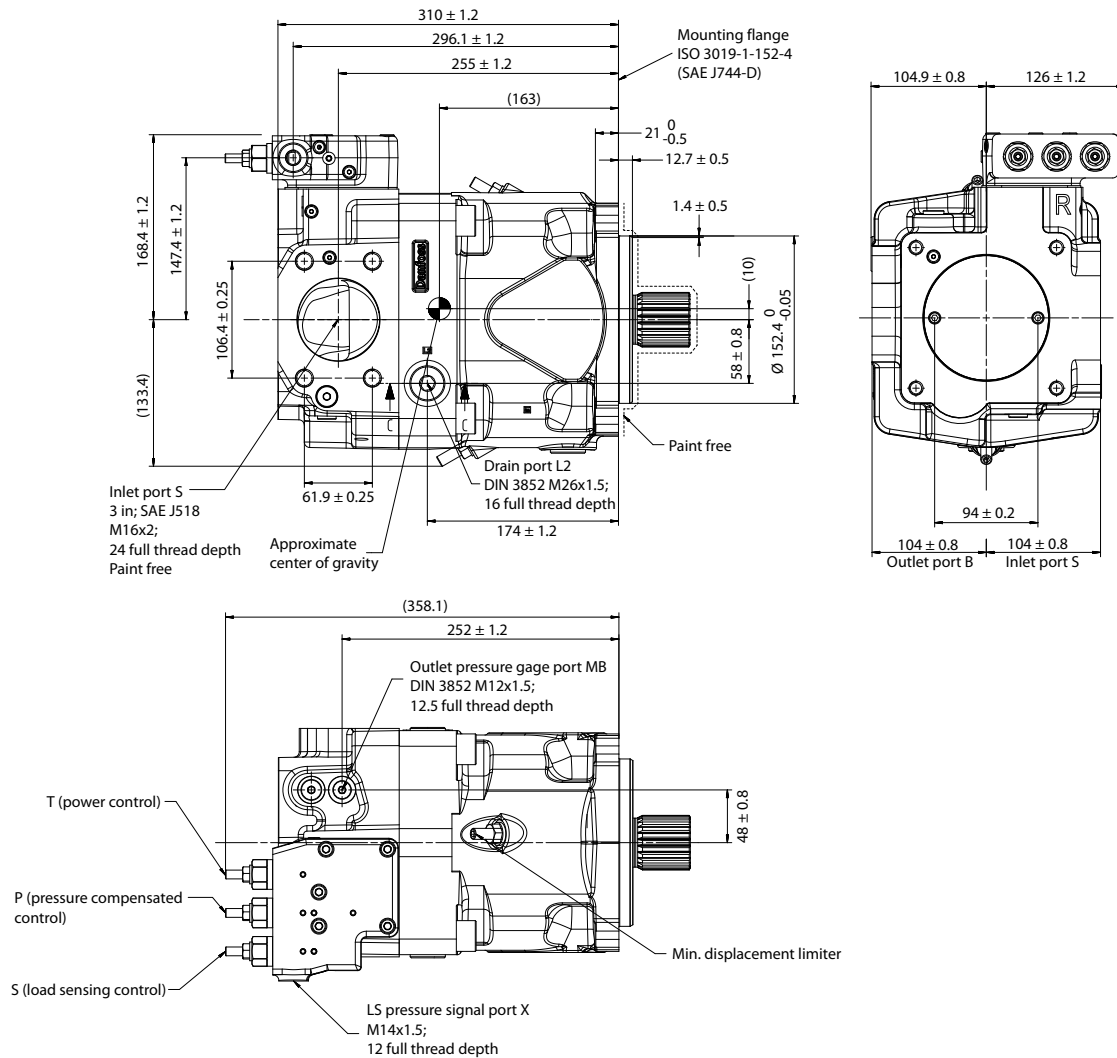

Before finalizing your design, please request a certified drawing.

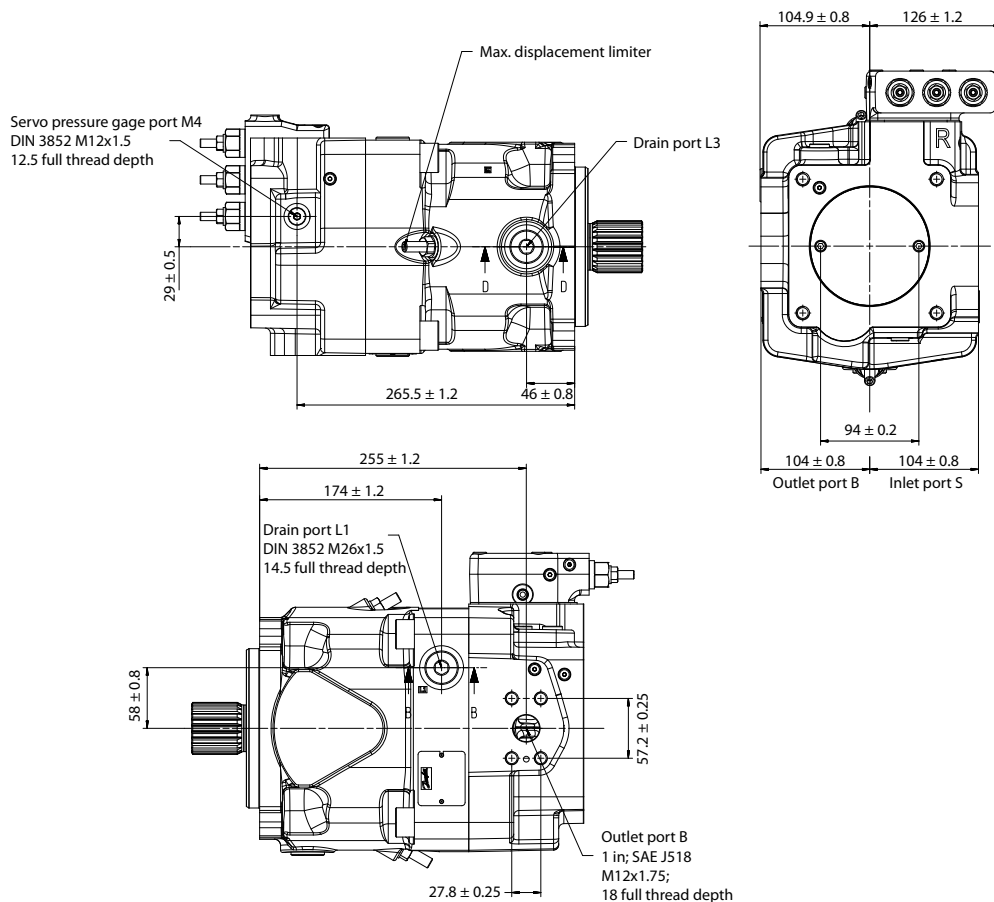
**Installation Drawings**

Before finalizing your design, please request a certified drawing.

**Port Descriptions**

Ports	Description	Standard	Size <sup>1)</sup>	Max. pressure (bar [psi])	State <sup>2)</sup>
<b>B</b>	Outlet port, Fixing thread	SAE J518, DIN13	1 in, M12 x 1.75; 18 deep	400 [5802]	O
<b>S</b>	Suction port, Fixing thread	SAE J518, DIN13	3 in, M16 x 2; 24 deep	2 [29]	O
<b>L<sub>1</sub>, L<sub>2</sub>, L<sub>3</sub></b>	Drain port	DIN 3852	M26 x 1.5; 14.5, 16, 14 deep	2 [29]	X <sup>3)</sup>
<b>M<sub>4</sub></b>	Measurement point, servo-piston chamber	DIN 3852	M12 x 1.5; 12.5 deep	400 [5802]	X
<b>M<sub>B</sub></b>	Measurement point, outlet port	DIN 3852	M12 x 1.5; 12.5 deep	400 [5802]	X
<b>X</b>	LS port	DIN 3852	M14 x 1.5; 12.5 deep	400 [5802]	O

<sup>1)</sup> For required torque, please refer to *D1P tightening torque* on page 94.

<sup>2)</sup> O = Open, must be connected (closed by plastic plug on delivery) / X = Closed (closed by metal plug on delivery).

<sup>3)</sup> Depending on installation position, one of L<sub>1</sub>, L<sub>2</sub> and L<sub>3</sub> must be connected (please refer to Installation Notes).

Installation Drawings

**Size 130/145: TPE5 w/o Charge Pump**

**Control : TPE5**

Power Control (T) + Pressure Compensated Control (P) + Electric Displacement Control (E5)

**Auxiliary flange : B1**

**Charge pump : Without**

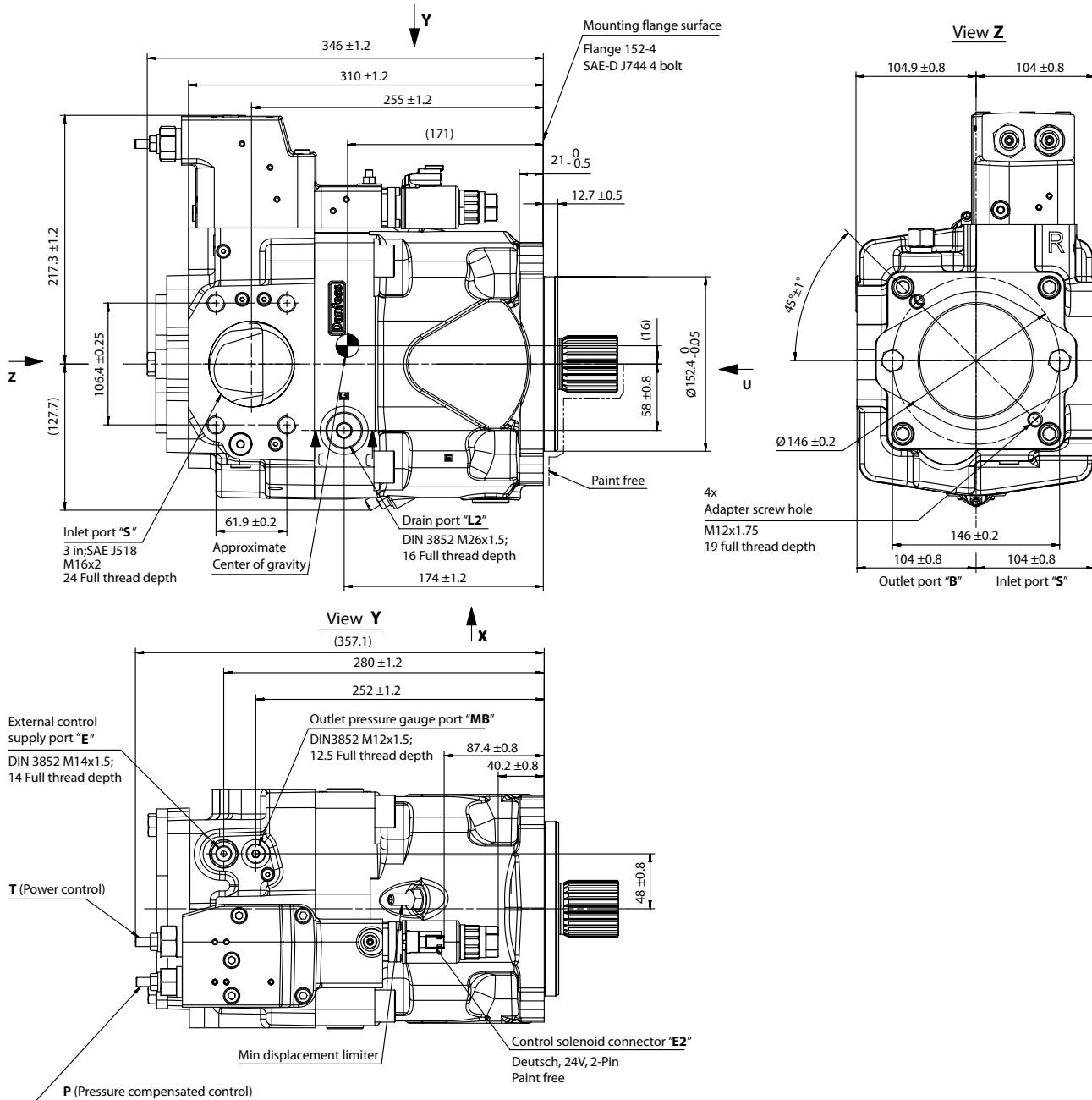

P400422

Before finalizing your design, please request a certified drawing.

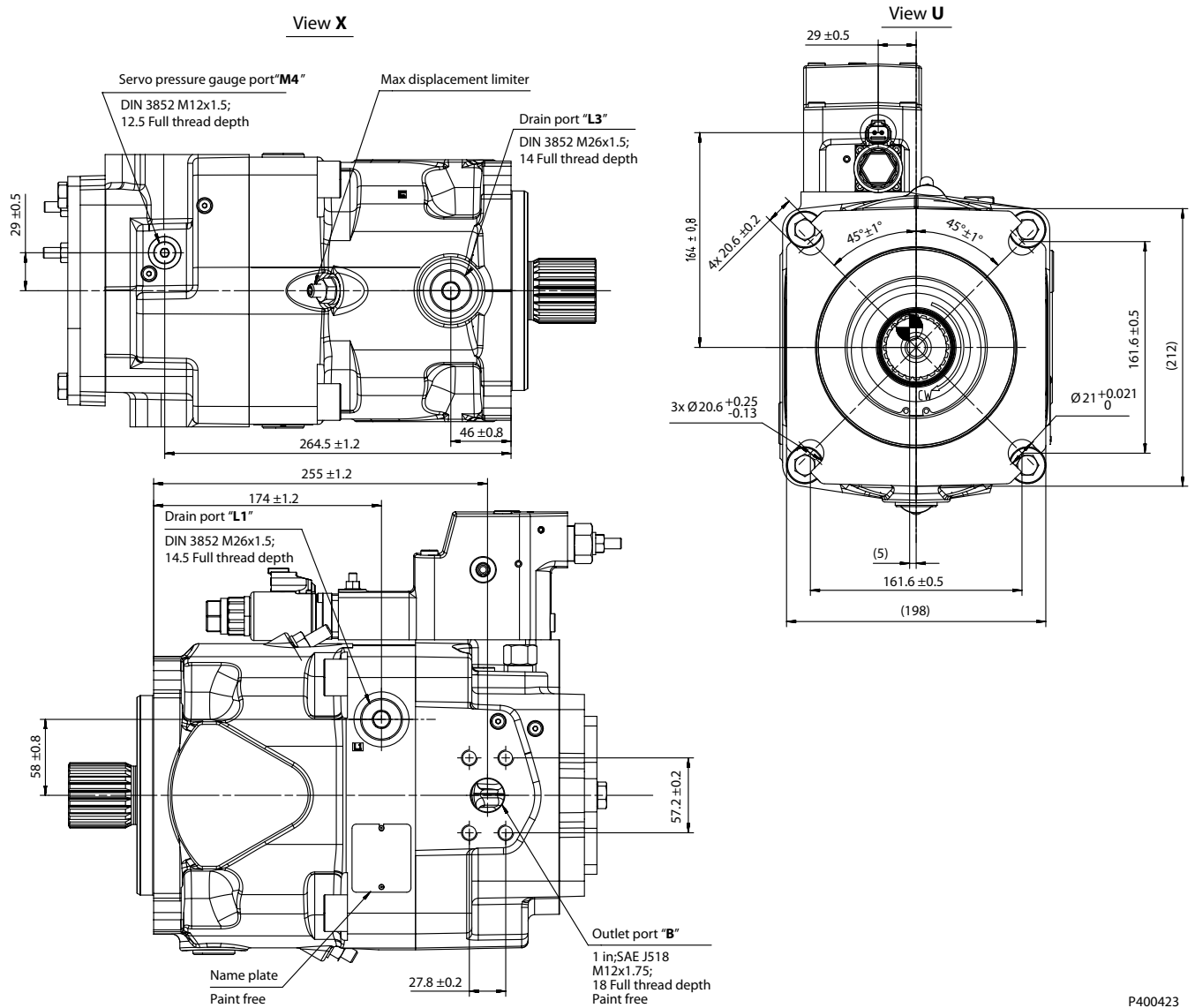

**Installation Drawings**

P400423

Before finalizing your design, please request a certified drawing.

**Port Descriptions**

Ports	Description	Standard	Size <sup>1)</sup>	Max. pressure (bar [psi])	State <sup>2)</sup>
<b>B</b>	Outlet port, Fixing thread	SAE J518, DIN13	1 in, M12 x 1.75; 18 deep	400 [5802]	O
<b>S</b>	Suction port, Fixing thread	SAE J518, DIN13	3 in, M16 x 2; 24 deep	2 [29]	O
<b>L<sub>1</sub>, L<sub>2</sub>, L<sub>3</sub></b>	Drain port	DIN 3852	M26 x 1.5; 14.5, 16, 14 deep	2 [29]	X <sup>3)</sup>
<b>M<sub>4</sub></b>	Measurement point, servo-piston chamber	DIN 3852	M12 x 1.5; 12.5 deep	400 [5802]	X
<b>M<sub>B</sub></b>	Measurement point, outlet port	DIN 3852	M12 x 1.5; 12.5 deep	400 [5802]	X
<b>E</b>	External control port	DIN 3852	M14 x 1.5; 12 deep	200 [2901]	X

<sup>1)</sup> For required torque, please refer to [DIP tightening torque](#) on page 94.

<sup>2)</sup> O = Open, must be connected (closed by plastic plug on delivery) / X = Closed (closed by metal plug on delivery).

<sup>3)</sup> Depending on installation position, one of L<sub>1</sub>, L<sub>2</sub> and L<sub>3</sub> must be connected (please refer to Installation Notes).

**Installation Drawings**

**Size 130/145: TPSN w/ Charge pump**

**Control : TPSN**

Power Control (T) + Pressure Compensated Control (P) + Load Sensing Control (S)

**Auxiliary flange : B1**

**Charge pump : With**

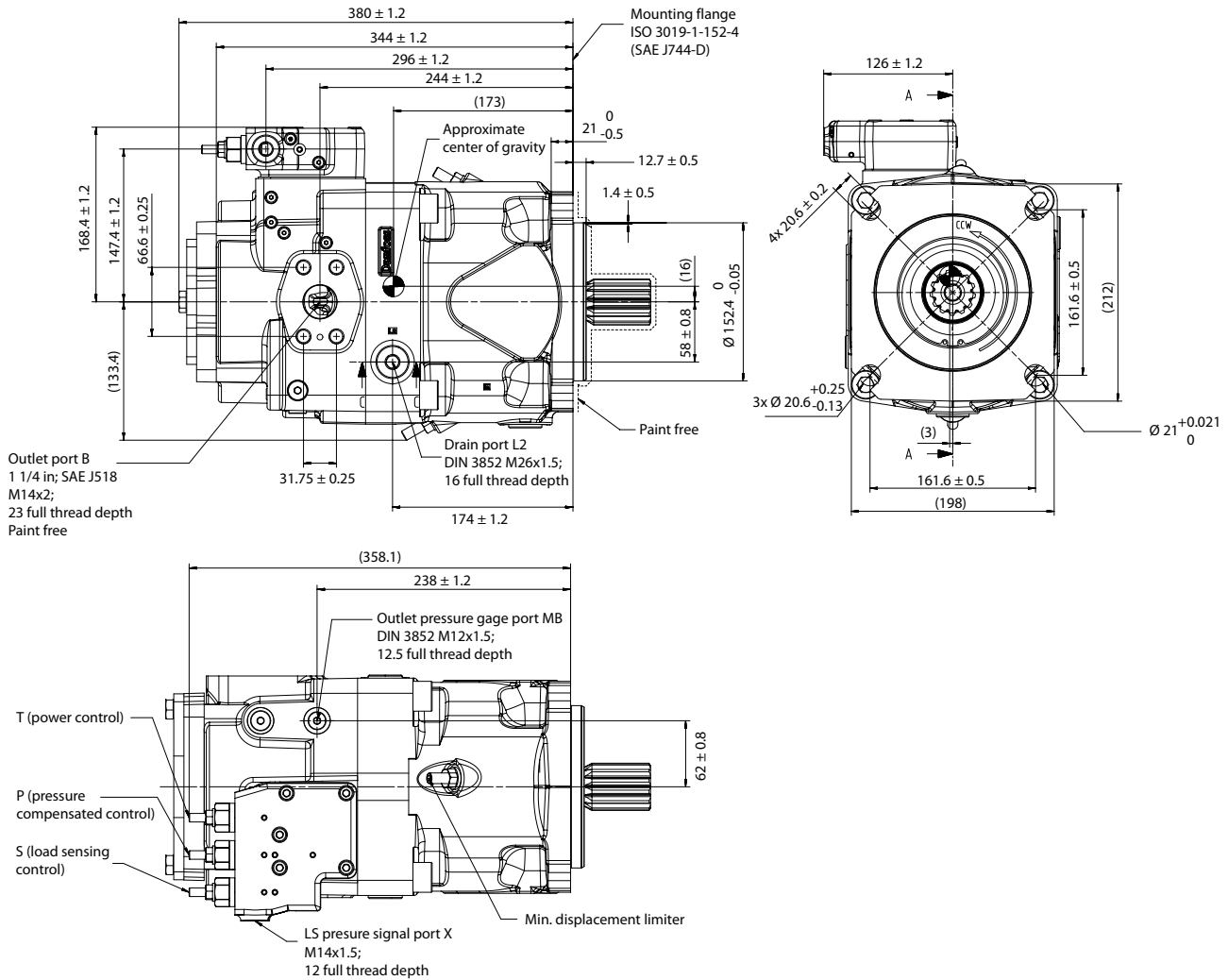

Before finalizing your design, please request a certified drawing.

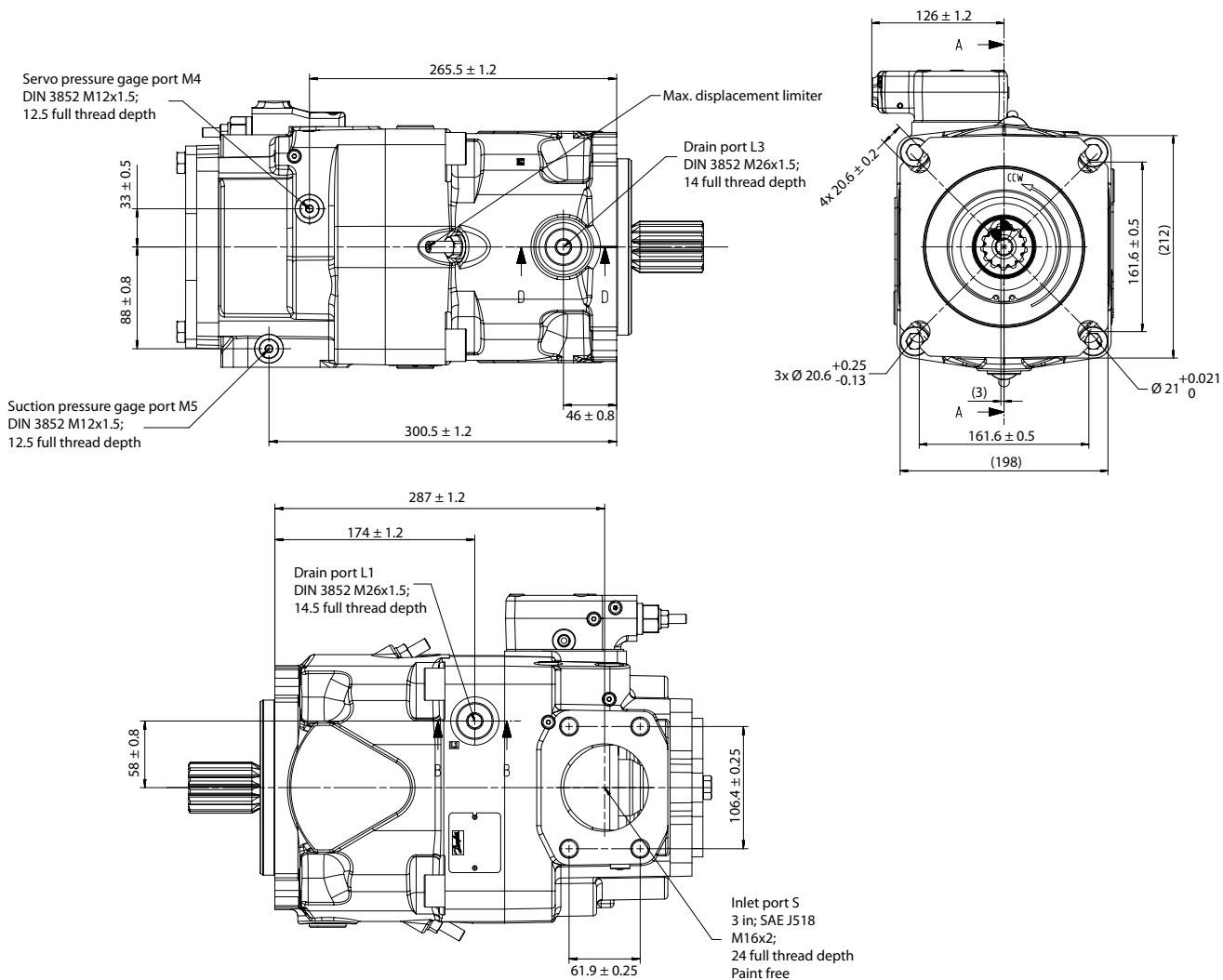
**Installation Drawings**

Before finalizing your design, please request a certified drawing.

**Port Descriptions**

Ports	Description	Standard	Size <sup>1)</sup>	Max. pressure (bar [psi])	State <sup>2)</sup>
<b>B</b>	Outlet port, Fixing thread	SAE J518, DIN13	1 ¼ in, M14 x 2; 23 deep	400 [5802]	O
<b>S</b>	Suction port, Fixing thread	SAE J518, DIN13	3 in, M16 x 2; 24 deep	2 [29]	O
<b>L<sub>1</sub>, L<sub>2</sub>, L<sub>3</sub></b>	Drain port	DIN 3852	M26 x 1.5; 14.5, 16, 14 deep	2 [29]	X <sup>3)</sup>
<b>M<sub>4</sub></b>	Measurement point, servo-piston chamber	DIN 3852	M12 x 1.5; 12.5 deep	400 [5802]	X
<b>M<sub>B</sub></b>	Measurement point, outlet port	DIN 3852	M12 x 1.5; 12.5 deep	400 [5802]	X
<b>X</b>	LS port	DIN 3852	M14 x 1.5; 12.5 deep	400 [5802]	X

<sup>1)</sup> For required torque, please refer to *D1P tightening torque* on page 94.

<sup>2)</sup> O = Open, must be connected (closed by plastic plug on delivery) / X = Closed (closed by metal plug on delivery).

<sup>3)</sup> Depending on installation position, one of L<sub>1</sub>, L<sub>2</sub> and L<sub>3</sub> must be connected (please refer to Installation Notes).

**Installation Drawings**

**Size 130/145: TPE5 w/ Charge Pump**

**Control : TPE5**

Power Control (T) + Pressure Compensated Control (P) + Electric Displacement Control (E5)

**Auxiliary flange : B1**

**Charge pump : With**

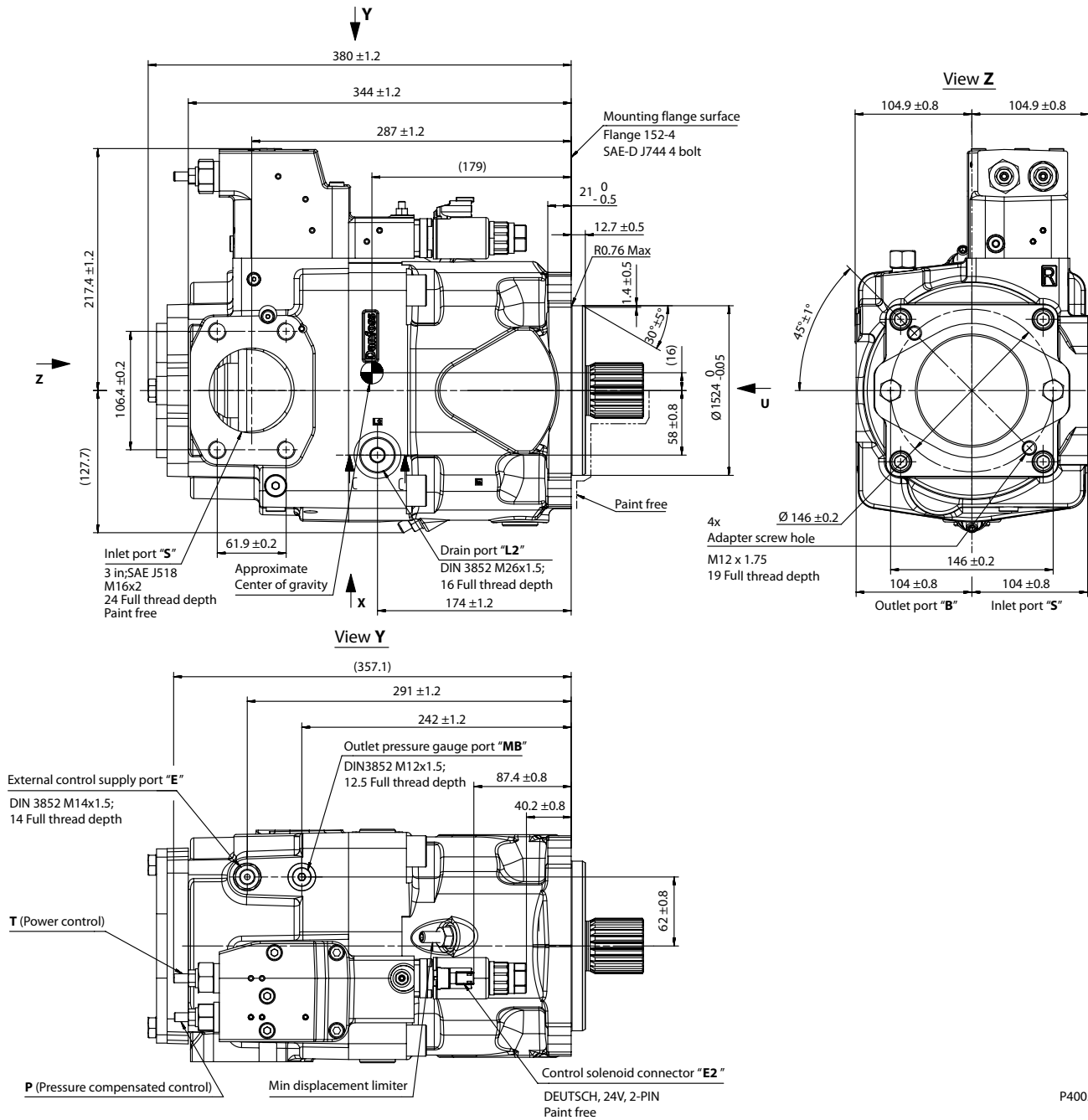

P400510

Before finalizing your design, please request a certified drawing.

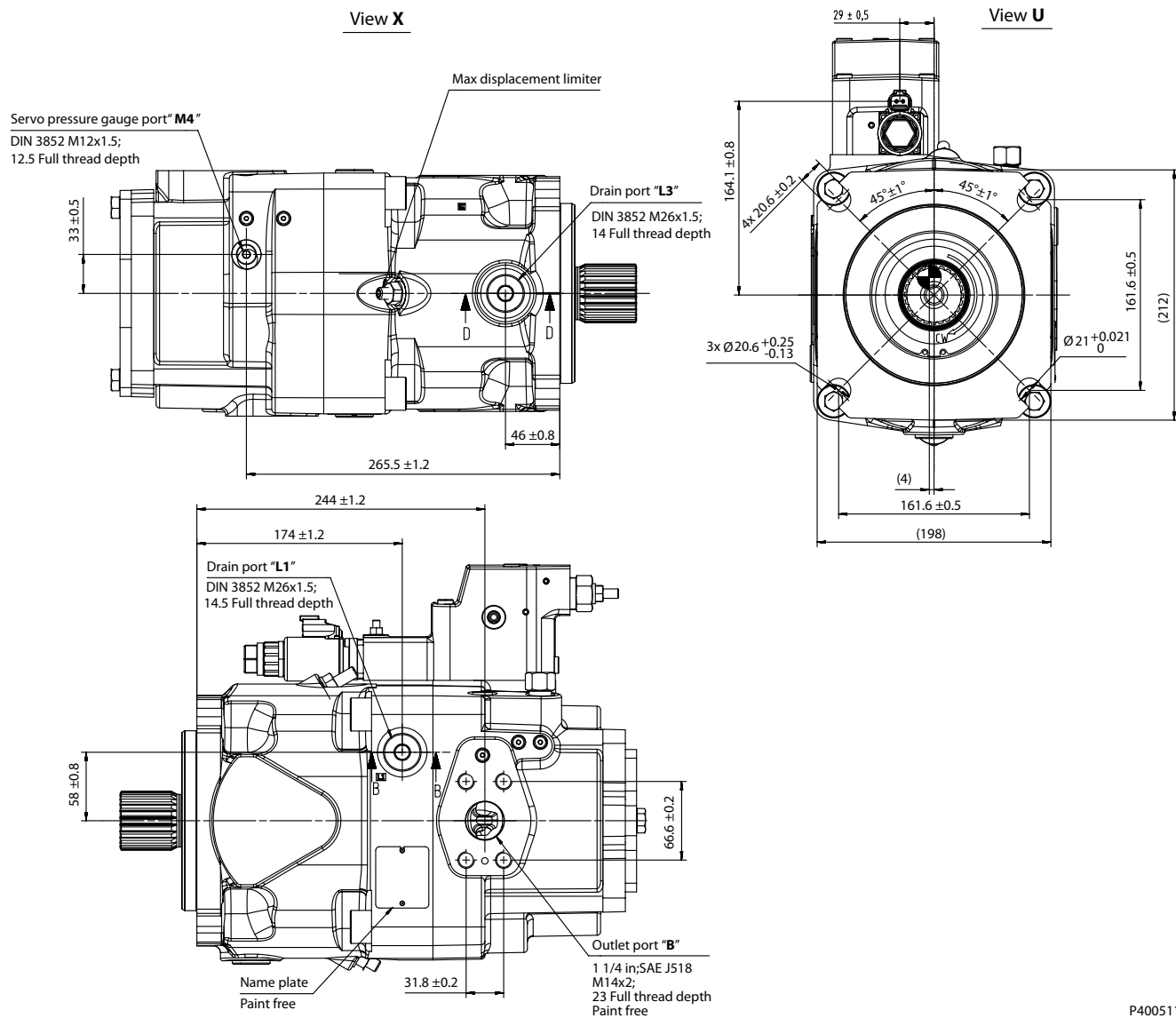
**Installation Drawings**

P400511

Before finalizing your design, please request a certified drawing.

**Port Descriptions**

Ports	Description	Standard	Size <sup>1)</sup>	Max. pressure (bar [psi])	State <sup>2)</sup>
<b>B</b>	Outlet port, Fixing thread	SAE J518, DIN13	1 ¼ in, M14 x 2; 23 deep	400 [5802]	O
<b>S</b>	Suction port, Fixing thread	SAE J518, DIN13	3 in, M16 x 2; 24 deep	2 [29]	O
<b>L<sub>1</sub>, L<sub>2</sub>, L<sub>3</sub></b>	Drain port	DIN 3852	M26 x 1.5; 14.5, 16, 14 deep	2 [29]	X <sup>3)</sup>
<b>M<sub>4</sub></b>	Measurement point, servo-piston chamber	DIN 3852	M12 x 1.5; 12.5 deep	400 [5802]	X
<b>M<sub>B</sub></b>	Measurement point, outlet port	DIN 3852	M12 x 1.5; 12.5 deep	400 [5802]	X
<b>E</b>	External control port	DIN 3852	M14 x 1.5; 12 deep	200 [2901]	X

<sup>1)</sup> For required torque, please refer to [DIP tightening torque](#) on page 94.

<sup>2)</sup> O = Open, must be connected (closed by plastic plug on delivery) / X = Closed (closed by metal plug on delivery).

<sup>3)</sup> Depending on installation position, one of L<sub>1</sub>, L<sub>2</sub> and L<sub>3</sub> must be connected (please refer to Installation Notes).

Installation Drawings

Input shaft

D1P 130/145 shaft specifications

Shaft torque and dimensions

Code	Description	Maximum Torque Rating	Drawing
T	Splined shaft DIN 5480, W50 x 2 x 30 x 24 x 9g	3100 N•m [27437 lbf•in]	<p>Mating coupling must not protrude beyond this point</p> <p>Paint free</p> <p>Spline data          Number of teeth : 24          Modules : 2          Pressure angle : 30°          Pitch Ø : Ø48          Type of fit : Flat root side          Per : DIN 5480 Class 9g</p> <p>10 ± 0.8</p> <p>12 ± 2</p> <p>5.2 ± 0.5</p> <p>Ø44.5 ± 0.12</p> <p>Ø49.6 ± 0.16</p> <p>Ø105.5 ± 0.25</p> <p>36 ± 2</p> <p>Full thd</p> <p>43.5 - 0.5</p> <p>45 ± 1</p> <p>(65)</p> <p>M16x2-6H THD<sup>(1)</sup></p> <p>Ø17 ± 0.2</p> <p>Ø23 ± 0.2</p> <p>Mounting flange          Flange 152-4          Per SAE J744</p> <p>P400085</p> <p><b>Min. active spline length<sup>(2)</sup>: 43.5 mm [1.71 in]</b></p>
S	Splined shaft SAE J744, 1 3/4 in. 13T, 8/16 DP	1528 N•m [13524 lbf•in]	<p>Mating coupling must not protrude beyond this point</p> <p>Paint free</p> <p>Spline data          Number of teeth : 13          Pitch fraction : 8/16          Pressure angle : 30°          Pitch Ø : Ø41.275          Type of fit : Fillet root side          Per : ANSI B92.1-1996.          Class 5</p> <p>10 ± 0.8</p> <p>12 ± 2</p> <p>5.2 ± 0.5</p> <p>Ø34.5 ± 0.1</p> <p>Ø44.45 ± 0.127</p> <p>Ø105.5 ± 0.25</p> <p>36 ± 2</p> <p>Full thd</p> <p>44 ± 1</p> <p>55 - 0.5</p> <p>(77)</p> <p>5/8-11 UNC-2B THD<sup>(1)</sup></p> <p>Ø17 ± 0.2</p> <p>Ø23 ± 0.2</p> <p>Mounting flange          Flange 152-4, Per SAE J744</p> <p>P400424</p> <p><b>Min. active spline length<sup>(2)</sup>: 55 mm [2.71 in]</b></p>

Installation Drawings

Shaft torque and dimensions (continued)

Code	Description	Maximum Torque Rating	Drawing
P	Straight keyed shaft, DIN 6885, AS14 x 9 x 80	1411 N·m [12488 lbf·in]	
K	SAE J744 (D/E) 3in straight keyed shaft, 0.4375 x 3.000 in	1787 N·m [15816 lbf·in]	

- 1) Center bore according to DIN 332 (thread according to DIN 13)
- 2) Minimum active spline length for the specified torque ratings

**Installation Drawings**

**Aux mounting flange**

**Size 130/145: Option NN (No Coupling)**

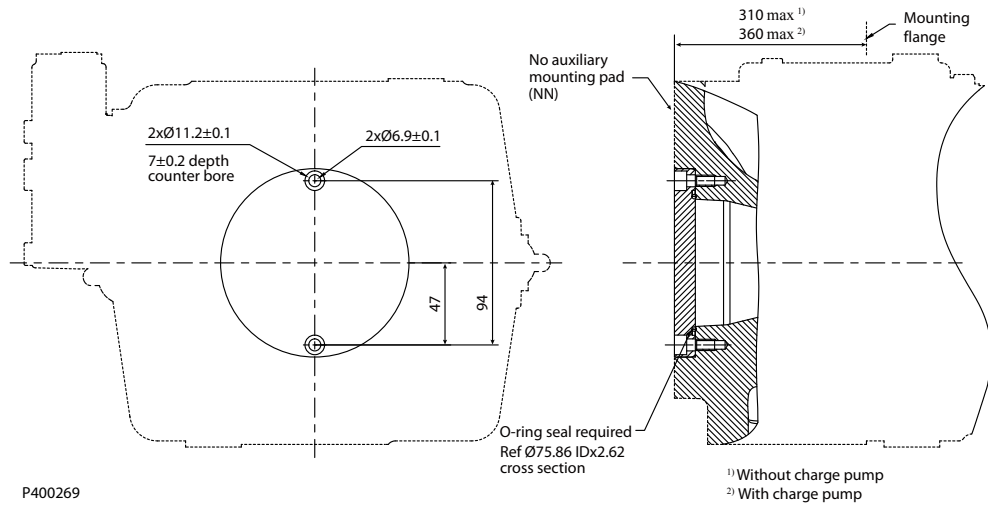

**Specifications**

Option	Coupling
NN	No coupling

**Size 130/145: Option A1 (SAE-A, 9 teeth)**

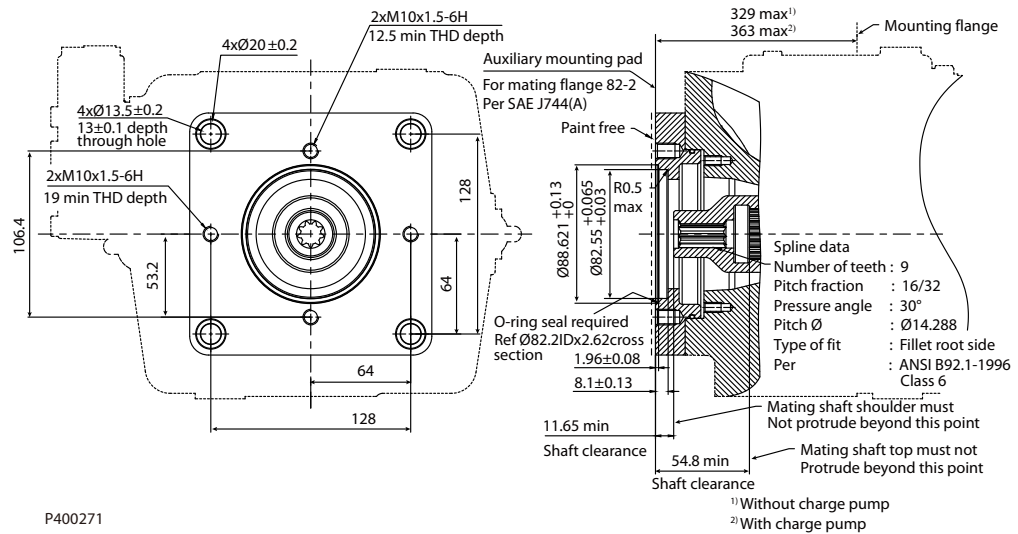

**Specifications**

Option	Coupling	Max torque
A1	5/8 in, 9T, 16/32 DP	205 N•m [1814.40 lbf•in]



**Installation Drawings**

**Size 130/145: Option A2 (SAE-A, 11 teeth)**

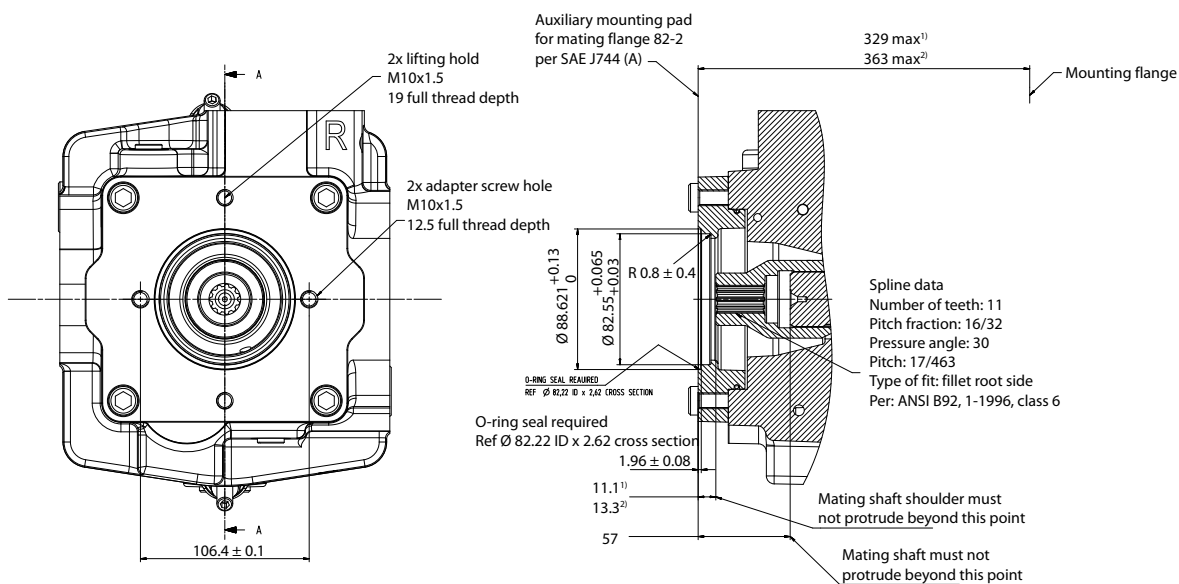

<sup>1)</sup>Without charge pump  
<sup>2)</sup>With charge pump

*Specifications*

Option	Coupling	Max torque
A2	3/4in, 11T, 16/32DP	Pending

Installation Drawings

**Size 130/145: Option B1 (SAE-B, 13 teeth)**

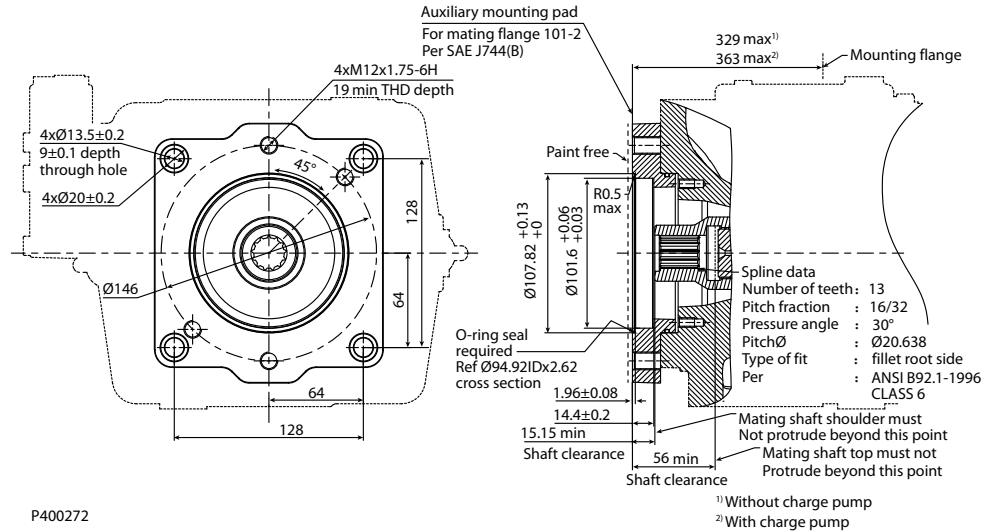

Specifications

Option	Coupling	Max torque
B1	7/8 in, 13T, 16/32 DP	411 N·m [3637.66 lbf·in]

**Size 130/145: Option B2 (SAE-B, 15 teeth)**

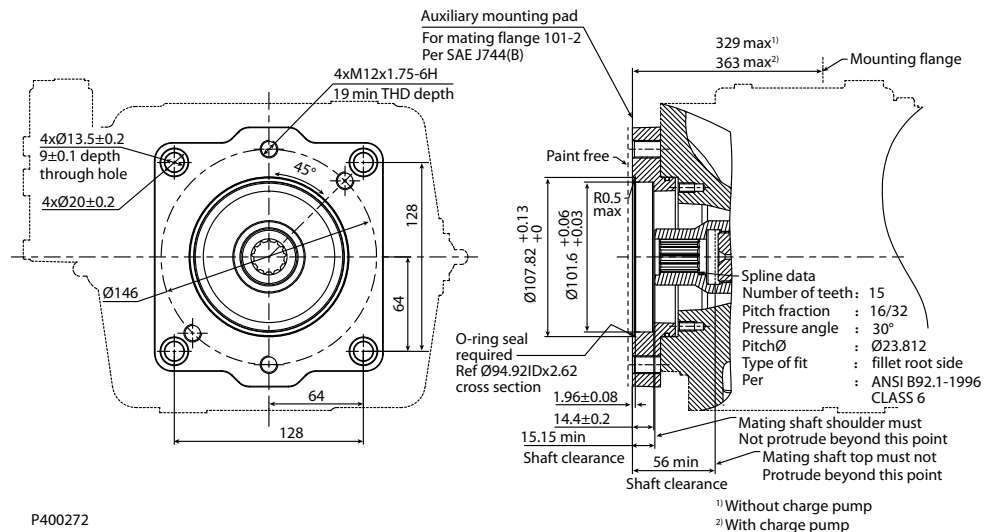

Specifications

Option	Coupling	Max torque
B2	1in, 15T, 16/32DP	Pending

Installation Drawings

**Size 130/145: Option BA (SAE-B, 13 teeth)**

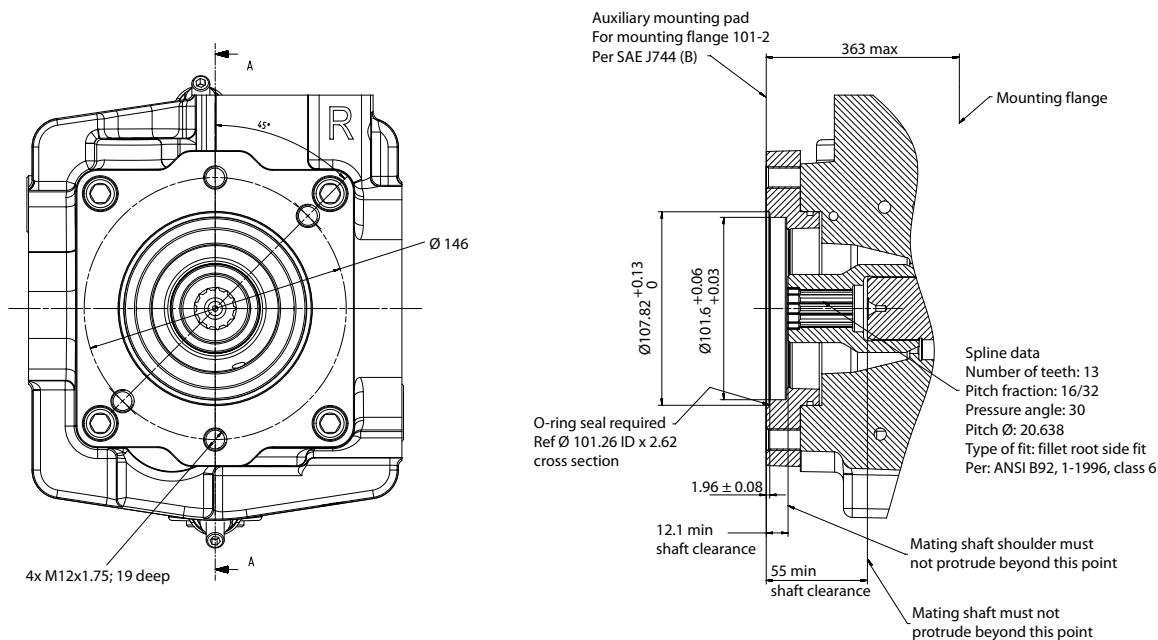

Specifications

Option	Coupling	Max torque
BA	7/8in, 13T, 16/32DP	411 N·m [3637.66 lbf·in]

**Size 130/145: Option C5 (SAE-C, 14 teeth)**

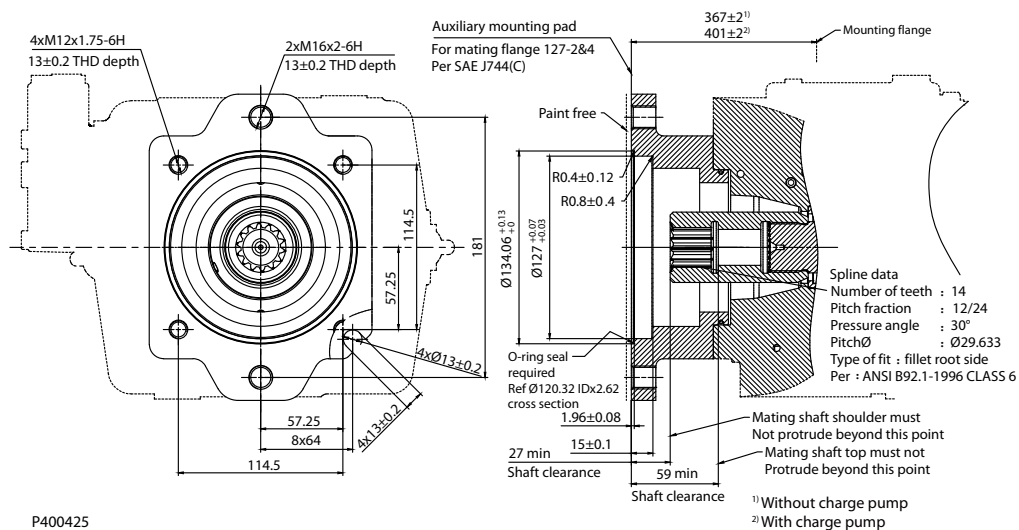

Specifications

Option	Coupling	Max torque
C5	1 ¼ in, 14T 12/24 DP	1164 N·m [10302.27 lbf·in]

Installation Drawings

**Size 130/145: Option D5 (SAE-D, 24 teeth)**

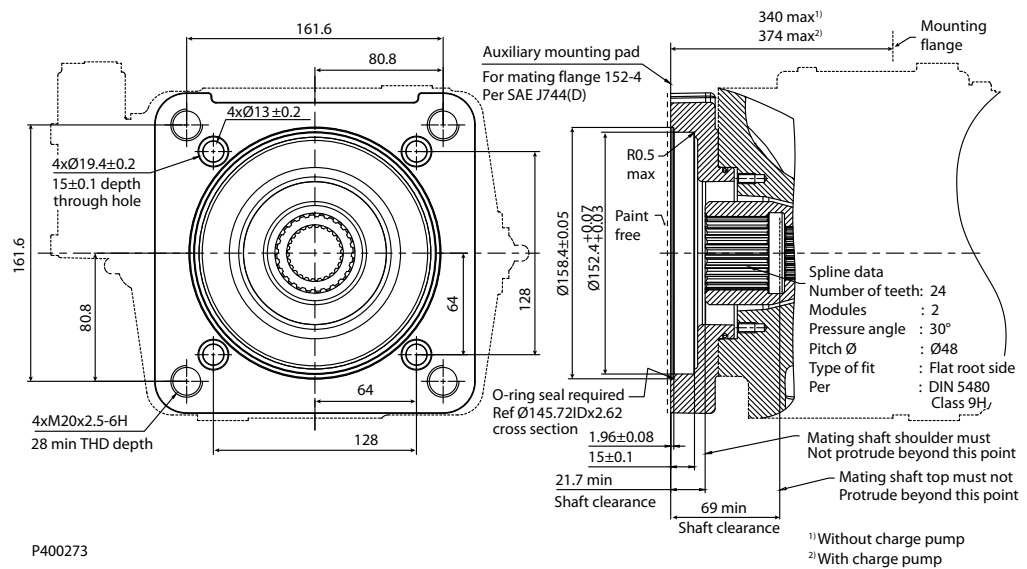

Specifications

Option	Coupling	Max torque
D5	N50 x 2 x 30 x 24 x 9H	1164 N•m [10302.27 lbf•in]

Before finalizing your design, please request a certified drawing.

**Installation Drawings**

**Size 193**

**Dimensions (mm) and port descriptions**

**Size 193: TPE2 w/ Charge Pump**

Control : TPE2

Power Control (T) + Pressure Compensated Control (P) + Electric Displacement Control (E2)

Auxiliary flange : B1

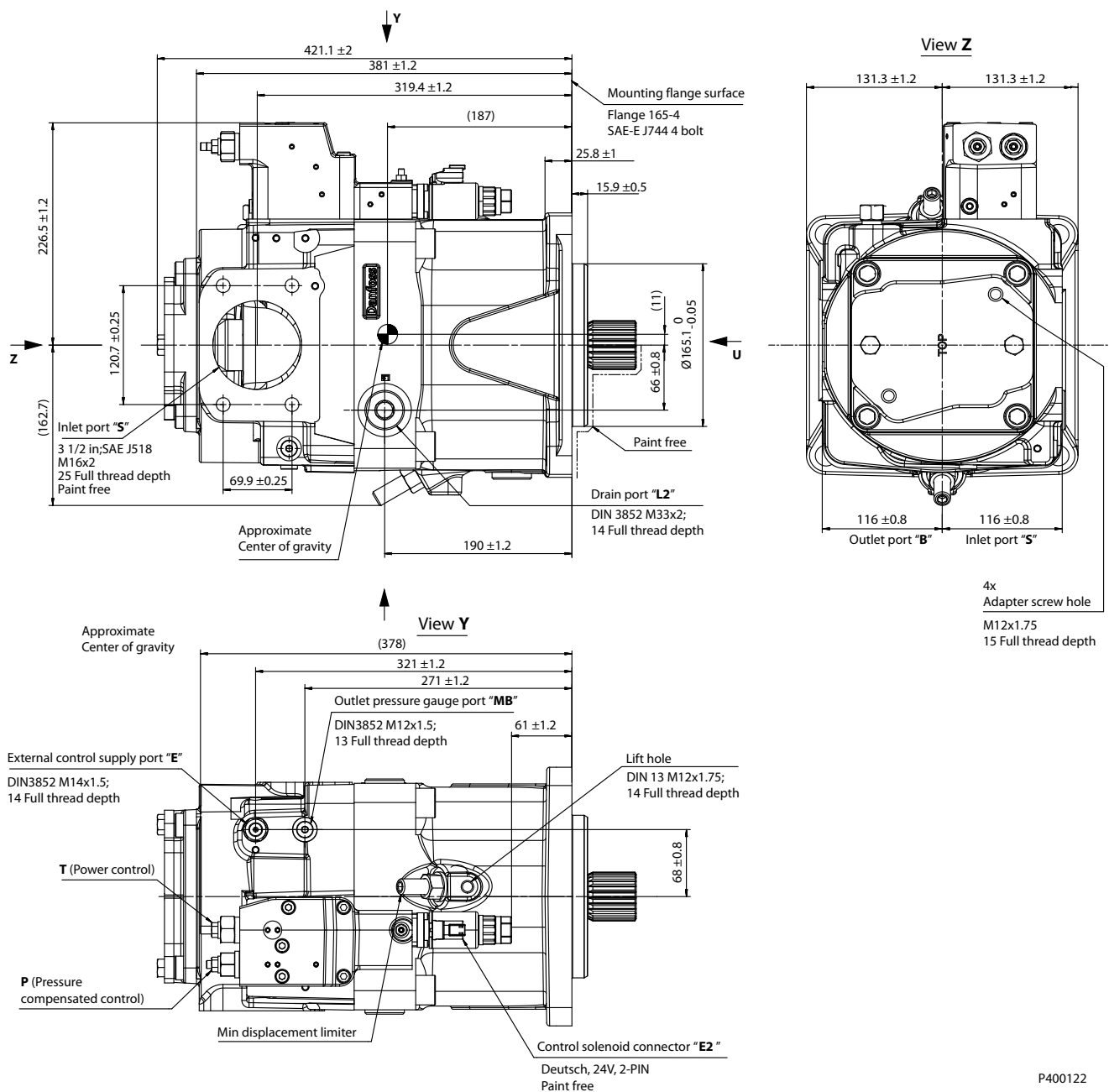

P400122

Before finalizing your design, please request a certified drawing.

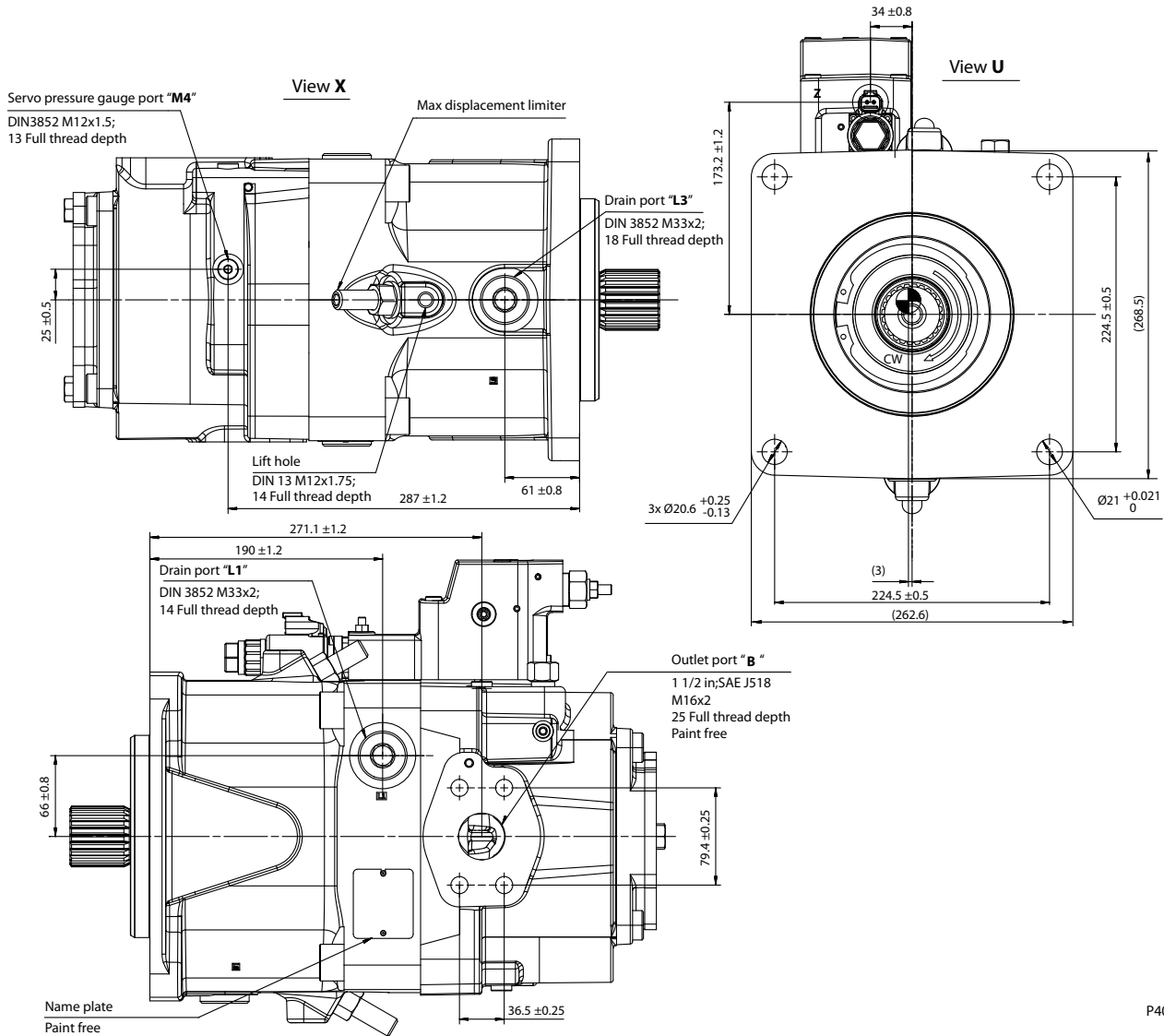
**Installation Drawings**

P400123

Before finalizing your design, please request a certified drawing.

**Port Descriptions**

Ports	Description	Standard	Size <sup>1)</sup>	Max. pressure (bar [psi])	State <sup>2)</sup>
<b>B</b>	Outlet port, Fixing thread	SAE J518, DIN13	1 1/2 in, M16 x 2; 25 deep	400 [5802]	O
<b>S</b>	Suction port, Fixing thread	SAE J518, DIN13	3 1/2 in, M16 x 2; 25 deep	2 [29]	O
<b>L<sub>1</sub>, L<sub>2</sub>, L<sub>3</sub></b>	Drain port	DIN 3852	M33 x 2; 14,14, 18 deep	2 [29]	X <sup>3)</sup>
<b>M<sub>4</sub></b>	Measurement point, servo-piston chamber	DIN 3852	M12 x 1.5; 13 deep	400 [5802]	X
<b>M<sub>B</sub></b>	Measurement point, outlet port	DIN 3852	M12 x 1.5; 13 deep	400 [5802]	X
<b>E</b>	External control port	DIN 3852	M14 x 1.5; 14 deep	200 [2901]	X <sup>4)</sup>

<sup>1)</sup> For required torque, please refer to [DIP tightening torque](#) on page 94

<sup>2)</sup> O = Open, must be connected (closed by plastic plug on delivery) / X = Closed (closed by metal plug on delivery)

<sup>3)</sup> Depending on installation position, one of L<sub>1</sub>, L<sub>2</sub> and L<sub>3</sub> must be connected (please refer to Installation Notes).

<sup>4)</sup> If E port is not used, remove the shuttle valve and lock port by seal plug.

Installation Drawings

**Size 193: TPSN w/ Charge Pump**

**Control : TPSN**

Power Control (T) + Pressure Compensated Control (P) + Load Sensing Control (S)

**Auxiliary flange : NN**

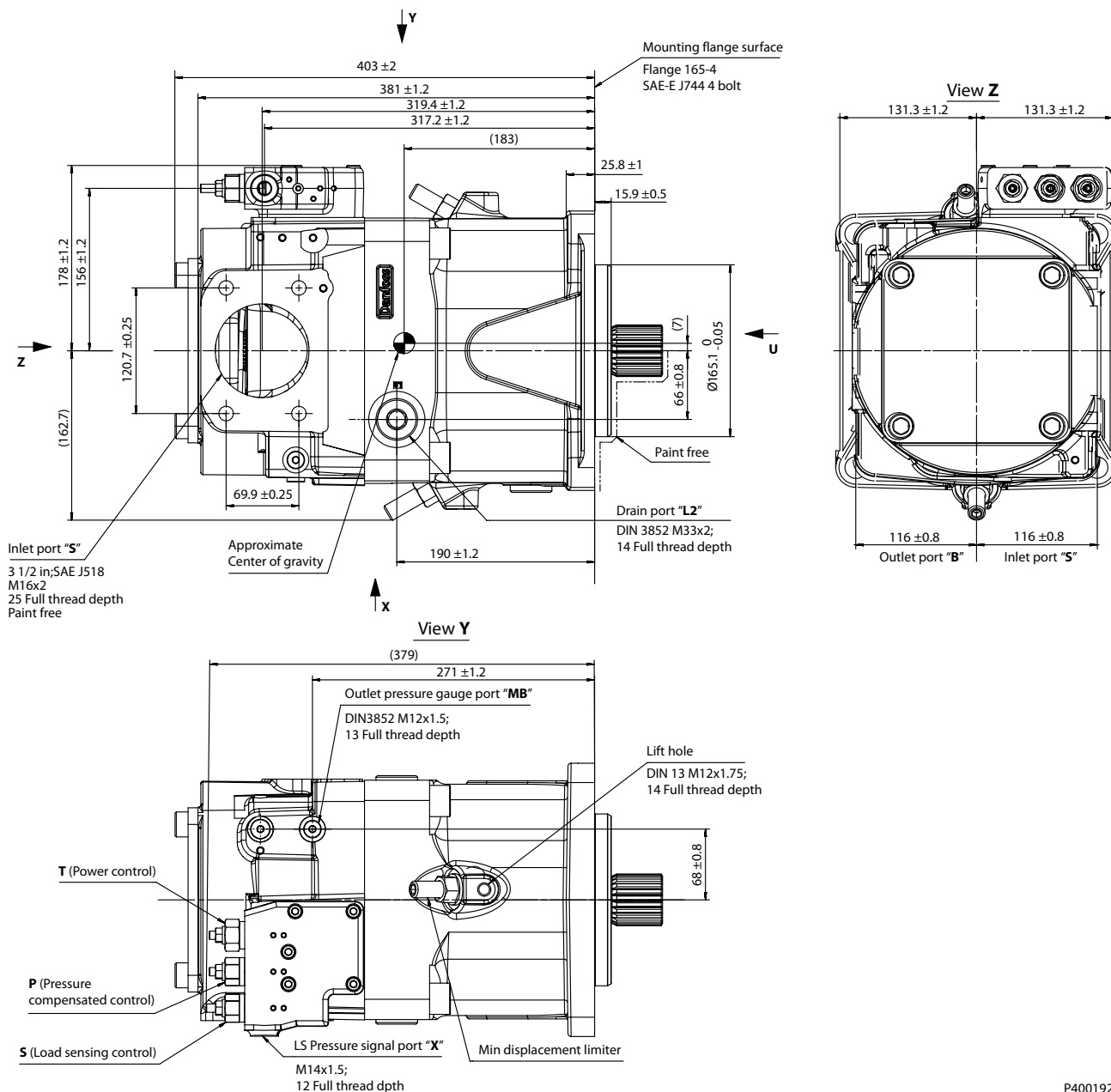

P400192

Before finalizing your design, please request a certified drawing.

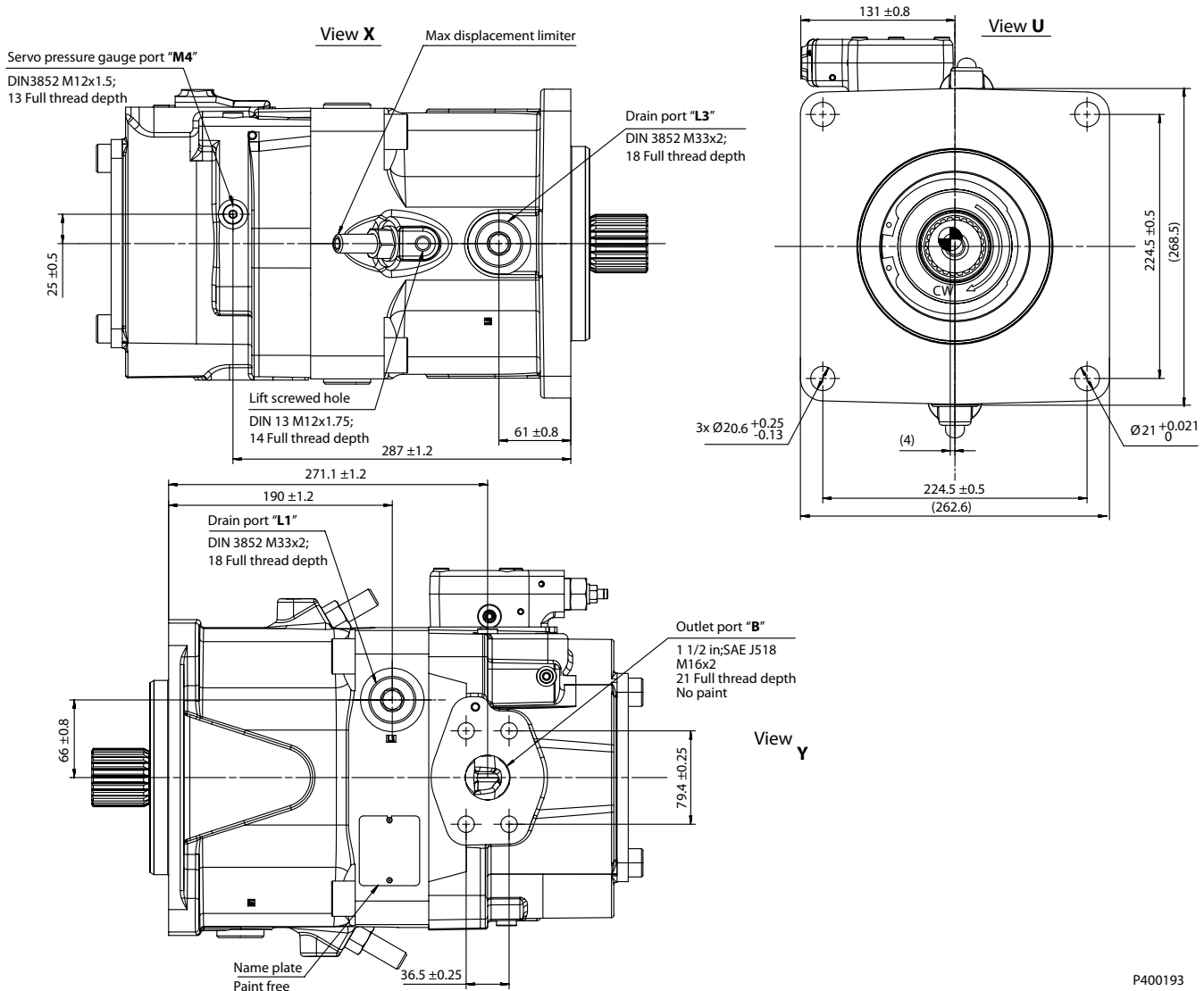
**Installation Drawings**

P400193

Before finalizing your design, please request a certified drawing.

**Port Descriptions**

Ports	Description	Standard	Size <sup>1)</sup>	Max. pressure (bar [psi])	State <sup>2)</sup>
<b>B</b>	Outlet port, Fixing thread	SAE J518, DIN13	1 1/2 in, M16 x 2; 25 deep	400 [5802]	O
<b>S</b>	Suction port, Fixing thread	SAE J518, DIN13	3 1/2 in, M16 x 2; 25 deep	2 [29]	O
<b>L<sub>1</sub>, L<sub>2</sub>, L<sub>3</sub></b>	Drain port	DIN 3852	M33 x 2; 14, 14, 18 deep	2 [29]	X <sup>3)</sup>
<b>M<sub>4</sub></b>	Measurement point, servo-piston chamber	DIN 3852	M12 x 1.5; 13 deep	400 [5802]	X
<b>M<sub>B</sub></b>	Measurement point, outlet port	DIN 3852	M12 x 1.5; 13 deep	400 [5802]	X
<b>X</b>	LS port	DIN 3852	M14 x 1.5; 12 deep	400 [5802]	O

<sup>1)</sup> For required torque, please refer to [DIP tightening torque](#) on page 94.

<sup>2)</sup> O = Open, must be connected (closed by plastic plug on delivery) / X = Closed (closed by metal plug on delivery).

<sup>3)</sup> Depending on installation position, one of L<sub>1</sub>, L<sub>2</sub> and L<sub>3</sub> must be connected (please refer to Installation Notes).



Installation Drawings

Input shaft

D1P 193 shaft specifications

Code	Description	Maximum Torque Rating	Drawing
T	Splined shaft DIN 5480, W50 x 2 x 30 x 24 x 9g	3100 N·m [27437 lbf·in]	<p><b>Min. active spline length<sup>(2)</sup>: 44 mm [1.73 in]</b></p>
S	Splined shaft SAE J744, 1 3/4 in, 13T, 8/16 DP	1536 N·m [13595 lbf·in]	<p><b>Min. active spline length<sup>(2)</sup>: 55 mm [2.17 in]</b></p>

Installation Drawings

Code	Description	Maximum Torque Rating	Drawing
A	Splined shaft SAE J744, 2 in, 15T, 8/16 DP	2422 N•m [21437 lbf•in]	<p>7.8 ± 0.8</p> <p>Mating coupling must not protrude beyond this point</p> <p>Paint free</p> <p>Spline data      Number of teeth: 15      Pitch friction : 8/16      Pressure angle : 30°      pitch : Ø 47.625      Type of fit : Fillet root side      Per : ANSI B92.1-1996, Class 5</p> <p>12 ± 2 5.2 ± 0.5</p> <p>Ø40.7±0.1</p> <p>Ø50.8 - 0.127</p> <p>Ø126±0.1</p> <p>36 ± 2 FULL THD 44 ± 1</p> <p>66.0 0.5</p> <p>(87.7)</p> <p>Mounting flange Flange 165-4 Per SAE J744</p> <p>5/8-11 UNC-2B THD Ø17±0.2 Ø23±0.2</p> <p>P400427</p> <p><b>Min. active spline length<sup>(2)</sup>: 66 mm [2.60 in]</b></p>

Installation Drawings

Code	Description	Maximum Torque Rating	Drawing
P	Straight keyed shaft, DIN 6885, AS16x10x100	2195 N·m [19427 lbf·in]	<p>Paint free</p> <p>Mounting flange Flange 165-4 SAE-E SAE J744 4 bolt</p> <p>100 +0.5/0</p> <p>2 +0.2/0</p> <p>Key, AS16x10x100</p> <p>M5 x 0.8</p> <p>Ø 60 -0.03</p> <p>R1 ± 0.1</p> <p>6 ± 0.5</p> <p>15 ± 2</p> <p>42 ± 2 Full THD 55 ± 1</p> <p>M20 x 2.5 THD</p> <p>Ø 21 ± 0.2</p> <p>Ø 28 ± 0.2</p> <p>Ø 55 - 0.06 (59)</p> <p>Ø 126 ± 0.1</p> <p>105 +0.1/0</p> <p>112.7 ± 0.5</p> <p>Mating coupling must not protrude beyond this point</p>
K	SAE J744 (D/E) 3in straight keyed shaft, 0.4375x3.000 in	1787 N·m [15816 lbf·in]	<p>Paint free</p> <p>Mounting flange Flange 165-4 SAE-E J744 4 bolt</p> <p>77.7 ± 0.8</p> <p>(1.5)</p> <p>Key-SQ, 0.4175 x 3.000, hard</p> <p>Ø 60 -0.03</p> <p>R1.5 ± 0.1</p> <p>4.4 ± 0.5</p> <p>9.5 ± 2</p> <p>28 ± 2 Full THD 36 ± 1</p> <p>7/16 - 14UNC-2B THD</p> <p>Ø 13 ± 0.2</p> <p>Ø 18.1 ± 0.2</p> <p>Ø 44.45 -0.05 (49.3)</p> <p>Ø 126 ± 0.1</p> <p>92 +0.1/0</p> <p>100 ± 0.5</p> <p>Mating coupling must not protrude beyond this point</p>

- 1) Center bore according to DIN 332 (thread according to DIN 13)
- 2) Minimum active spline length for the specified torque ratings

**Installation Drawings**

**Aux mounting flange**

**Size 193: Option NN (No Coupling)**

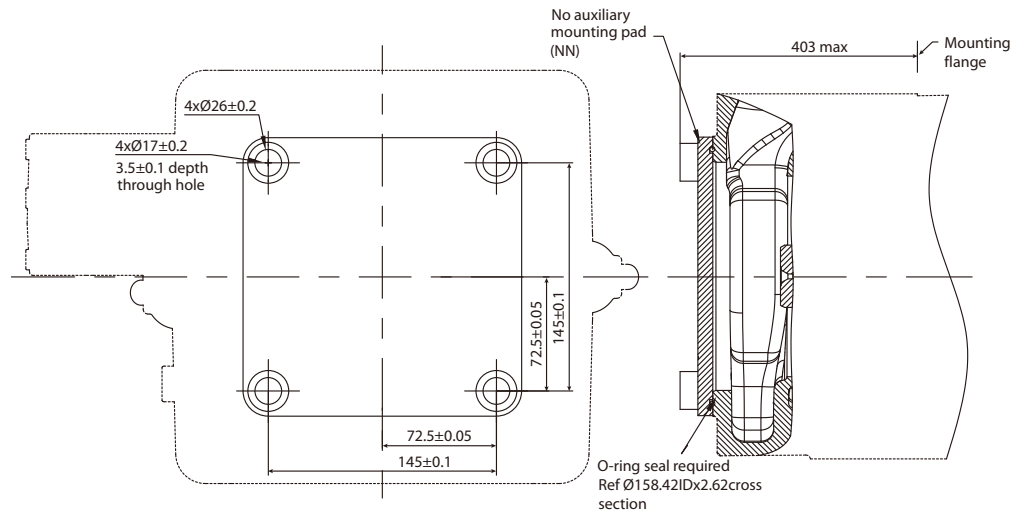

P400274

**Specifications**

Option	Coupling
NN	No coupling

**Size 193: Option A1 (SAE-A, 9 teeth)**

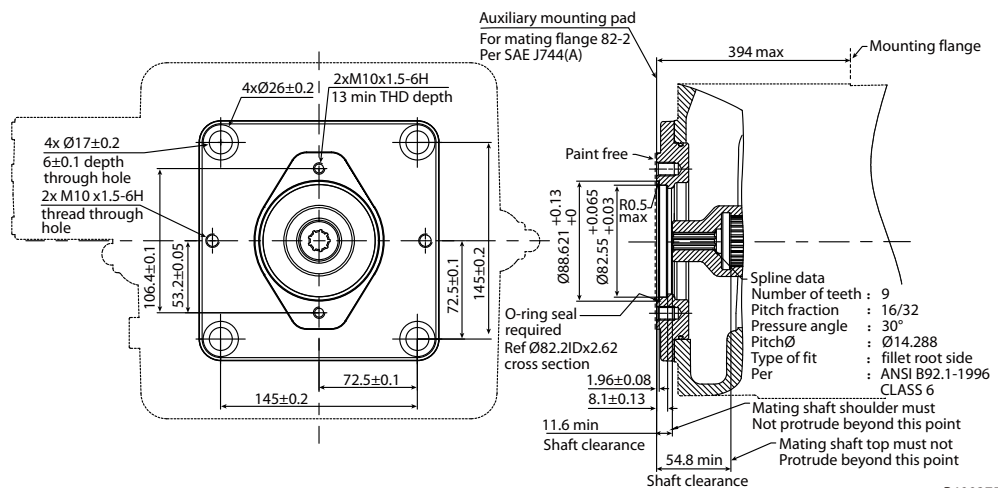

P400275

**Specifications**

Option	Coupling	Max torque
A1	5/8 in, 9T, 16/32 DP	205 N·m [1814.40 lbf·in]

**Installation Drawings**

**Size 193: Option A3 (SAE-A, 13 teeth)**

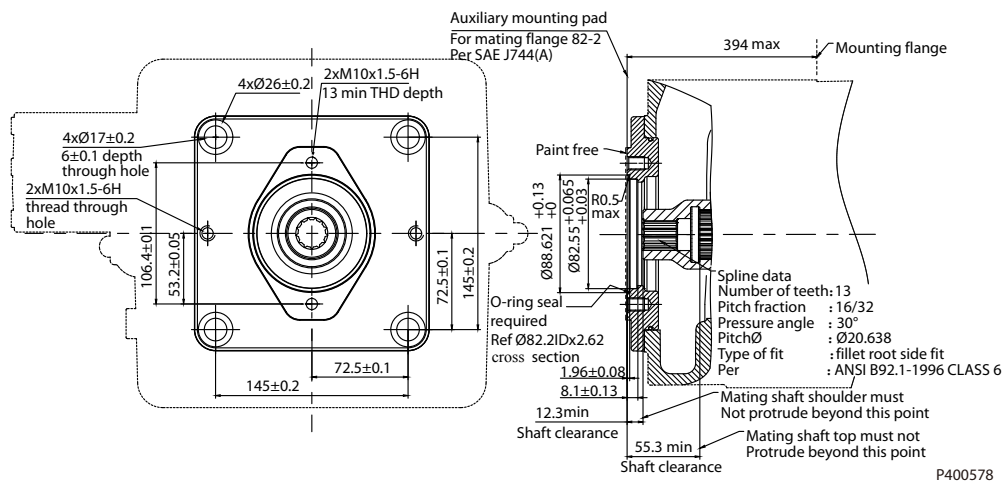

P400578

**Specifications**

Option	Coupling	Max torque
A3	7/8 in, 13T, 16/32 DP	619 N·m [5478.61 lbf·in]

**Size 193: Option B1 (SAE-B, 13 teeth)**

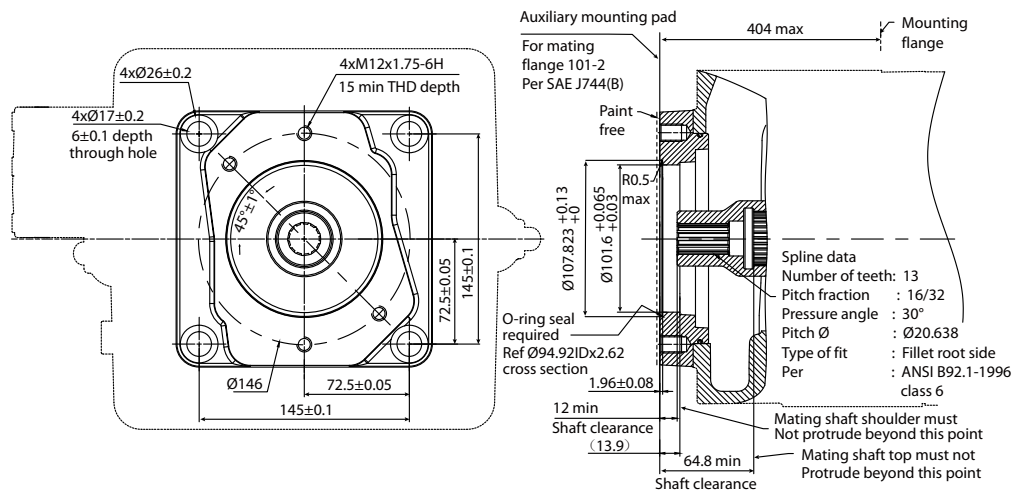

P400276

**Specifications**

Option	Coupling	Max torque
B1	7/8 in, 13T, 16/32 DP	411 N·m [3637.66 lbf·in]

Installation Drawings

**Size 193: Option B2 (SAE-B, 15 teeth)**

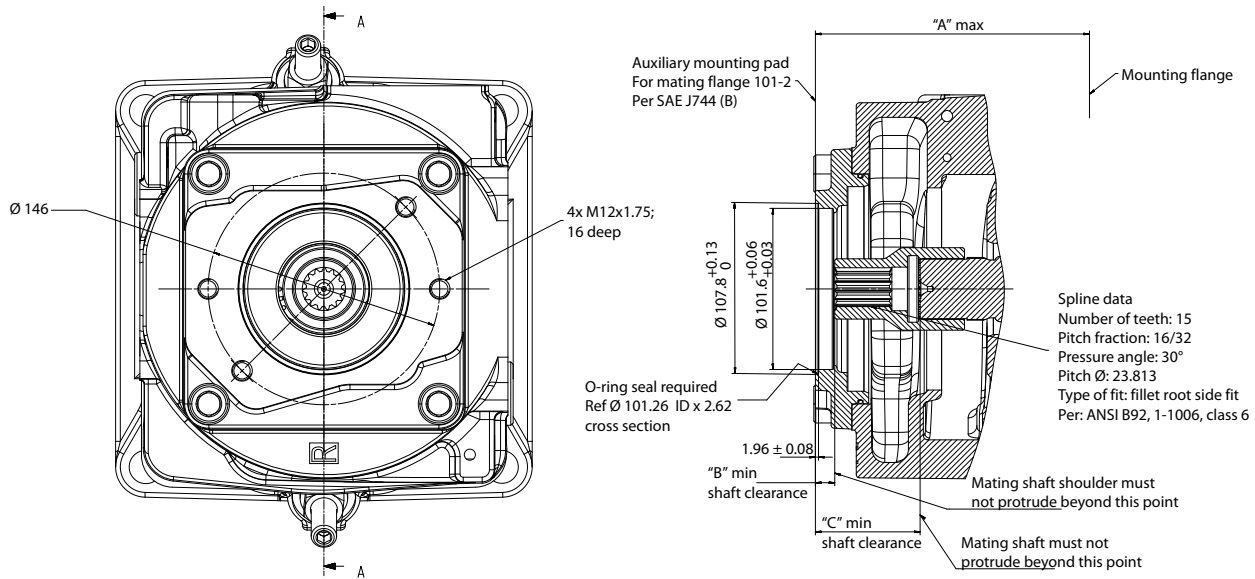

Legend

Dimension	Y2	N3
A	404	369.8
B	12.2	12.3
C	65	63.2

Specifications

Option	Coupling	Max torque
B2	1in, 15T, 16/32DP	Pending

**Installation Drawings**

**Size 193: Option BA (SAE-B, 13 teeth)**

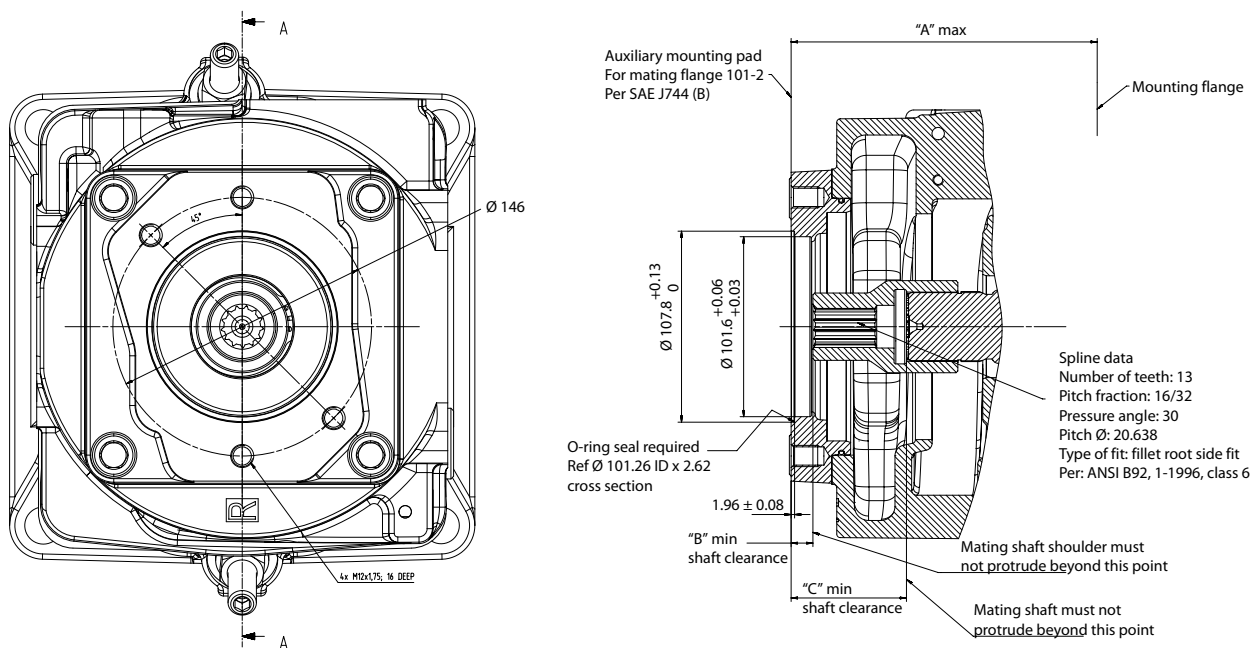

*Legend*

Dimension	Value
A	404
B	12
C	64

*Specifications*

Option	Coupling	Max torque
BA	7/8in, 13T, 16/32DP	411 N·m [3637.66 lbf·in]

Installation Drawings

**Size 193: Option BB (SAE-B, 13 teeth)**

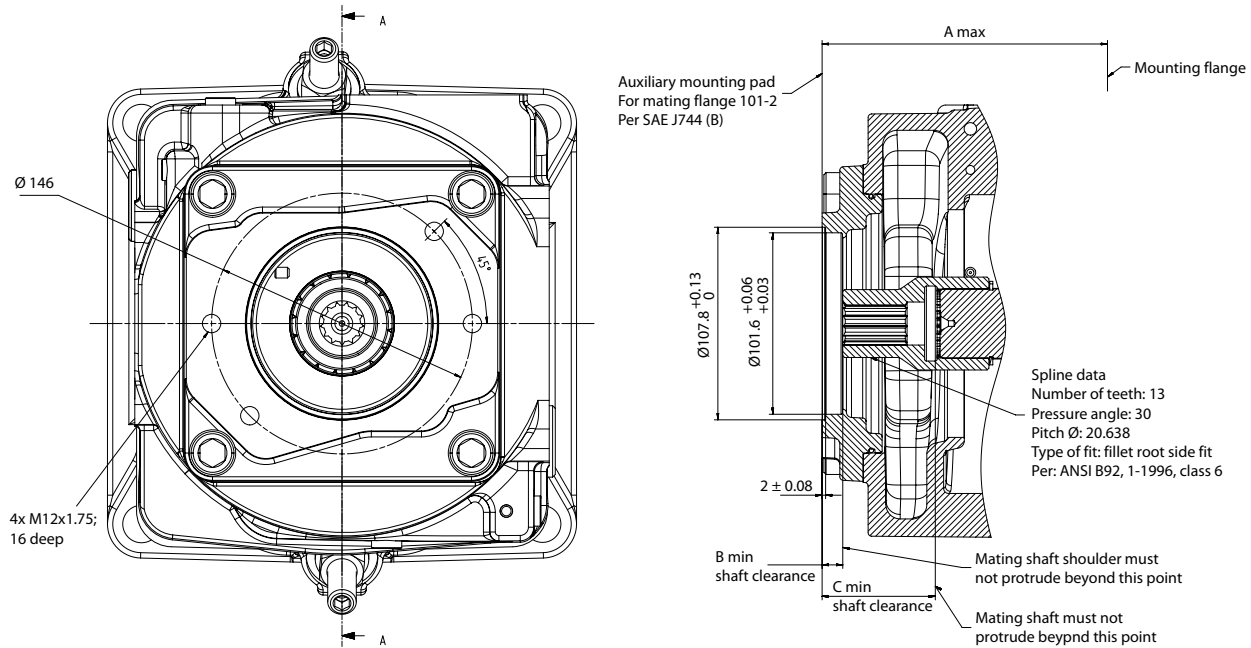

*Legend*

Dimension	Value
A	404
B	11.6
C	63.4

*Specifications*

Option	Coupling	Max torque
BB	7/8in, 13T, 16/32DP	411 N·m [3637.66 lbf·in]



**Installation Drawings**

**Size 193: Option C5 (SAE-C, 14 teeth)**

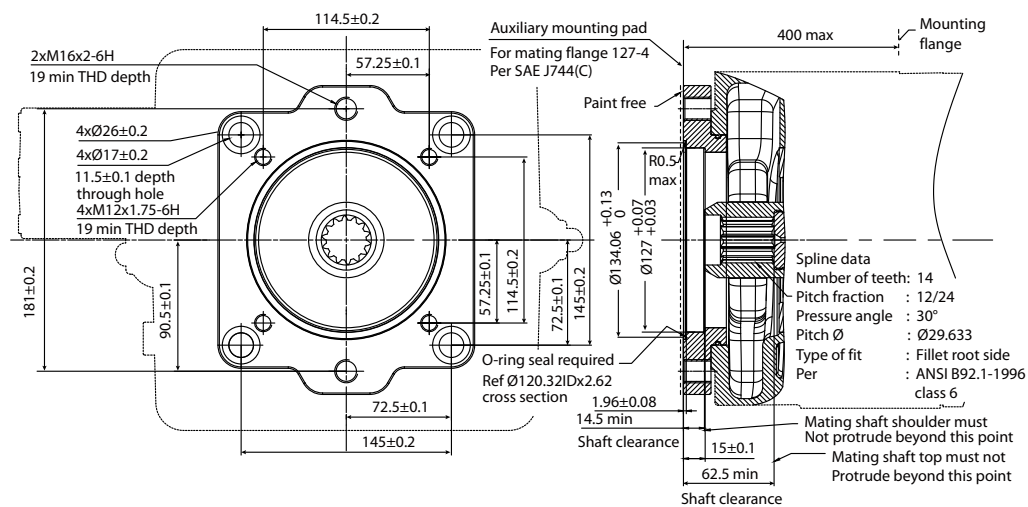

P400277

**Specifications**

Option	Coupling	Max torque
C5	1 1/4 in, 14T, 12/24 DP	1289 N·m [11408.61 lbf·in]

**Size 193: Option C9 (SAE-C, 13 teeth)**

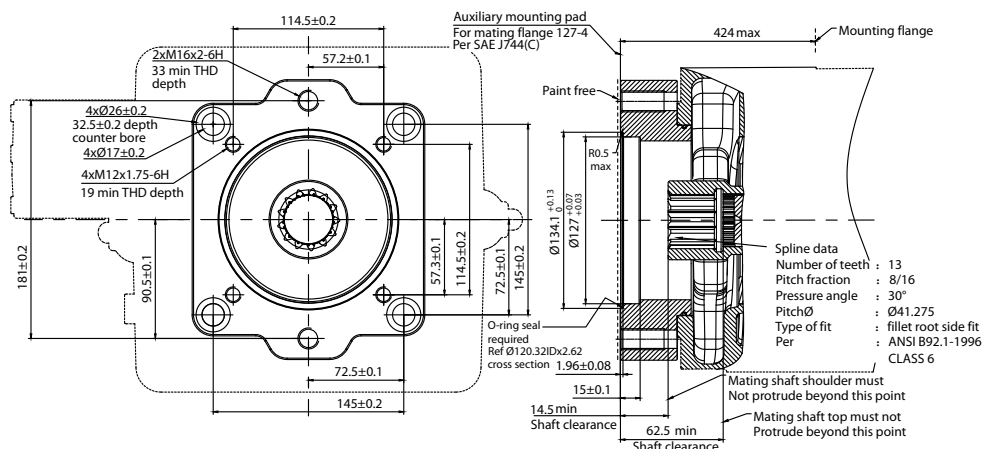

P400579

**Specifications**

Option	Coupling	Max torque
C9	1 3/4 in, 13T, 8/16 DP	1790 N·m [15842.83 lbf·in]

**Installation Drawings**

**Size 193: Option D2 (SAE-D, 13 teeth)**

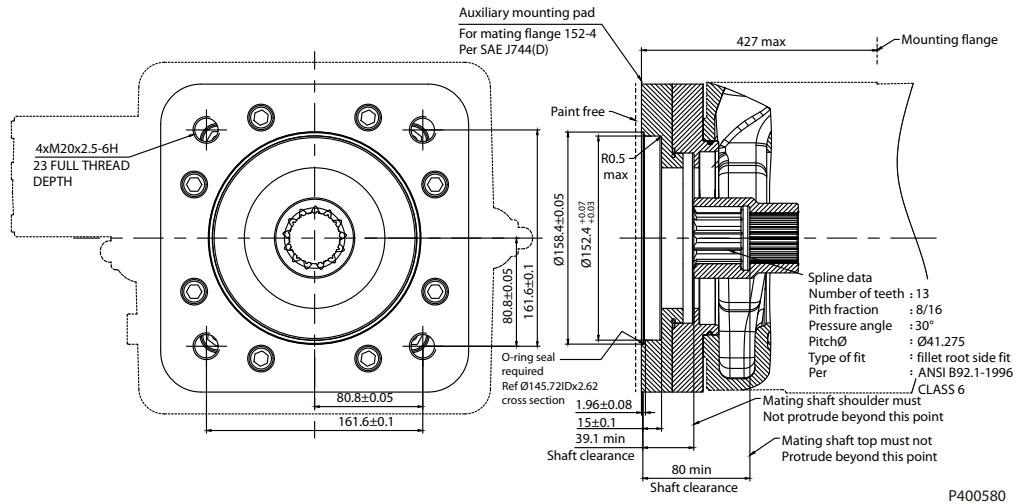

**Specifications**

Option	Coupling	Max torque
D2	1 3/4 in, 13T, 8/16 DP	1630 N·m [14426.72 lbf·in]

**Size 193: Option D5 (SAE-D, 24 teeth)**

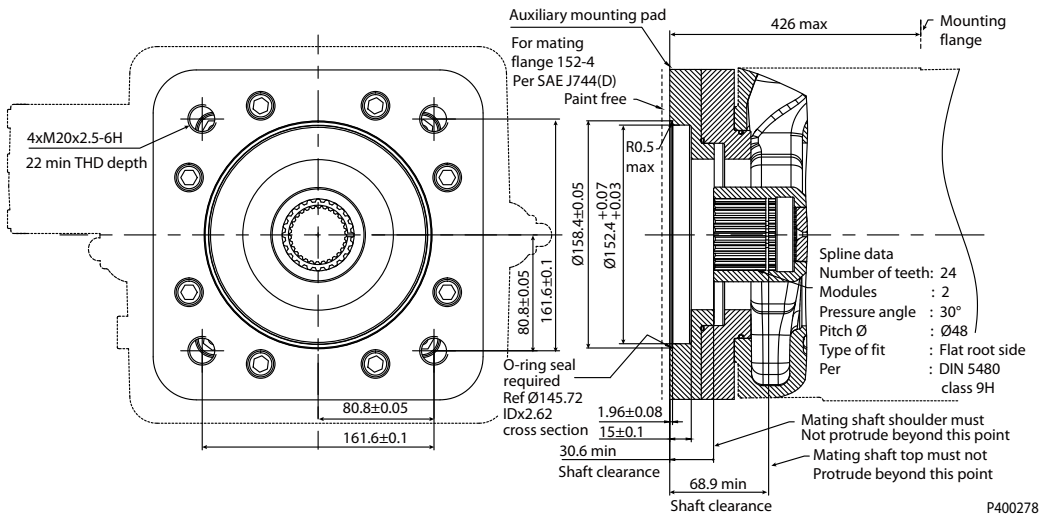

**Specifications**

Option	Coupling	Max torque
D5	N50 x 2 x 30 x 24 x 9H	1790 N·m [15842.83 lbf·in]

**Installation Drawings**

**Size 193: Option E2 (SAE-E, 24 teeth)**

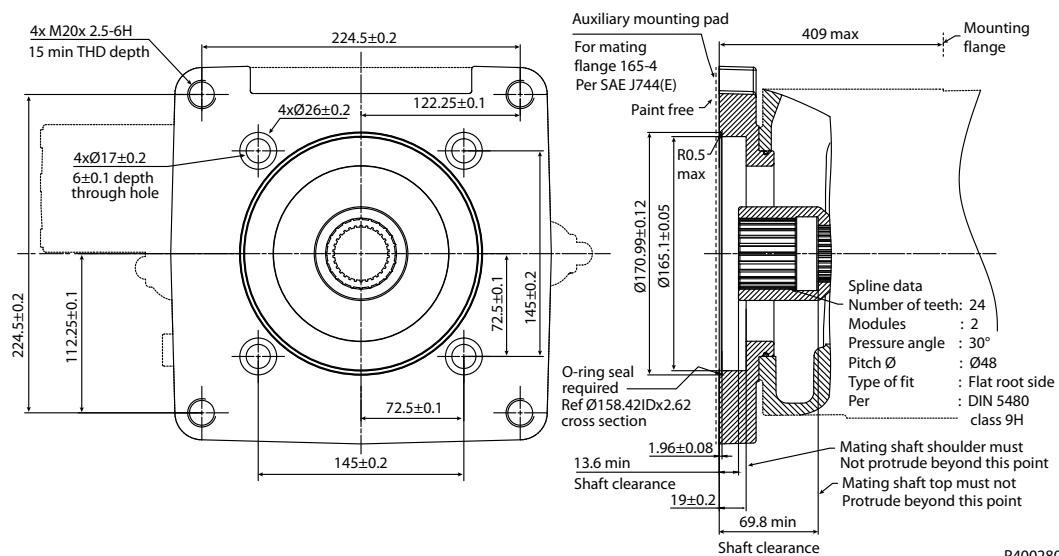

**Specifications**

Option	Coupling	Max torque
E2	N50 x 2 x 30 x 24 x 9H	1790 N·m [15842.83 lbf·in]

Before finalizing your design, please request a certified drawing.

Installation Drawings

Size 260

Dimensions (mm) and port descriptions

Size 260: TPE2 w/ Charge Pump

Control : TPE2

Power Control (T) + Pressure Compensated Control (P) + Electric Displacement Control (E2)

Auxiliary flange : B1

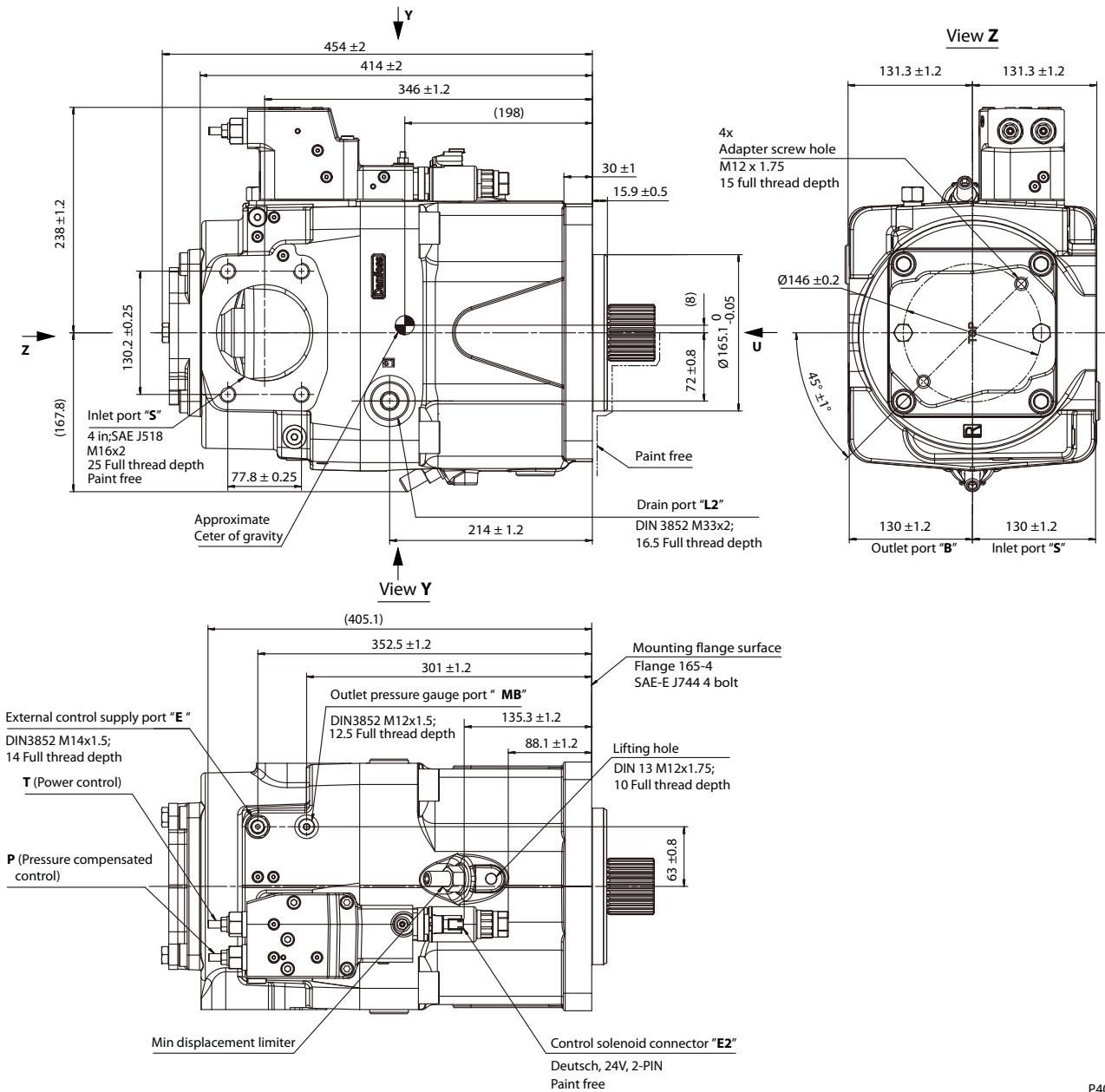

P400410

Before finalizing your design, please request a certified drawing.

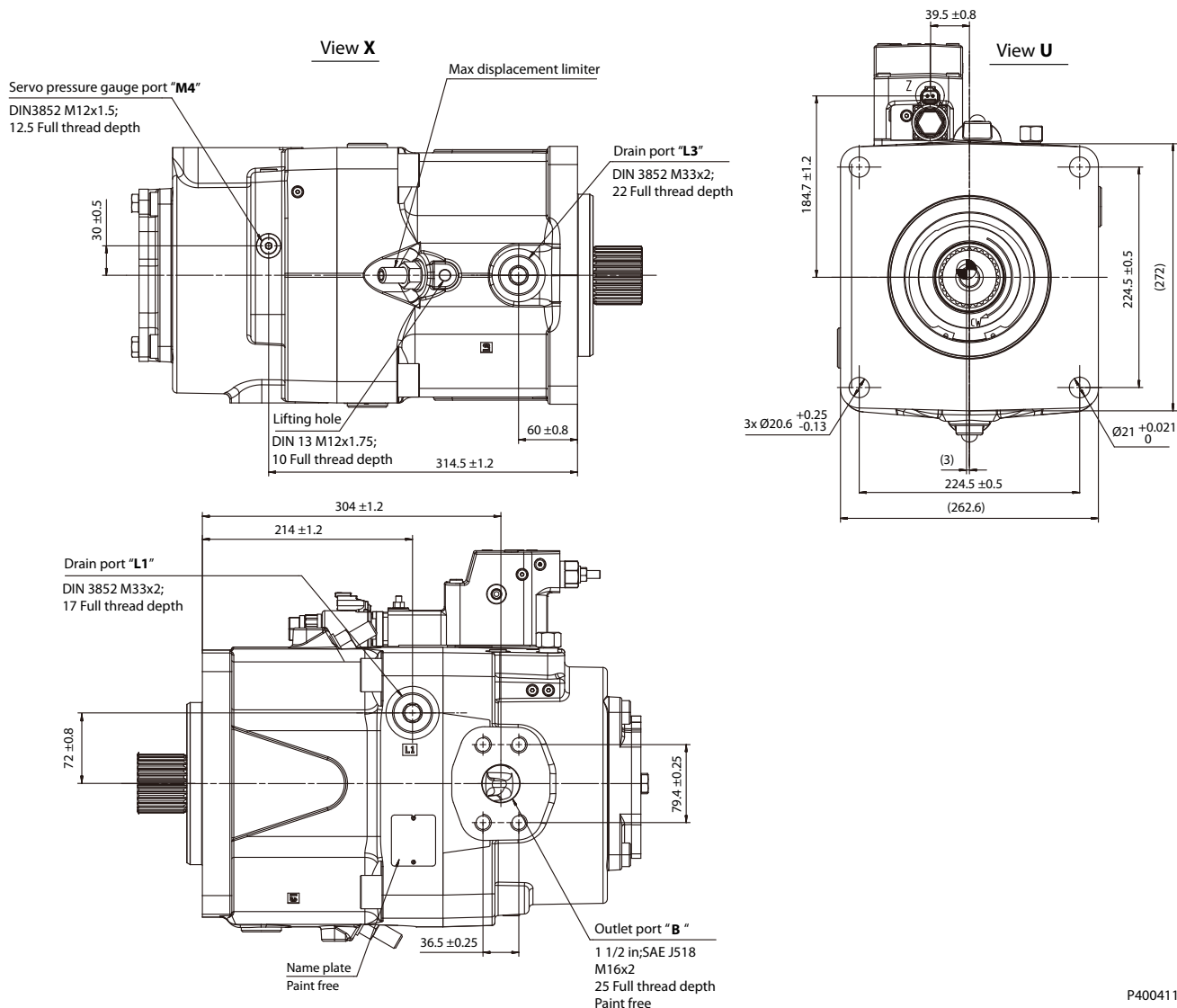
**Installation Drawings**

P400411

Before finalizing your design, please request a certified drawing.

**Port Descriptions**

Ports	Description	Standard	Size <sup>1)</sup>	Max. pressure (bar [psi])	State <sup>2)</sup>
<b>B</b>	Outlet port, Fixing thread	SAE J518, DIN13	1 1/2 in, M16 x 2; 25 deep	400 [5802]	O
<b>S</b>	Suction port, Fixing thread	SAE J518, DIN13	4 in, M16 x 2; 25 deep	2 [29]	O
<b>L<sub>1</sub>, L<sub>2</sub>, L<sub>3</sub></b>	Drain port	DIN 3852	M33 x 2; 17, 16.5, 22 deep	2 [29]	X <sup>3)</sup>
<b>M<sub>4</sub></b>	Measurement point, servo-piston chamber	DIN 3852	M12 x 1.5; 12.5 deep	400 [5802]	X
<b>M<sub>B</sub></b>	Measurement point, outlet port	DIN 3852	M12 x 1.5; 12.5 deep	400 [5802]	X
<b>E</b>	External control port	DIN 3852	M14 x 1.5; 14 deep	200 [2901]	X <sup>4)</sup>

<sup>1)</sup> For required torque, please refer to *DIP tightening torque* on page 94

<sup>2)</sup> O = Open, must be connected (closed by plastic plug on delivery) / X = Closed (closed by metal plug on delivery)

<sup>3)</sup> Depending on installation position, one of L<sub>1</sub>, L<sub>2</sub> and L<sub>3</sub> must be connected (please refer to Installation Notes).

<sup>4)</sup> If E port is not used, remove the shuttle valve and lock port by seal plug.

**Installation Drawings**

**Size 260: TPSN w/ Charge Pump**

**Control : TPSN**

Power Control (T) + Pressure Compensated Control (P) + Load Sensing Control (S)

**Auxiliary flange : NN**

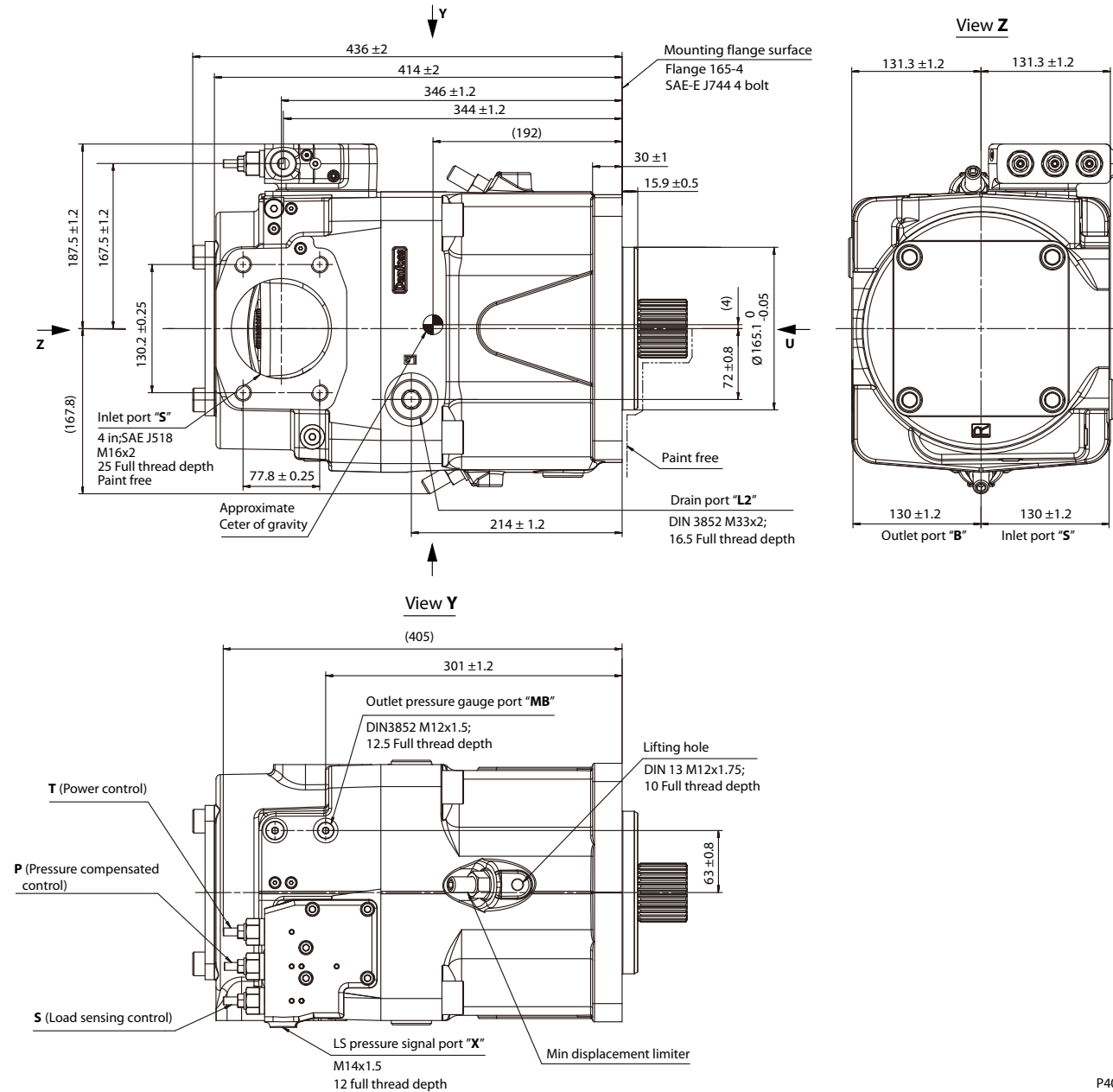

P400412

Before finalizing your design, please request a certified drawing.

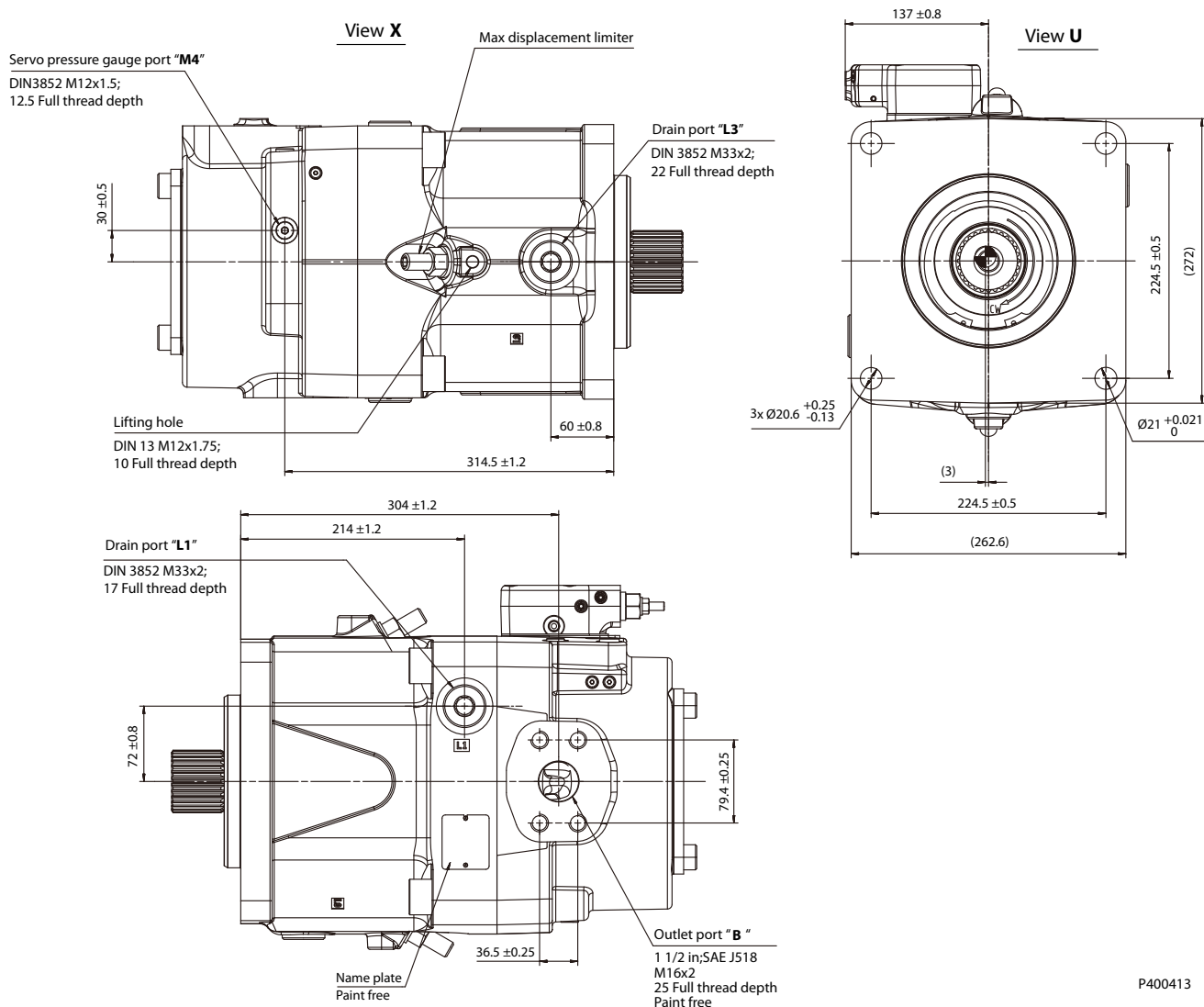
**Installation Drawings**

P400413

Before finalizing your design, please request a certified drawing.

**Port Descriptions**

Ports	Description	Standard	Size <sup>1)</sup>	Max. pressure (bar [psi])	State <sup>2)</sup>
<b>B</b>	Outlet port, Fixing thread	SAE J518, DIN13	1 1/2 in, M16 x 2; 25 deep	400 [5802]	O
<b>S</b>	Suction port, Fixing thread	SAE J518, DIN13	4 in, M16 x 2; 25 deep	2 [29]	O
<b>L<sub>1</sub>, L<sub>2</sub>, L<sub>3</sub></b>	Drain port	DIN 3852	M33 x 2; 17, 16.5, 22 deep	2 [29]	X <sup>3)</sup>
<b>M<sub>4</sub></b>	Measurement point, servo-piston chamber	DIN 3852	M12 x 1.5; 12.5 deep	400 [5802]	X
<b>M<sub>B</sub></b>	Measurement point, outlet port	DIN 3852	M12 x 1.5; 12.5 deep	400 [5802]	X
<b>X</b>	LS port	DIN 3852	M14 x 1.5; 12 deep	400 [5802]	O

<sup>1)</sup> For required torque, please refer to *D1P tightening torque* on page 94.

<sup>2)</sup> O = Open, must be connected (closed by plastic plug on delivery) / X = Closed (closed by metal plug on delivery).

<sup>3)</sup> Depending on installation position, one of L<sub>1</sub>, L<sub>2</sub> and L<sub>3</sub> must be connected (please refer to Installation Notes).

Installation Drawings

Input shaft

D1P 260 shaft specifications

Code	Description	Maximum Torque Rating	Drawing
T	Splined shaft DIN 5480, W60 x 2 x 30 x 28 x 9g	5432 N·m [48077 lbf·in]	<p><b>Min. active spline length<sup>(2)</sup>: 47 mm [1.85 in]</b></p>
S	Splined shaft SAE J744, 1 3/4 in. 13T, 8/16 DP	1535 N·m [13586 lbf·in]	<p><b>Min. active spline length<sup>(2)</sup>: 55 mm [2.17 in]</b></p>



Installation Drawings

Code	Description	Maximum Torque Rating	Drawing
A	Splined shaft SAE J744, 2 1/4 in. 17T, 8/16 DP	3621 N·m [32049 lbf·in]	<p><b>Min. active spline length<sup>(2)</sup>: 66 mm [2.60 in]</b></p>

Installation Drawings

Code	Description	Maximum Torque Rating	Drawing
P	Straight keyed shaft, DIN 6885, AS18x11x100	2571 N•m [22755 lbf•in]	
K	SAE J744 (D/E) Ø1.75in straight keyed shaft, 0.4375 x 3.000in key	1787 N•m [15816 lbf•in]	

- 1) Center bore according to DIN 332 (thread according to DIN 13)
- 2) Minimum active spline length for the specified torque ratings

## Installation Drawings

### Aux mounting flange

#### Size 260: Option A1 (SAE-A, 9 teeth)

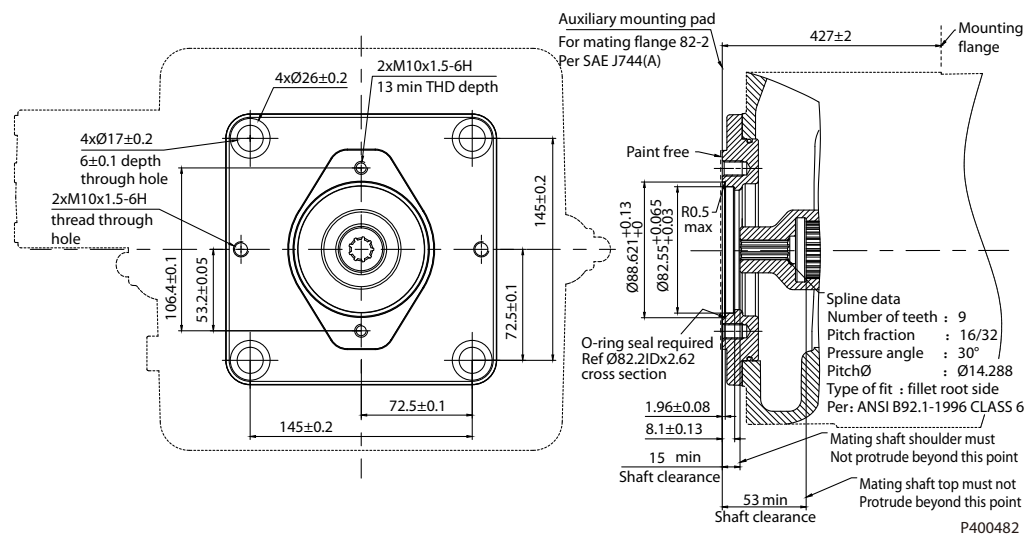

### Specifications

Option	Coupling	Max torque
A1	5/8 in, 9T, 16/32 DP	205 N·m [1814.40 lbf·in]

#### Size 260: Option A3 (SAE-A, 13 teeth)

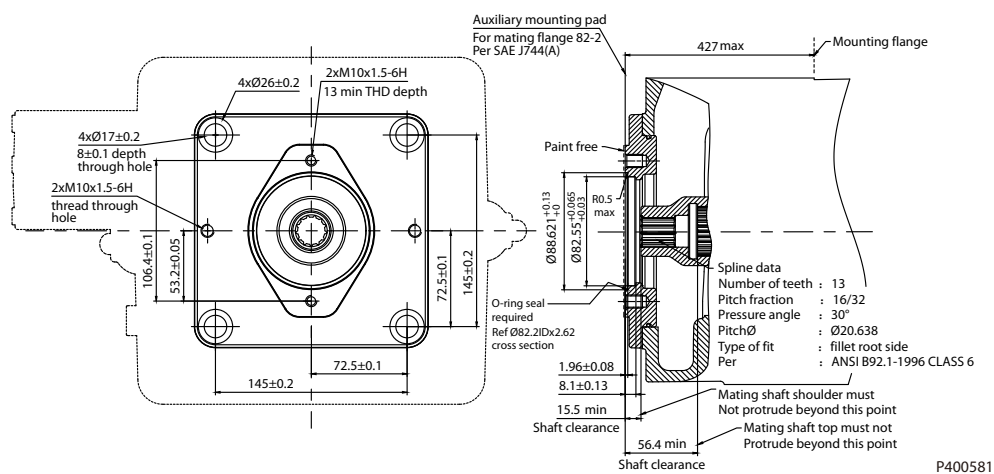

### Specifications

Option	Coupling	Max torque
A3	7/8 in, 13T, 16/32 DP	619 N·m [5478.61 lbf·in]

Installation Drawings

**Size 260: Option B1 (SAE-B, 13 teeth)**

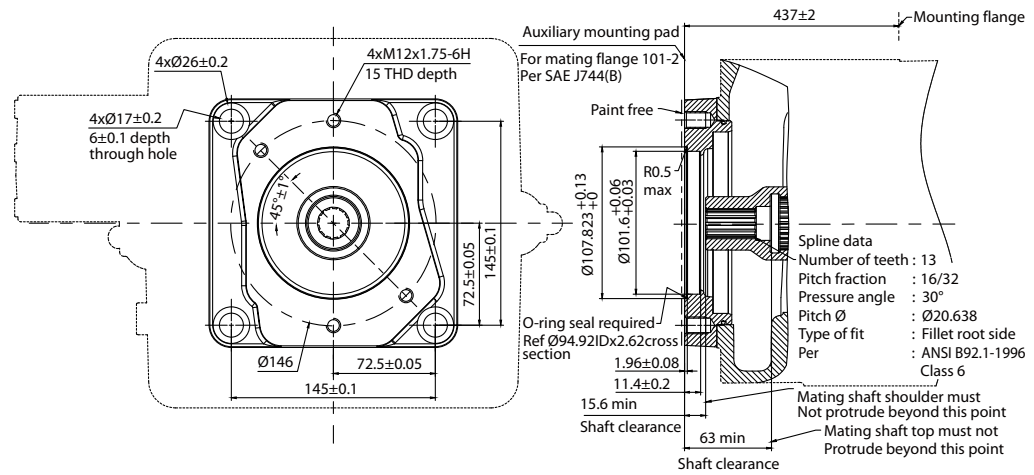

P400415

Specifications

Option	Coupling	Max torque
B1	7/8 in, 13T, 16/32 DP	411 N·m [3637.66 lbf·in]

**Size 260: Option B2 (SAE-B, 15 teeth)**

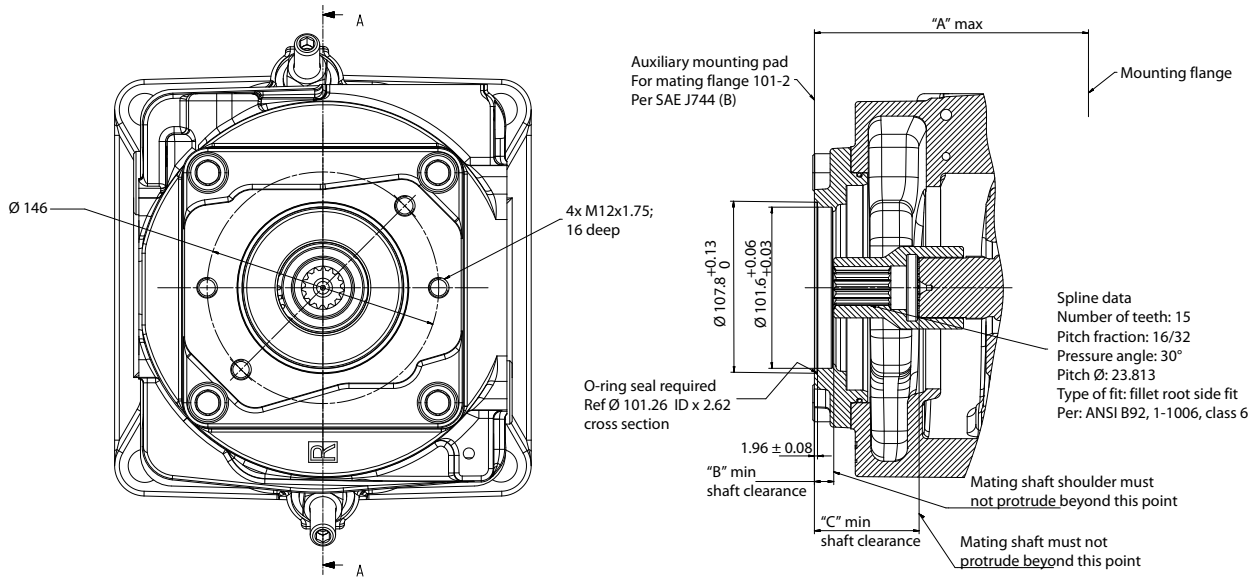

Legend

Dimension	Y3
A	437
B	15.4
C	63

**Installation Drawings**
*Specifications*

Option	Coupling	Max torque
B2	1in, 15T, 16/32DP	Pending

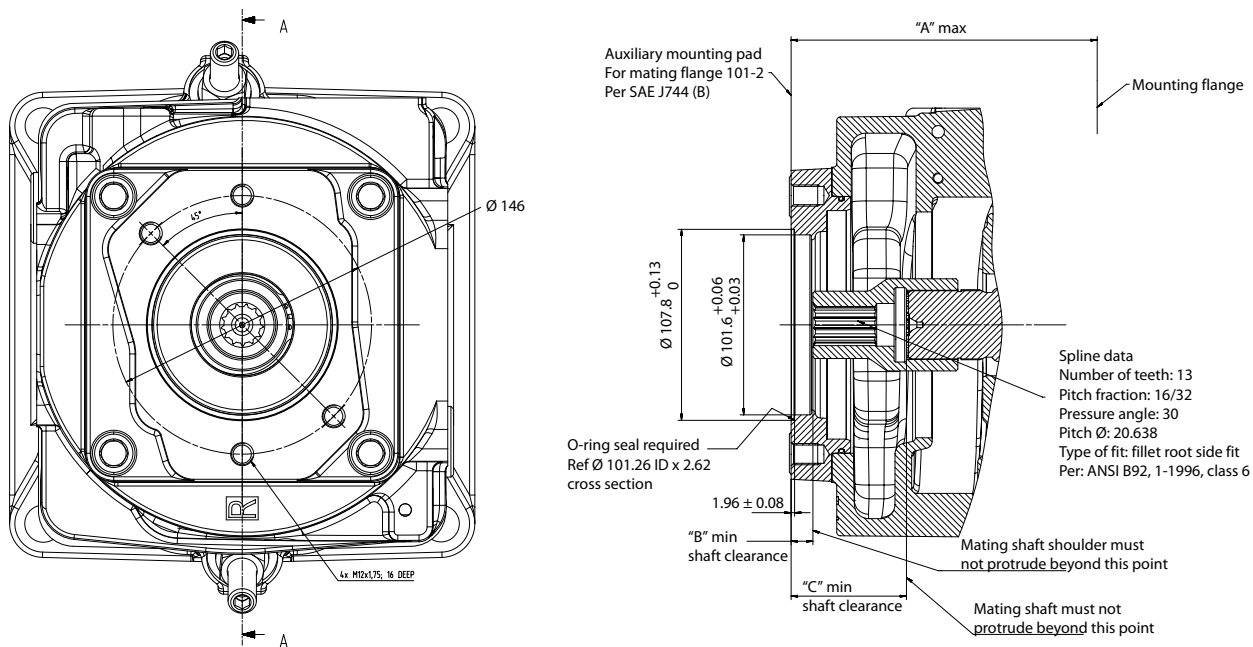
**Size 260: Option BA (SAE-B, 13 teeth)**

*Legend*

Dimension	Value
A	437
B	15.4
C	63

*Specifications*

Option	Coupling	Max torque
BA	7/8in, 13T, 16/32DP	411 N·m [3637.66 lbf·in]

Installation Drawings

**Size 260: Option BB (SAE-B, 13 teeth)**

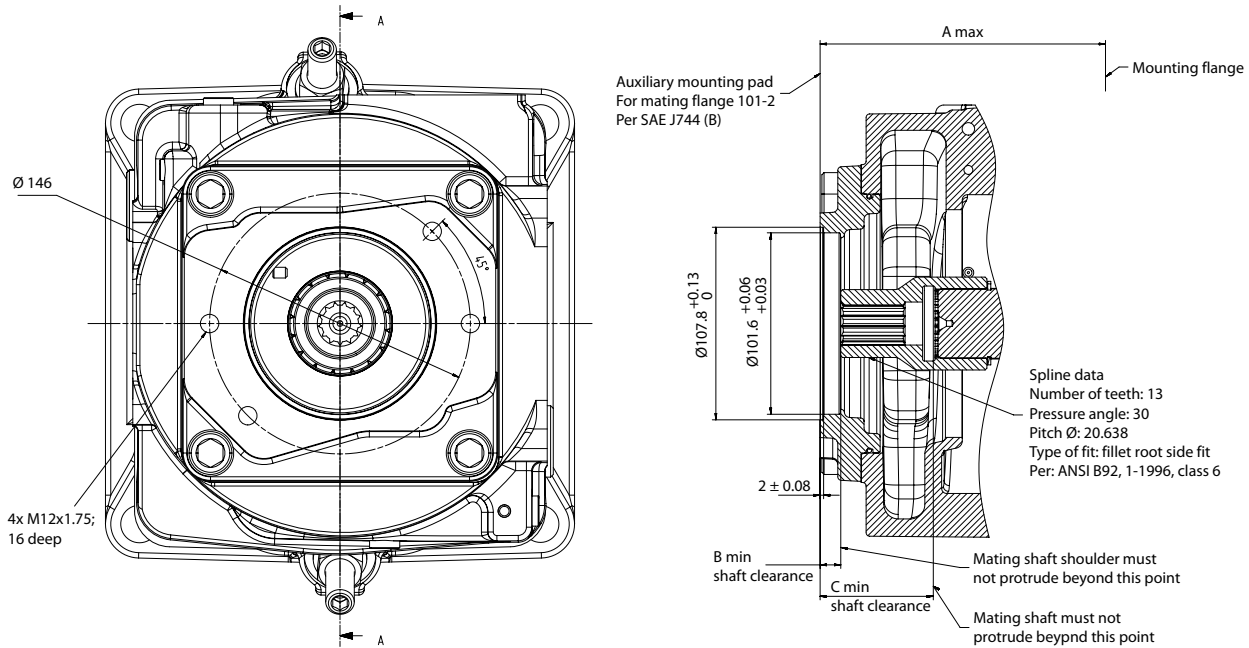

Legend

Dimension	Value
A	437
B	15.4
C	62.25

Specifications

Option	Coupling	Max torque
BB	7/8in, 13T, 16/32DP	411 N·m [3637.66 lbf·in]

Installation Drawings

**Size 260: Option C5 (SAE-C, 14 teeth)**

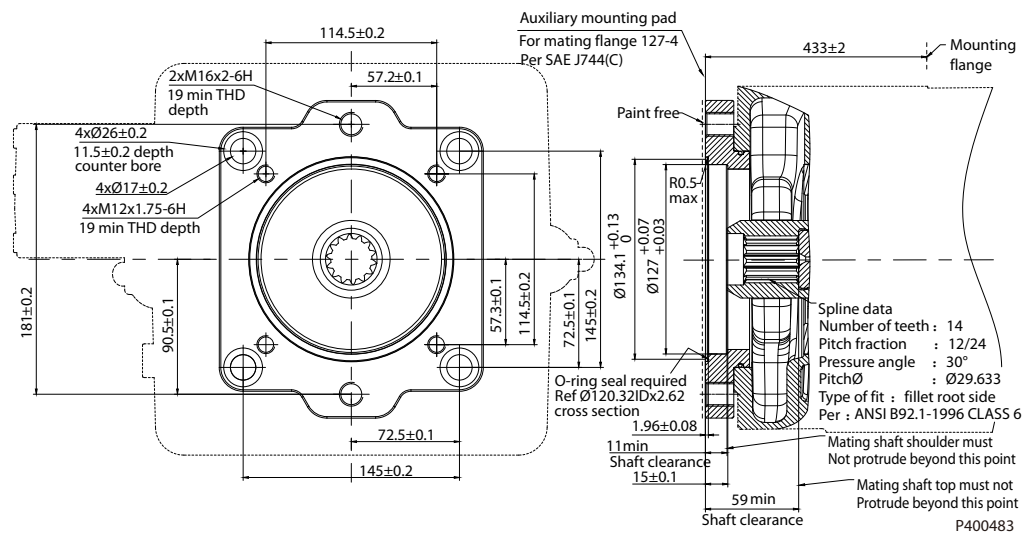

Specifications

Option	Coupling	Max torque
C5	1 1/4 in, 14T, 12/24 DP	1638 N·m [14497.52 lbf·in]

Installation Drawings

**Size 260: Option C9 (SAE-C, 13 teeth)**

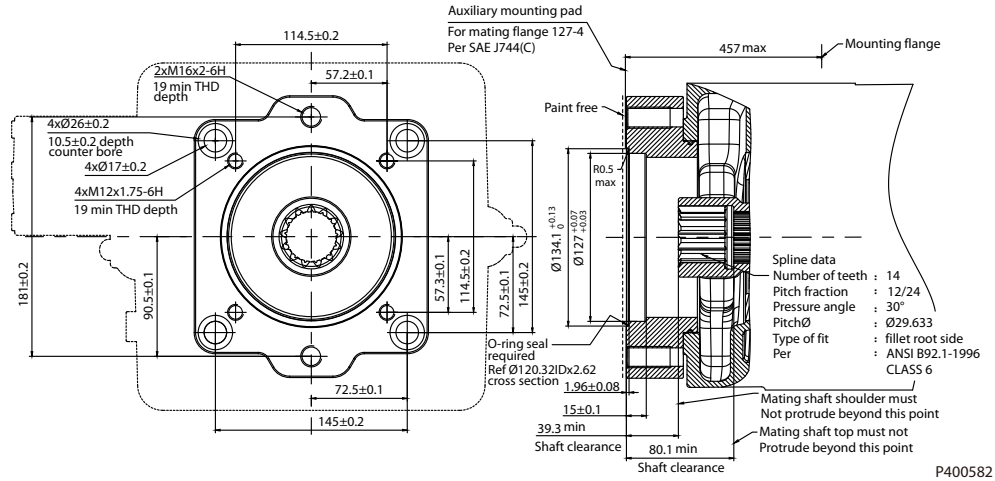

Specifications

Option	Coupling	Max torque
C9	1 3/4 in, 13T, 8/16 DP	1891 N·m [16736.76 lbf·in]

**Size 260: Option D2 (SAE-D, 13 teeth)**

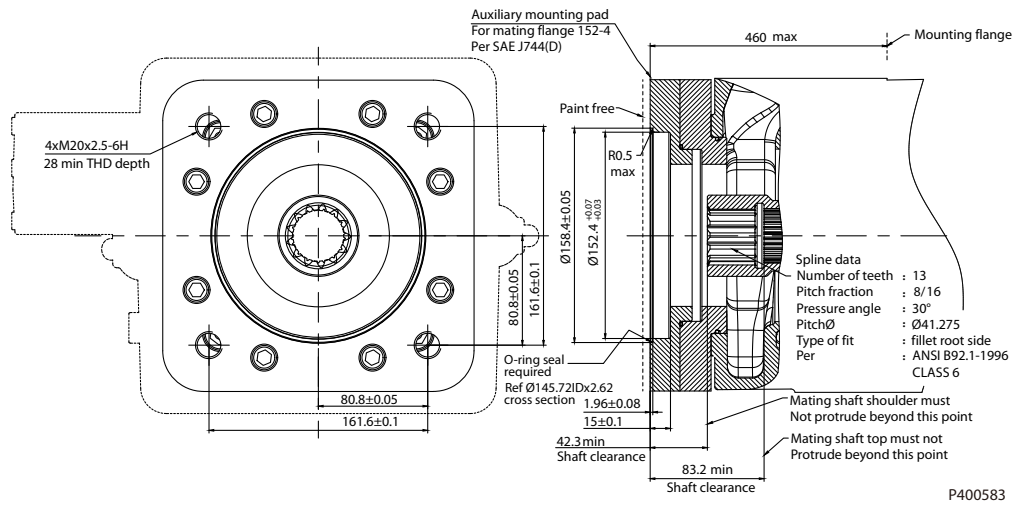

Specifications

Option	Coupling	Max torque
D2	1 3/4 in, 13T, 8/16 DP	1819 N·m [16099.50 lbf·in]



Installation Drawings

**Size 260: Option D5 (SAE-D, 24 teeth)**

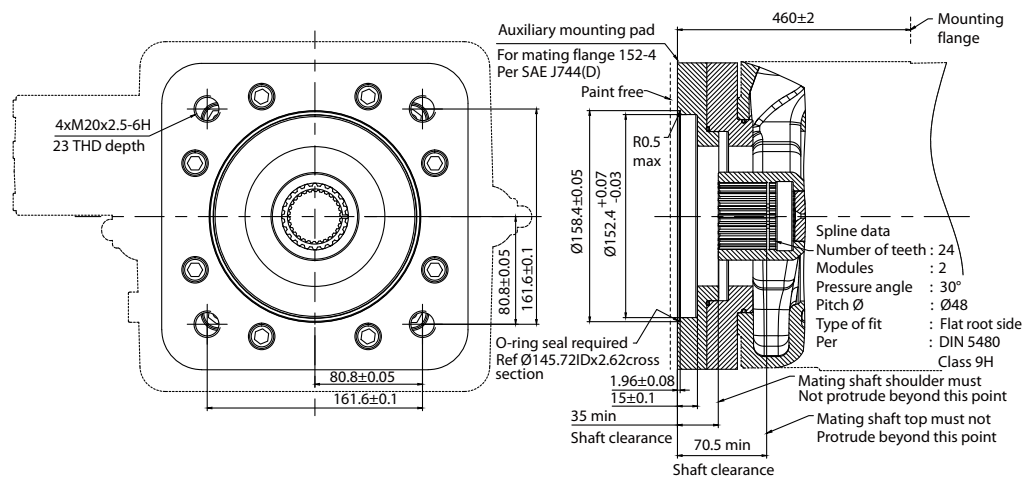

P400416

Specifications

Option	Coupling	Max torque
D5	N50 x 2 x 30 x 24 x 9H	1936 N·m [17135.04 lbf·in]

**Size 260: Option E2 (SAE-E, 24 teeth)**

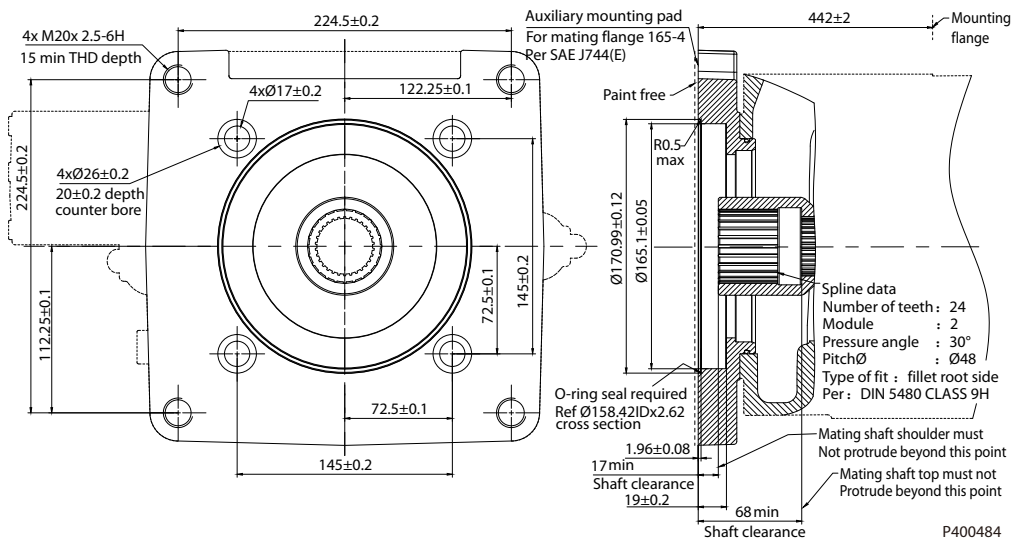

P400484

Specifications

Option	Coupling	Max torque
E2	N50 x 2 x 30 x 24 x 9H	1936 N·m [17135.04 lbf·in]

Installation Drawings

**Size 260: Option E3 (SAE-E, 28 teeth)**

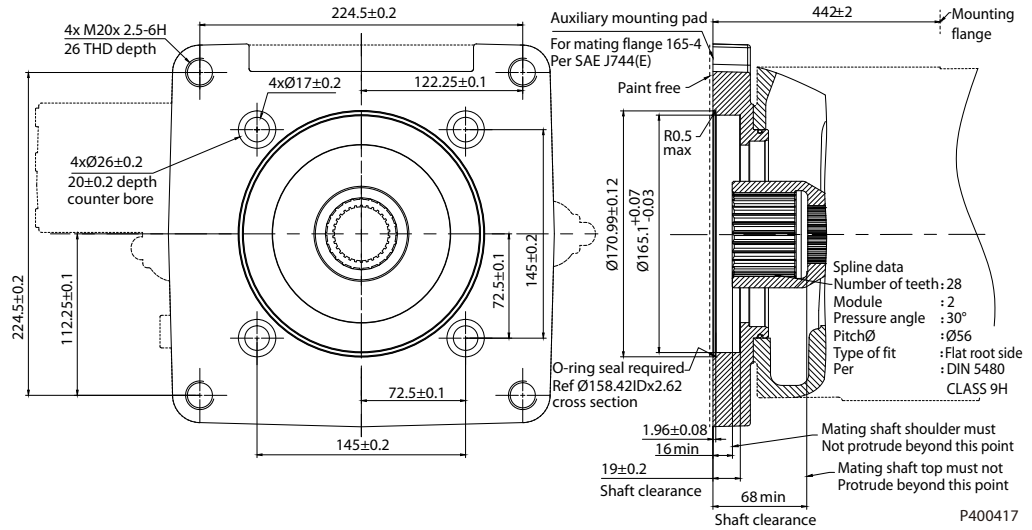

Specifications

Option	Coupling	Max torque
E3	N60 x 2 x 30 x 28 x 9H	1936 N•m [17135.04 lbf•in]

[Before finalizing your design, please request a certified drawing.](#)

**Installation Drawings**

**Inlet pressure gauge port**

An inlet pressure gauge port is offered in certain porting configurations. Pump configurations with this additional port are indicated in the table below.

Displacement	Porting Option		Inlet pressure gauge port
D1P145	CW	w/o impeller	No
		w/ impeller	Yes
	CCW	w/o impeller	Yes
		w/ impeller	Yes
D1P193	CW	w/o impeller	Yes
		w/ impeller	Yes
	CCW	w/ impeller	No
D1P260	CW	w/ impeller	No
	CCW	w/ impeller	Yes

*Inlet pressure gauge port general location*

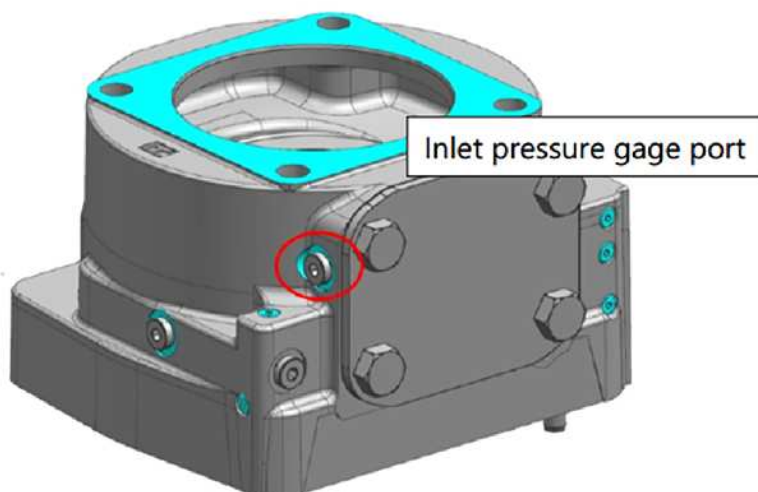

**Installation Drawings**

*D1P 260 CCW + Inlet pressure gauge port*

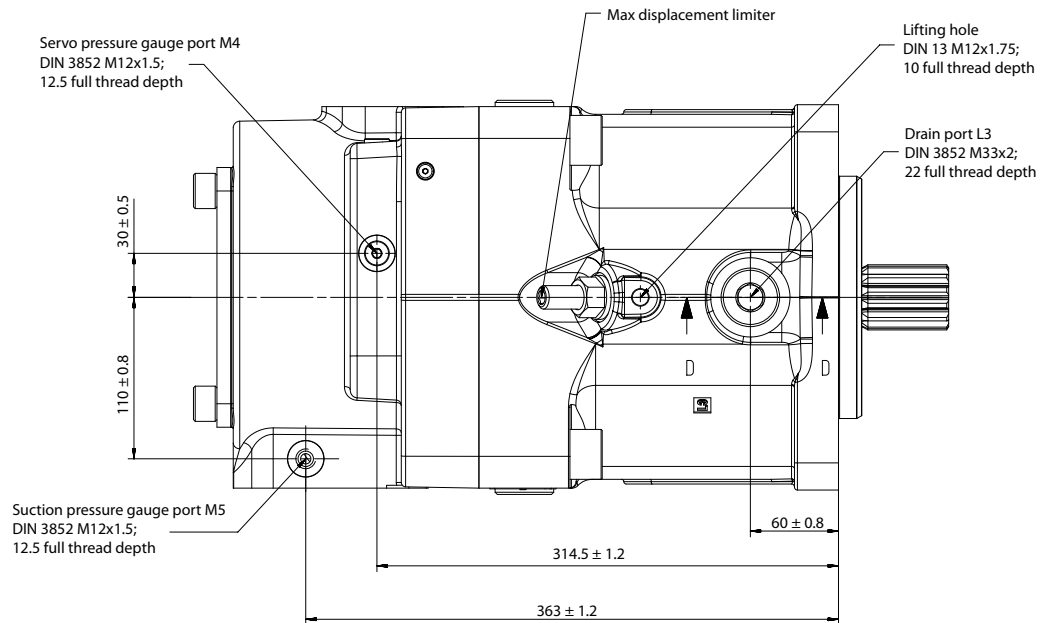

Port	Description	Standard	Size	Max. Pressure (bar [psi])	State
M5	Measurement point, suction pressure	DIN 3852	M12 x 1.5	100 [1450]	X

**Additional Information**
**D1P tandem with Danfoss pumps**

1st Pump			2nd Pump						
D1P (OC)			D1P (OC)	S45 (OC)	S90 (CC)	H1P (CC)	S42 (CC)	S40 (CC)	Gear Pump
Through Drive									
Flange	Coupling	Code	Size (shaft)	Size (shaft)	Size (shaft)	Size (shaft)	Size (shaft)	Size (shaft)	Size (shaft)
82-2 A	5/8 in 9T	A1							4 ~ 45 (SA, SM, SE)
		A3							7 ~ 45 (SH)
101-2 B	7/8 in 13T	B1		25, 30, 38, 45 (C2)		45, 53 (G4)	28, 32, 41, 51 (C)	25, 35, 44, 46 (A)	7 ~ 90 (SA, SL, SH)
127-2&4 C	1 1/4 in 14T	C5		45, 51, 60, 65, 74, 75, 90, 100, 130, 147 (S1)	55, 75, 100 (S1)	60, 68, 69, 78, 89, 100 (G1)			22 ~ 200 (RA, RD, S0)
	1 3/4 in 13T	C9		100, 130, 147 (S4)					
152-4 D	W50	D5	130/145 (T)						
	1 3/4 in 13T	D2			130 (F1)	115, 130, 147, 165 (G3)			
165-4 E	W50	E2	193 (T)						
165-4 E	W60	E3	260 (T)						

**D1P tandem pump torque**

Maximum torque rating and tandem pump torque

D1 Pump Displacement		130/145	193	260
Torque at Vg max and $\Delta p = 350$ bar		724/808 N·m [6407.94/7151.40 lbf·in]	1075 N·m [9514.55 lbf·in]	1448 N·m [12815.88 lbf·in]
Max torque rating of input shaft	T	3100 N·m [27437 lbf·in]	3100 N·m [27437 lbf·in]	5432 N·m [48077 lbf·in]
	S	1528 N·m [13524 lbf·in]	1536 N·m [13595 lbf·in]	1535 N·m [13586 lbf·in]
	A	-	2422 N·m [21437 lbf·in]	3621 N·m [32049 lbf·in]
	P	1411 N·m [12488 lbf·in]	2195 N·m [19427 lbf·in]	2571 N·m [22755 lbf·in]
	K	1787 N·m [15816 lbf·in]	1787 N·m [15816 lbf·in]	1787 N·m [15816 lbf·in]

**Additional Information**
*Maximum torque rating and tandem pump torque (continued)*

D1 Pump Displacement		130/145	193	260
Max torque rating of different aux mounting flange options	A1	205 N·m [1814.40 lbf·in]	205 N·m [1814.40 lbf·in]	205 N·m [1814.40 lbf·in]
	A2	Pending	-	-
	A3	-	619 N·m [5478.61 lbf·in]	619 N·m [5478.61 lbf·in]
	B1	411 N·m [3637.66 lbf·in]	411 N·m [3637.66 lbf·in]	411 N·m [3637.66 lbf·in]
	B2	Pending	Pending	Pending
	BA	411 N·m [3637.66 lbf·in]	411 N·m [3637.66 lbf·in]	411 N·m [3637.66 lbf·in]
	BB	411 N·m [3637.66 lbf·in]	411 N·m [3637.66 lbf·in]	411 N·m [3637.66 lbf·in]
	C5	1164 N·m [10302.27 lbf·in]	1289 N·m [11408.61 lbf·in]	1638 N·m [14497.52 lbf·in]
	C9	-	1790 N·m [15842.83 lbf·in]	1891 N·m [16736.76 lbf·in]
	D2	1130 N·m [10001.35 lbf·in]	1630 N·m [14426.72 lbf·in]	819 N·m [16099.51 lbf·in]
	D5	1164 N·m [10302.27 lbf·in]	1790 N·m [15842.83 lbf·in]	1936 N·m [17135.04 lbf·in]
	E2	-	1790 N·m [15842.83 lbf·in]	1936 N·m [17135.04 lbf·in]
	E3	-	-	1936 N·m [17135.04 lbf·in]

**D1P tightening torque**

The following tightening torques apply:

- Fittings** Observe the manufacturer's instruction regarding the tightening torques of the fittings used.
- Fixing screws** For fixing screws according to DIN 13, we recommend checking the tightening torque individually according to VDI 2230.
- Locking screws** For the metal locking screws supplied with the D1 pump, the required torques are as indicated in the table below:

Thread size	Standard	Required torque	Wrench size
M12 x 1.5	DIN 3852	25 N·m [221.27 lbf·in]	6 mm
M14 x 1.5		34 N·m [300.93 lbf·in]	6 mm
M26 x 1.5		60 N·m [531.05 lbf·in]	12 mm
M33 x 2		225 N·m [1991.42 lbf·in]	17 mm

**Installation Notes**

**D1P below-reservoir (standard)**

*Recommended arrangements : 1 and 2.*

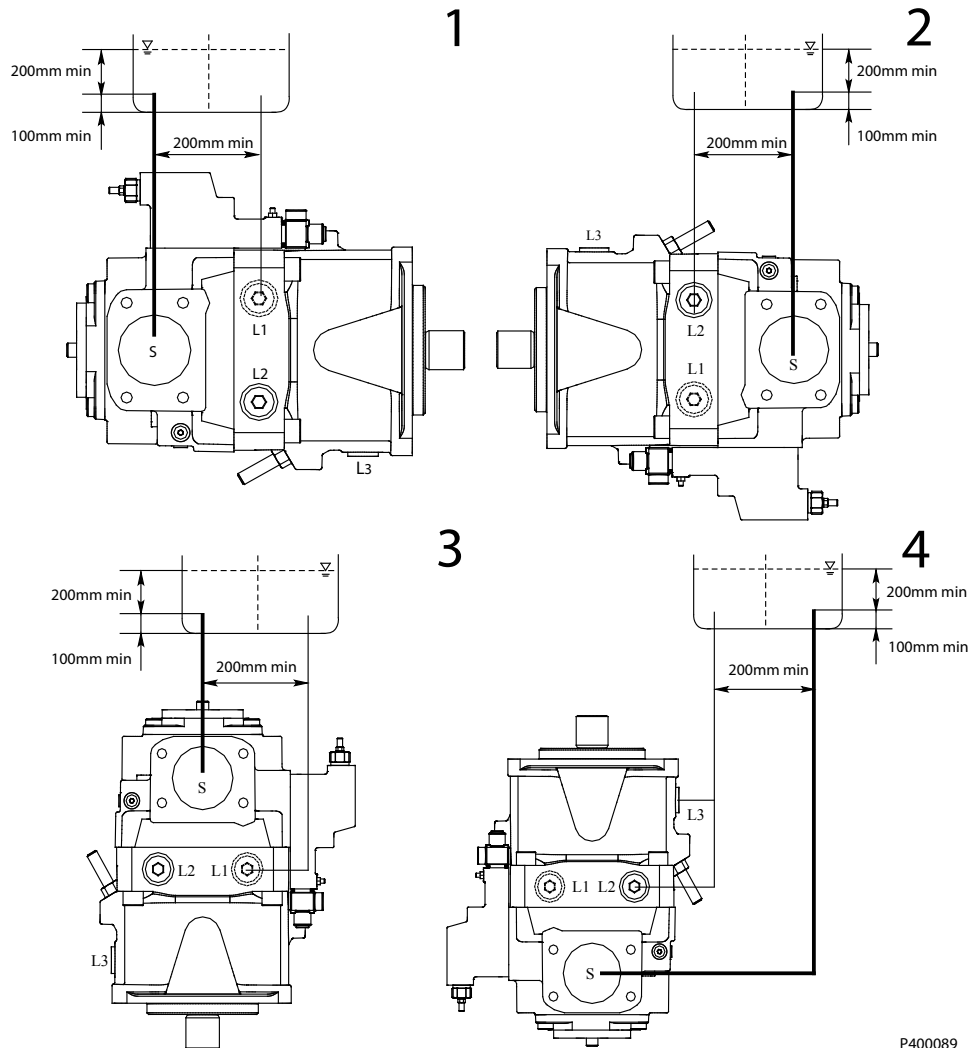

P400089

Fill pump case with clean oil before start

**Suction (absolute) :** P min = 0.6 bar with charge pump (0.8 bar without charge pump), P max = 2 bar. Do not restrict suction line

**Drain (absolute) :** P max = 2 bar. Do not restrict drain line, do not combine drain line

Arrangements	Air Bleeding	Filling
1	L1	S + L1
2	L3	S + L2
3	L1 / L2	S + L1 / L2
4	L3	S + L1 / L2

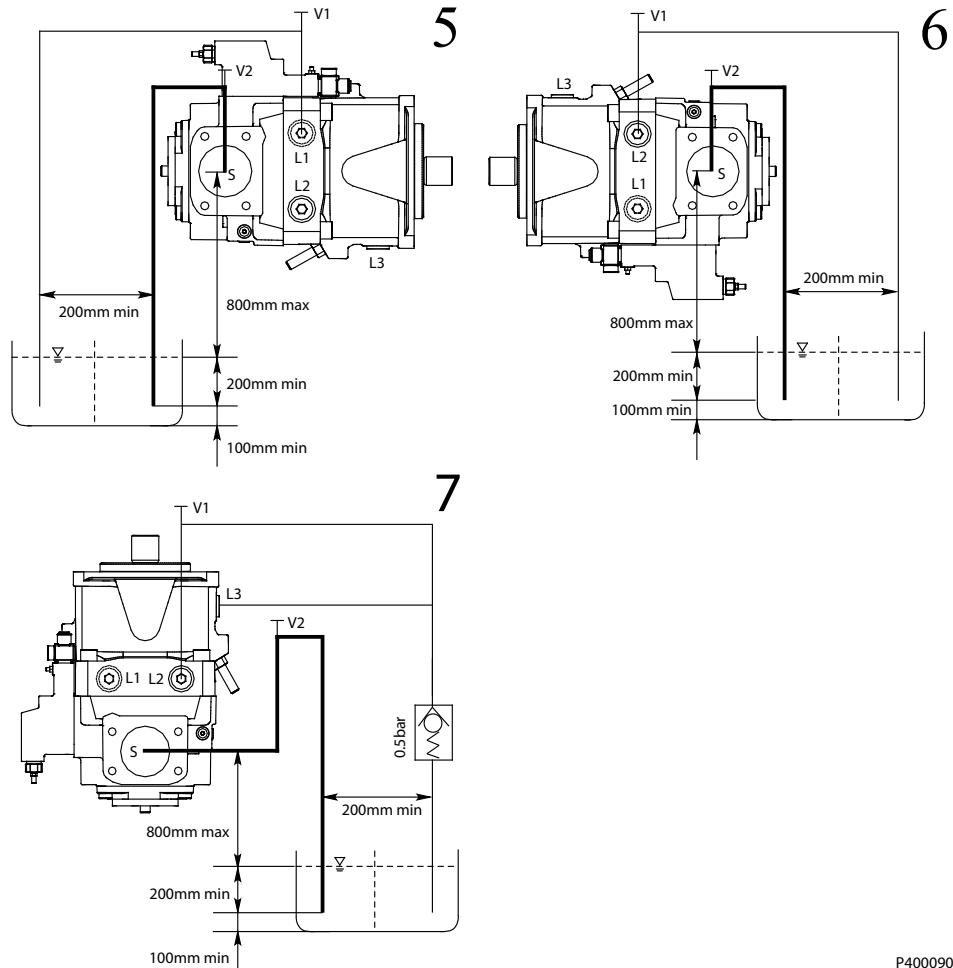
**Installation Notes**
**D1P above-reservoir**

P400090

Fill pump case with clean oil before start

**Suction (absolute) :** P min = 0.6 bar with charge pump (0.8 bar without charge pump), P max = 2 bar. Do not restrict suction line

**Drain (absolute) :** P max = 2 bar. Do not restrict drain line, do not combine drain line

Arrangements	Air Bleeding	Filling
5	V1 + V2	V2 (S) + V1 (L1)
6	L3 + V2	V2 (S) + V1 (L2)
7	V1 + V2	V2 (S) + V1 (L1 / L2)

**Caution! Installation hazards!**

Failure to adhere to the installation notes may result in shortened product life.

The maximum allowable suction height is 0.8m. The allowable suction height is derived from the total pressure loss.

The D1 pump with charge pump is not designed for above-Reservoir installation.

For control options with pressure controllers, proportional displacement control, the minimum displacement setting must be  $V_g \geq 5\% V_{g \max}$ .

Recommendation for arrangement 7 (shaft upwards): A check valve in the case drain line (cracking pressure 0.5 bar) can prevent draining of the case interior.



Installation Notes

D1P reservoir installation

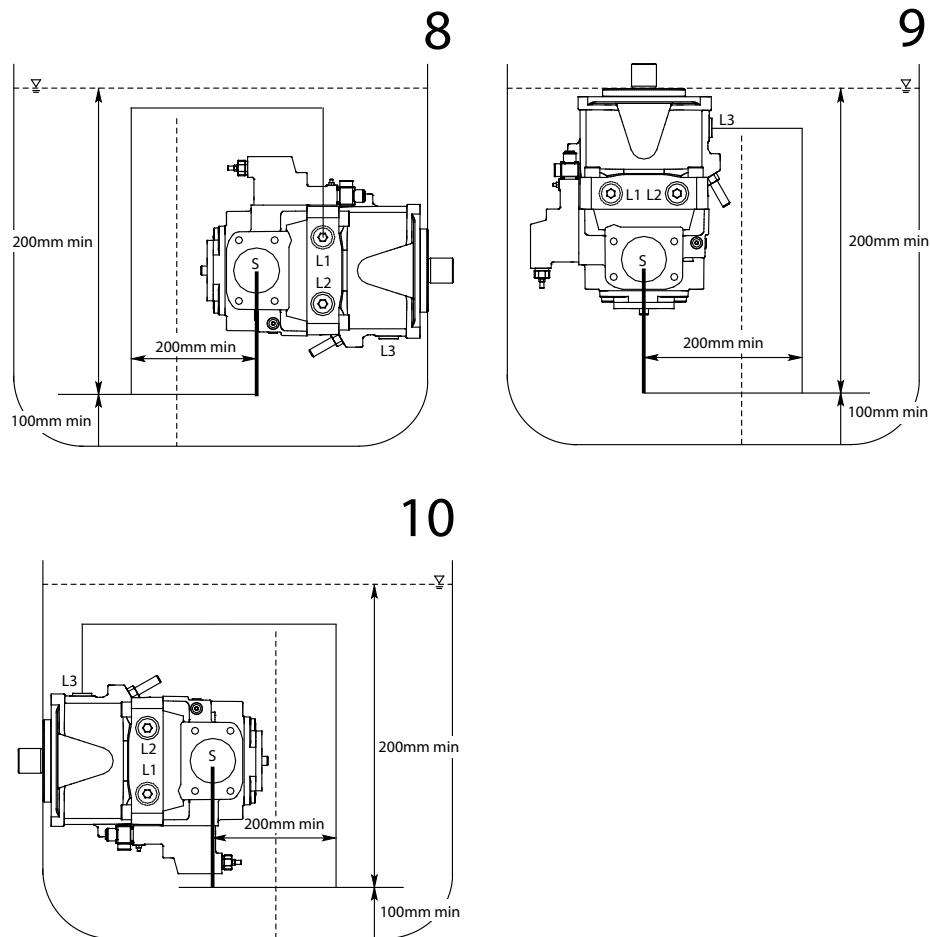

P400091

Fill pump case with clean oil before start

**Suction (absolute) :** P min = 0.6 bar with charge pump (0.8 bar without charge pump), P max = 2 bar. Do not restrict suction line

**Drain (absolute) :** P max = 2 bar. Do not restrict drain line, do not combine drain line

Arrangements	Air Bleeding	Filling
8	L1	Automatically via all open L1, L2, L3 and S ports through position below the hydraulic fluid level.
9	L3	
10	L3	

- It is recommended to fit a pipe to the suction port S and fitting a pipe to case drain port L1, L2 or L3 (See arrangements), the other case drain ports must be plugged in this situation. The pump should be filled before fitting the pipe and filling the tank with hydraulic fluid.
- It is only permissible to install a pump with solenoids (E.g. a pump with electric displacement control) at tank-level, if used hydraulic fluids are based on mineral oil and the oil temperature in the tank does not exceed 80° C.

**Displacement Limiter**

**D1P displacement limiter**

Series D1 pumps feature maximum and minimum displacement limiters, which limit displacement mechanically.

*Maximum Displacement Limiter*

Frame	Setting range	Displacement change per turn
<b>130</b>	72 cm <sup>3</sup> – 130 cm <sup>3</sup>	11 cm <sup>3</sup> /rev
<b>145</b>	72 cm <sup>3</sup> – 145 cm <sup>3</sup>	11 cm <sup>3</sup> /rev
<b>193</b>	0 cm <sup>3</sup> – 193 cm <sup>3</sup>	16 cm <sup>3</sup> /rev
<b>260</b>	56 cm <sup>3</sup> – 260 cm <sup>3</sup>	19 cm <sup>3</sup> /rev

*Minimum Displacement Limiter*

Frame	Setting range	Displacement change per turn
<b>130</b>	0 cm <sup>3</sup> – 124 cm <sup>3</sup>	9 cm <sup>3</sup> /rev
<b>145</b>	0 cm <sup>3</sup> – 124 cm <sup>3</sup>	9 cm <sup>3</sup> /rev
<b>193</b>	0 cm <sup>3</sup> – 193 cm <sup>3</sup>	15 cm <sup>3</sup> /rev
<b>260</b>	0 cm <sup>3</sup> – 260 cm <sup>3</sup>	18 cm <sup>3</sup> /rev

*Displacement Limiter Cross-Section View*

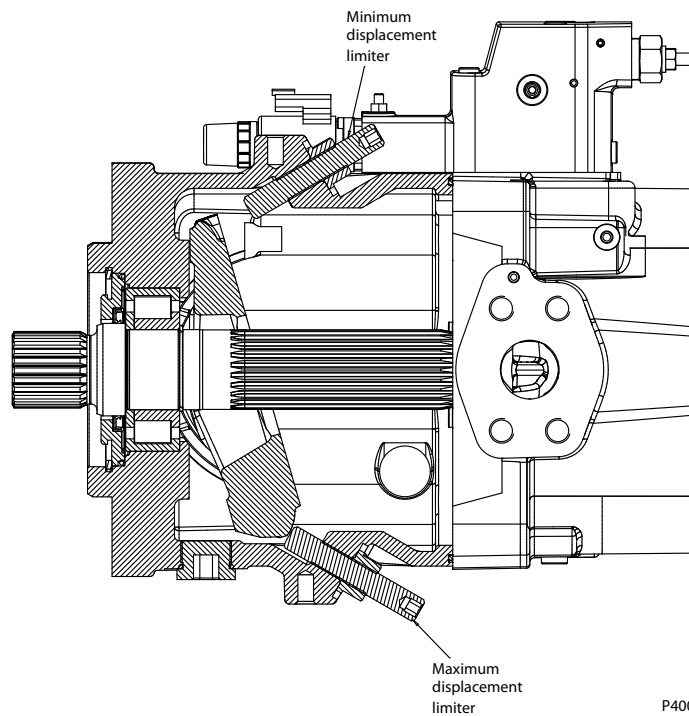

Shandong Topkit Construction Machinery Equipment Co., Ltd., is a high-tech company specialized in the manufacturing and supplying for hydraulic pumps, valves, motors, reducers, gearboxes, etc.

We mainly focuses on hydraulic parts for hydraulic excavators, and the products have been serialized. We dedicated on the following three systems and five series products. We specialized in Positive flow system, negative flow system, load sensing control system;

Five series refer to 6-ton products, 8-ton products, 20-ton products, 40-ton products, concrete series products.

Our featured products 20-ton excavator negative flow pump, positive flow pump, positive flow valve, and rotary motor passed the national appraisal in 2012.

In quality control, we passed the ISO2001:2015 quality management system certification in 2022; and we also passed the ISO14001:2015 environmental management system certification in this year. We always persist in the quality control and try best to enhance quality all the time.

In R&D Field, we have a professional team with more than 10 people, of which more than 90% have accumulated more than ten years of hydraulic product technology, and have become the main force for the company to develop new products.

Now our products has exported to dozens of countries, such as Russia, Middle East countries, Asian and African countries.

We will continue to develop new products in top quality, and sincerely wish establishing business cooperation with more friends. Thanks

**phone:+86 150 539 47199**

**email:george@topkitparts.com**

**web:topkitparts.com**