

# Danfoss 45 Series Open Circuit Axial Piston Pumps Data



For more than 40 years, Danfoss has been developing state-of-the-art components and systems for mobile machinery used in off-highway operations around the world. We have become a preferred supplier by offering the best of what really matters: The hardware inside your vehicle application.

Series 45 pumps are a high efficiency alternative to traditional open circuit pumps. Each frame size is uniquely designed to optimize performance, size, and cost, while matching the demanding requirements of the mobile equipment market.

Series 45 pumps are designed to fit the needs of open circuit systems capable of speeds up to 3600 rpm, maximum pressures up to 400 bar, continuous pressures up to 310 bar [4500 psi]. Series 45 pumps offer a wide variety of control options such as Electronic Torque Limiting (ETL).

Series 45 pumps are PLUS+1<sup>®</sup> compliant. With robust designs and proven reliability in the test lab and the field, Series 45 pumps set the standard for market quality. Danfoss pumps are supported by a global network of authorized service centers.



## Features

### Designed for durability and flexibility

- Heavy-duty tapered roller bearings for long life
- Single piece rigid housing reduces leak paths and noise
- Designed and manufactured to rigorous standards for mobile equipment
- Displacements ranging from 25 to 147 cm<sup>3</sup>/rev [1.53 - 8.97 in<sup>3</sup>/rev]

### Installation and packaging benefits

- Compact design minimizes installation space requirements
- Wide range of mounting flanges, shafts, and porting options for ease of installation
- Robust input shaft bearings to handle large external loads
- Low noise for operator comfort

### Wide range of controls

- Pressure Compensating (PC)
- Load Sensing (LS)
- Remote Pressure Compensation (RP)
- Electric Normally Open On/Off - 12 V / 24 V (NO)
- Electric Normally Closed On/Off - 12 V / 24 V (NC)
- Electric Proportional Pressure Control (EPC)
- Electronic Torque Control (ETL) with angle sensor

### Application benefits

- Optimized design maximizes efficiency and quiet operation
- PLUS+1<sup>®</sup> compliant control options
- Simple design reduces service requirements
- Optimizes machine power usage to maximize productivity

**Specifications**

Pump model		Frame L		Frame K		Frame J		
Maximum displacement	cm <sup>3</sup> [in <sup>3</sup> ]	25 [1.35]	30 [1.83]	38 [2.32]	45 [2.75]	45 [2.75]	51 [3.11]	60 [3.66]
Cont. working pressure	bar [psi]	260 [3770]	210 [3046]	260 [3770]	210 [3046]	310 [4500]	310 [4500]	310 [4500]
Max. working pressure		350 [5075]	300 [4350]	350 [5075]	300 [4350]	400 [5800]	400 [5800]	400 [5800]
Continuous input speed	min <sup>-1</sup> (rpm)	3200	3200	2650	2650	2800	2700	2600
Theoretical flow	l/min [US gal/min]	80 [21.1]	96 [25.4]	100.7 [26.6]	119.2 [31.5]	126 [33.3]	137.7 [36.4]	156 [41.2]
Weight	kg [lb]	Axial 19 [41.9], Radial 24 [52.9]				Axial 23.1 [51.0], Radial 27.3 [60.2]		
Pump model		Frame J (cont.)		Frame F		Frame E		
Maximum displacement	cm <sup>3</sup> [in <sup>3</sup> ]	65 [3.97]	75 [4.58]	74 [4.52]	90 [5.49]	100 [6.1]	130 [7.93]	147 [8.97]
Cont. working pressure	bar [psi]	260 [3770]	260 [3770]	310 [4500]	260 [3770]	310 [4500]	310 [4500]	260 [3771]
Max. working pressure		350 [5075]	350 [5075]	400 [5800]	350 [5075]	400 [5800]	400 [5800]	350 [5075]
Continuous input speed	min <sup>-1</sup> (rpm)	2500	2400	2400	2200	2800	2200	2100
Theoretical flow	l/min [US gal/min]	162 [42.9]	180 [47.5]	177.6 [47.4]	198 [52.8]	245 [64.7]	286 [75.6]	308 [81.4]
Weight	Axial	kg [lb]	23.1 [51.0]		29.5 [65.0]		51.3 [113]	
	Radial		27.3 [60.2]		32.6 [71.9]		54.9 [121]	

**Dimensions**

*Frame L/K Axial (top) and Radial (bottom)*

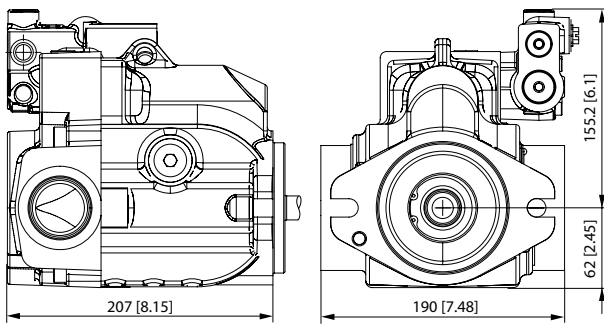
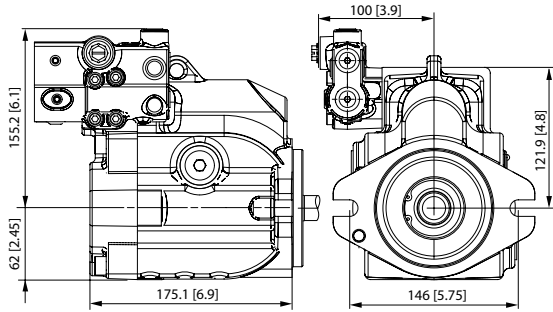

*Frame J Axial (top) and Radial (bottom)*

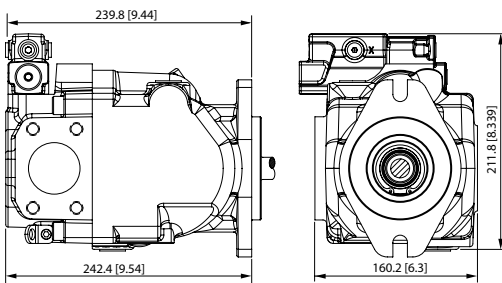
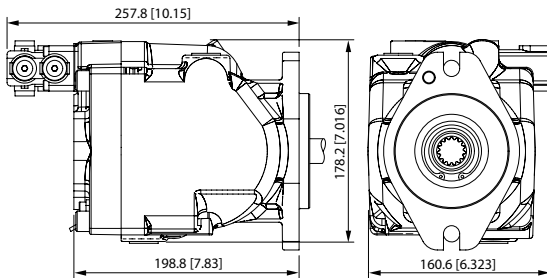

*Frame F Axial (top) and Radial (bottom)*

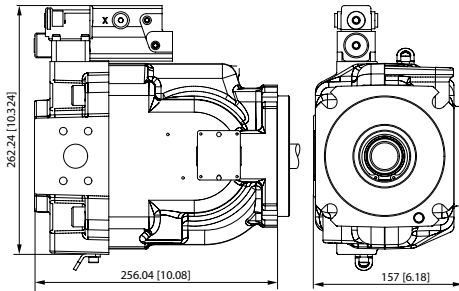
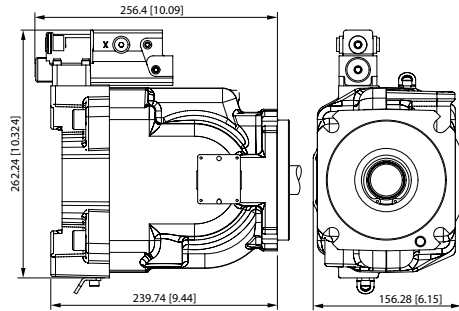

*Frame E Axial (top) and Radial (bottom)*

